



MAIN CATALOG 2023

Experts in energy measurement technology

Janitza[®]





COMPANY PROFILE

PRODUCTS

SERVICES

TECHNICAL APPENDIX

INFORMATION

COMPANY PROFILE

6	Janitza electronics GmbH
10	Industry solutions
12	Energy management – Power quality – Residual current monitoring
14	Measure – Analyze – Control

PRODUCTS

Overviews	18	Selection guide for UMGs
	20	Overview of UMG measurement devices
	24	Communication levels
Front panel meters	28	Universal measurement devices
	34	Energy analyzers
	42	Network analyzers
	80	Power quality analyzer
	88	Power quality analyzer, Class A
DIN rail meters	98	Universal measurement devices
	108	Energy analyzers
	114	Network analyzers
	140	Power quality analyzers
	146	Residual current monitors
	166	MID energy meters
Current transformer	187	Operating current transformers
	227	Residual current transformers
	247	Accessories
Accessories	254	EasyGateway V50
	256	Gateway MBUS-GEM
	257	PowerToStore
	262	Switching power supplies
	264	GPS radio receivers
	266	Fieldbus modules, FBM series
	268	Mounting and installation aids



Measurement data acquisition	276	ProData® – Data logger and Ethernet Modbus Gateway
	282	JPC 100-WEB – Smart Energy Panel
Software	290	GridVis® – Power Grid Monitoring Software & GridVis® Collector
	306	GridVis® Cloud – Energy monitoring portal
	322	Multiprotocol server – OPC UA
	326	Database server – Complete server with GridVis® and database
	332	APPs – Enhancements with know-how
	344	Device homepage – Energy management & PQ analysis online

SERVICES – JANITZA SERVICE

346	Jasic® – Versatile programming options
354	Courses & training
358	Commissioning & Calibration
364	Mobile rental equipment
367	Remote maintenance contracts
369	Other services

TECHNICAL APPENDIX

374	Standards and directives
388	High availability through 3-in-1 monitoring
426	Continuous measurement
431	Formulary
438	Current transformer
449	Communication
460	Prerequisite and confirmation for commissioning (VBI)

INFORMATION

470	Logistics information and Terms and Conditions
------------	--

JANITZA AT EVERY LEVEL

No matter where you are in the world; in which country, in which industry, at work or at home, electrical energy plays an important role in life. But not all electricity is the same. Numerous parameters determine the quality of current and voltage. These affect the smooth operation of equipment and electrical consumers. The question of where the electricity

comes from – whether it was generated renewably, for example – is becoming increasingly relevant in society. Energy is to be conserved, and at the same time demand is increasing. The way electricity is consumed is also changing. All of this is changing the demands made on the supply of energy and making it necessary to take an ever closer look.



Janitza energy measurement technology can be used in all areas. No matter whether in a data center, in industry or in a local distribution substation at the roadside. For every requirement, we offer the right measurement device to monitor power and voltage and record all relevant parameters.

These measured values make it possible to monitor networks, compensate for irregularities and conserve energy. Gradually developing faults can be detected and fires and failures can be prevented. This enables constant improvement of the quality and efficient use of energy.





JANITZA ENERGY MEASUREMENT

A FUTURE WITH TRADITION

For more than 60 years, we have been engaged in development and manufacturing in Lahnau in Hesse, between Wetzlar and Gießen. Our hardware and software products are always one step ahead of their time. We introduce new technologies and combine existing applications to create compelling, intelligent solutions and products.

From Eugen Janitza GmbH, founded in 1961, Janitza electronics GmbH emerged in 1986 as an independent subsidiary under the management of Markus Janitza. Just two years after its founding, Janitza presented the world's first electronic power factor controller with harmonics threshold values and automatic stage disconnection.

Since July 2020, Rudolf Müller has been the second managing director of Janitza electronics GmbH, attending to the company's continuous growth with his expertise. With more than 330 employees and project experience on 6 continents, we are now well positioned to face the new challenges of the market.

Ensuring safe, sustainable and efficient use of electrical energy is our primary goal. We not only want to support our customers and partners in this respect, but also strive to constantly optimize energy efficiency in our own buildings – for the good of the environment.

330

**CURRENT
NUMBER OF EMPLOYEES**

6

CONTINENTS

30 %

**ENERGY EFFICIENCY
SAVINGS**



WORLDWIDE PROJECTS – LOCAL SUPPORT

Janitza implements projects worldwide in the areas of energy management, power quality and residual current monitoring. Being directly accessible to our customers on site is of particular importance to us. We already have our own technical sales offices in six regions and, together with our strong partner network, we are available to customers worldwide.

In addition to sophisticated logistics, Janitza customers benefit globally from comprehensive services such as technical

consulting and the development of customer-specific monitoring solutions. We also support our customers by training their employees, helping to analyze and evaluate measurement data. Our online services make us location-independent.

With experience in project work on all continents, we cover all major market segments, such as industry, building services engineering, energy suppliers and data centers, and are constantly finding new solutions.

60

**COUNTRIES WE
SUPPLY**

8

**COUNTRY
REPRESENTATIVES**

91

**INTERNATIONAL
PARTNERS**

INDUSTRY SOLUTIONS

INDUSTRY

The world over, industry finds itself confronted with high demands. High availability is an important topic in many areas and Janitza provides support in detecting and eliminating faults at an early stage. Janitza energy measurement technology helps to comply with legal requirements dealing with energy efficiency and management, strengthens fire protection and, in combination with GridVis®, simplifies documentation.

DATA CENTERS

With increasing digitization, the challenges for data centers are growing. Nothing must fail, constant availability and safety are extremely important, while at the same time the demand for energy efficiency is constantly on the rise. Janitza gives you a comprehensive overview at all levels, identifies savings potentials and ensures high availability by detecting disturbance variables in current and voltage at an early stage.



ENERGY SUPPLIERS

Changing and unreliable load profiles, distributed generators, the growing number of electric vehicles and increasing digitization have intensified the demands on energy suppliers. Janitza energy measurement technology collects urgently needed data, makes current and voltage variables transparent and is easy to integrate. Our compensation solutions help to quickly eliminate reactive power and grid disturbances to provide the best possible protection for buildings and equipment.



BUILDING SERVICES ENGINEERING

High demands on building services engineering and increasing automation require a precise overview of the current state of buildings and consumption. Thanks to a large portfolio, Janitza meters can be used for everything from energy monitoring in air handling units to consumption metering in offices and commercial premises. Various interfaces allow integration into different systems as well as into the BMS.



COMPREHENSIVE MEASUREMENT SOLUTIONS

Regardless of the industry, the requirements for energy efficiency, sustainability, high availability and safety are increasing. To meet all these requirements necessitates maintaining a holistic perspective on energy. Janitza goes far beyond pure energy measurement and combines the aspects of energy management, power quality and residual current monitoring into a holistic measurement solution in a single system environment.

Capture exactly the parameters you need without installing a lot of technology. No matter whether dealing specifically with residual current or energy, for example, or whether you want to record all parameters, our range includes specialized measurement devices as well as "all-rounders" for the optimal fulfillment of your measurement task.

Our 3-in-1 concept relies on the building blocks of energy management, power quality and residual current monitoring. We offer you the appropriate measurement technology, support you in the analysis and create individual solutions for the protection of your systems and equipment.



ENERGY MANAGEMENT

Energy management plays an important role in all industries. The aim is to increase energy efficiency, help companies on their way to CO₂ neutrality, and to reduce consumption and costs. With the right energy management, these goals can be achieved and requirements, e.g. of standards, can be met. The measurements this entails increase transparency and also reveal irregularities in consumption.

POWER QUALITY

Insufficient power quality can lead to operational disturbances, outages and premature shutdown of systems. By recording and evaluating power quality parameters, impending problems are detected at an early stage. This enables you to react quickly and initiate measures to prevent failures and wear and to ensure the high availability of machinery and systems.

RESIDUAL CURRENT MONITORING

Residual current monitoring (RCM) is playing an increasingly important role for applications requiring highly available power supplies. With continuous residual current monitoring, you have your low-voltage network under control. Dangerous residual currents that can lead to system malfunctions or increase the risk of fire are detected at an early stage so that a production stoppage can be avoided.

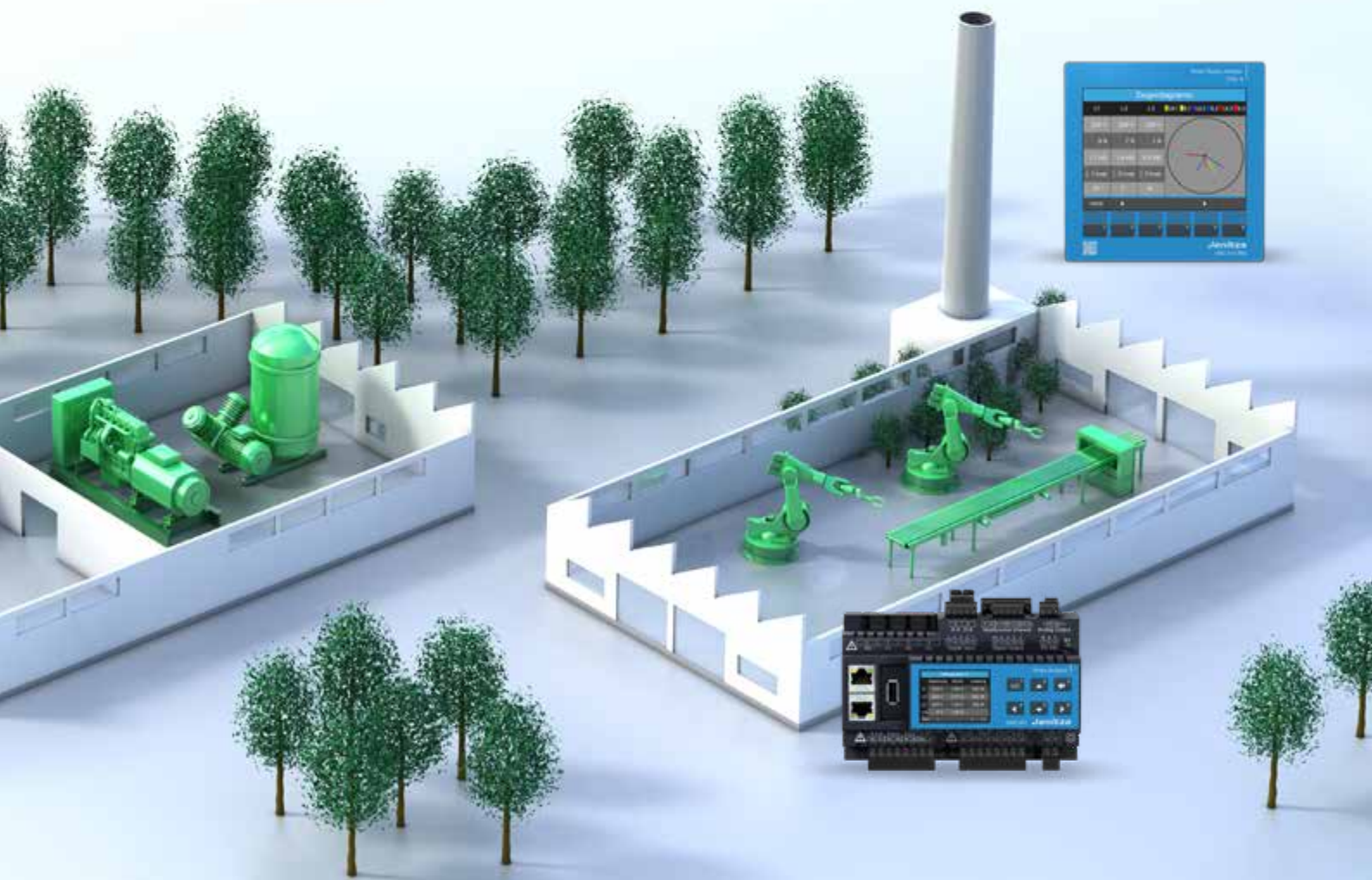

MEASURE – ANALYZE – CONTROL

MEASURE

A high-quality energy measurement device is the basic prerequisite for continuously recording energy data, analyzing energy consumption, and protecting people, machines, and systems from failure. Janitza energy measurement devices are ideally suited for measurements from the infeed to sub distribution, whether on the DIN rail or in the front panel installation. We offer our customers much more than measurement devices to ensure the transparency of energy data and to solve the challenges of modern energy measurement

technology. As a strong partner, we accompany you: from the acquisition of measurement data and its analysis to the active protection of people, equipment, and systems. We help with finding the best solution for individual requirements as early as the selection and project planning stage. Our service offer includes the installation, configuration, parameterization, and maintenance of the purchased measurement devices, as well as training courses so you can use your Janitza measurement device optimally in practice.

**"IF YOU CAN NOT MEASURE IT,
YOU CAN NOT IMPROVE IT."**

William Thomson (1st Baron Kelvin, a.k.a. Lord Kelvin)



ANALYZE

In the GridVis® Cloud energy monitoring portal, measured values for energy, water, and gas can be displayed easily and clearly. Important information, such as the CO₂ balance, can be automatically generated and displayed via stored contracts. The GridVis® power grid monitoring software is perfectly suited for visualizing and analyzing extensive energy parameters and goes far beyond displaying the measured values. Numerous visualization options are available. Functions such as the event and transient browser or the creation of KPIs create additional transparency. Integrated, ready-made reports enable evaluations in relation to selected standards, such as EN 50160.

CONTROL

If you know your energy flows then you can control them. And those who control the energy flows have a firm grip on consumption and thus on energy costs and efficiency. With the Procont® system from Janitza, active load management can be operated and energy flows can be controlled in a targeted manner. From traditional applications, such as the avoidance of peak loads, to the control of battery storage systems and PV installations, to the optimized use of charging stations in e-mobility. Janitza not only takes care of the hardware, but also supports you in planning and implementation as a reliable partner.



Janitza Power Analyser

U _A	228 V	3.91 A	828 W	302 var	0.77
U _B	228 V	2.81 A	371 W	402 var	0.98
U _C	228 V	2.81 A	371 W	402 var	0.98
U _N	1.14 V	1.85 A	8.08 W	1.08 var	0.99
S _{1,2}	50.0 Hz	1.05 A	2.80 kW	4.41 kvar	0.88

Ausgang Eingang

Janitza

U_A 228 V

U_B 228 V

U_C 228 V

U_N 1.14 V

S_{1,2} 50.0 Hz

Ausgang Eingang

Janitza UMG 500-4100-3060

	Spannung	Strom	Wirkleistung	Blindleistung	PF1
U _A	228 V	11.33 A	1.81 kW	4.72 kvar	0.88
U _B	228 V	3.92 A	612 W	402 var	0.94
U _C	228 V	2.81 A	371 W	302 var	0.77
U _N	1.14 V	1.85 A	8.08 W	1.08 kvar	0.99
S _{1,2}	50.0 Hz	1.05 A	2.80 kW	4.41 kvar	0.88

Ausgang Eingang

Janitza UMG 500-4100-3060

Janitza UMG 500-4100-3060

	Spannung	Strom	Wirkleistung	Blindleistung	PF1
U _A	228 V	11.33 A	1.81 kW	4.72 kvar	0.88
U _B	228 V	3.92 A	612 W	402 var	0.94
U _C	228 V	2.81 A	371 W	302 var	0.77
U _N	1.14 V	1.85 A	8.08 W	1.08 kvar	0.99
S _{1,2}	50.0 Hz	1.05 A	2.80 kW	4.41 kvar	0.88

Ausgang Eingang

Janitza UMG 500-4100-3060

PRODUCTS

Overviews	18	Selection guide for UMGs
	20	Overview of UMG measurement devices
	24	Communication levels
Front panel installation measurement devices	28	Universal measurement devices
	34	Energy analyzers
	62	Network analyzers
	80	Power quality analyzers
DIN rail measurement devices	88	Power quality analyzer, Class A
	98	Universal measurement devices
	108	Energy analyzers
	114	Network analyzers
	140	Power quality analyzers
	146	Residual current monitors
	166	MID energy meters
Current transformer	187	Operating current transformers
	227	Residual current transformers
	247	Accessories
Accessories	254	EasyGateway V50
	256	Gateway MBUS-GEM
	257	PowerToStore
	258	D-Sub bus connector
	259	RS-485 repeater and converter cable
	262	Switching power supplies
	264	GPS radio receivers
	266	Fieldbus modules, FBM series
268	Mounting and installation aids	

DIN RAIL MEASUREMENT DEVICES

Universal measurement devices



UMG 806

- 31st harmonic
- Modular expandability
- Residual current detection
- Optional Ethernet
- Display & 2-button operation
- Class 0.5S

Energy analyzers



UMG 103-CBM

- 40th harmonic
- Communication settings directly on the device
- Compact – 4 TE
- Comparator
- Continuous measurement
- Modbus interface
- Class 0.5S

Network analyzers



UMG 801

- 127th harmonic
- Class S according to IEC 61000-4-30
- Modular expandability (92 channels)
- Multifunction channels: Residual current, temperature, operating current
- Events and transients
- High dielectric strength, 1000 V CAT III
- Class 0.2S



UMG 604-PRO

- 40th harmonic
- Device homepage
- Events and transients
- Programming options (Jasic & Apps)
- Power quality analysis onboard
- 300 V CAT III
- Class 0.5S

Power quality analyzers



UMG 605-PRO

- 63rd harmonic
- Device homepage
- Flicker measurement
- Events and transients
- Programming options (Jasic & Apps)
- Power quality analysis onboard
- EN 50160 / 61000-2-4
- Class S according to IEC 61000-4-30

Residual current monitors



UMG 20CM

- 63rd harmonic
- Modular expandability
- Optional operating/residual current measurement
- 4 voltage measurement channels
- 20 measuring channels
- 20 LEDs for warning and alarm alerts



RCM 202-AB

- Standards-compliant to DIN EN 62020
- Residual current analysis, type B
- Residual current detection, type B+
- Modbus interface
- LCD display

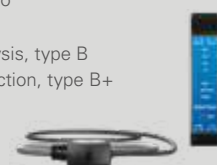

RCM 201-ROGO

- Measurement with Rogowski coil
- Modbus interface
- Various measuring ranges configurable

FRONT PANEL INSTALLATION MEASUREMENT DEVICES



- 15th harmonic
- Cost effective
- 2-button operation
- Modbus interface
- Class 0.5S

UMG 96-S2



- 40th harmonic
- Different interface variants
- 2-button operation
- Comparator
- Continuous measurement
- Modbus interface
- Class 0.5S

UMG 96RM series



- 40th harmonic
- Modular expandability
- Residual current detection
- MID certification
- Meter reading cycle to PTB-A 50.7
- 600 V CAT III
- Ethernet interface
- Class 0.2S

UMG 96-PA series



- 40th harmonic
- Residual current detection
- Device homepage
- Events (200 ms)
- 300 V CAT III
- Ethernet interface
- Class 0.5S

UMG 96RM-E



- 65th harmonic
- Class S according to IEC 61000-4-30
- Modular expandability
- Residual current detection
- Color graphic display & 6-button operation
- 600 V CAT III
- Ethernet interface
- Events (20 ms)
- Class 0.2S

UMG 96-PQ-L



- 63rd harmonic
- Residual current detection
- Events and transients
- Programming options (Jasic & Apps)
- Power quality analysis onboard

UMG 509-PRO

Power quality analyzer, Class A



- 63rd harmonic
- Class A according to IEC 61000-4-30
- Residual current detection
- Flicker measurement
- Events and transients
- Programming options (Jasic & Apps)
- Power quality analysis onboard
- EN 50160 / 61000-2-4

UMG 512-PRO



&



Type	UMG 103-CBM (UL certified)	UMG 20CM	Module 20CM-CT6	UMG 604-PRO (UL certified)	
				E	EP
Item number	5228001	1401625	1401626	5216202	5216201
Use in three-phase 4-conductor systems with grounded neutral conductor up to a maximum of	277 / 480 V AC	230 / 400 V AC	Only current measurement	277 / 480 V AC	
Use in three-phase 3-conductor systems ungrounded up to a maximum of	-	-	-	480 V AC	
Supply voltage	-	90 – 276 V AC; 90 – 276 V DC	-	95 – 240 V AC; 135 – 340 V DC ¹¹	
Three-conductor / four-conductor (L-N, L-L)	- / •	• / •	- / •	• / •	
Quadrants	4	4	4	4	
Sampling rate 50/60 Hz, measuring points per second	5.4 kHz	20 kHz	60 kHz	20 kHz	
National certification according to PTB-A 50.7	-	-	-	-	
Effective value from periods (50/60 Hz)	10 / 12	10 / 12	10 / 12	10 / 12	
Residual current inputs	-	20 ¹¹	6 ¹¹	-	
Current measuring channels	3	20 ¹¹	6–96 (max. 16 modules) ¹¹	4	
Thermistor input	-	-	-	1	
Harmonics V / A	1. – 40.	1. – 63.	1. – 63.	1. – 40.	
Distortion factor THD-U / THD-I in %	•	•	only THD-I	•	
Unbalance	-	-	-	•	
Short-term flicker / long-term flicker	-	-	-	-	
Transients	-	-	-	> 50 µs	
Short-term interruptions	-	-	-	•	
Accuracy V; A	0.2%; 0.5%	1%; 1%	- ; 0.5%	0.2%; 0.25%	
Class A per EN 61000-4-30	-	-	-	-	
Active energy class	0.5S (.../5 A)	1	2	0.5S (.../5 A)	
Digital inputs	-	-	-	2	
Digital / pulse output	-	2	-	2	
Analogue output	-	-	-	-	
Memory min. / max. values	•	•	•	•	
Memory size / recording time (factory setting)	4 MB / approx. 3 months	768 KB / approx. 1 month	only via UMG 20CM	128 MB / approx. 4797 months	
Clock	•	•	only via UMG 20CM	•	
Integrated logic	Comparator	Current threshold values per channel	Current threshold values per channel	Jasic® (7 Prg.)	
Websserver / e-mail	-	-	-	• / •	
APPs: Measured value monitor, EN 50160 & IEC 61000-2-4 Watchdog	-	-	-	•	
Fault recorder function	-	-	-	•	
Peak load optimisation	-	-	-	• ²	
Software for energy management and network analysis	GridVis®-Essential	GridVis®-Essential	GridVis®-Essential	GridVis®-Essential	
GridVis® Items	1	1	1	1	
Interfaces					
RS232	-	-	-	•	
RS485	•	•	only via UMG 20CM	•	
USB	-	-	-	-	
D-Sup-9-connector (Profibus)	-	-	-	-	•
M-Bus	-	-	-	-	
Ethernet	-	-	-	•	
Protocols					
Modbus RTU	•	•	only via UMG 20CM	•	
Modbus gateway	-	-	-	•	
Profibus DP V0	-	-	-	-	•
Modbus TCP/IP, Modbus RTU over Ethernet	-	-	-	•	
SNMP	-	-	-	•	
OPC UA	-	-	-	-	
BACnet IP	-	-	-	• ²	
Profinet	-	-	-	-	



	UMG 605-PRO (UL certified)	UMG 801 (UL certified)	Module 800-CT8-A (UL certified)	Module 800-DI14 (UL certified)	UMG 806	UMG 806 modules		
						EC1	ED1	EI1
	5216227	5231003	5231230	5231214	14.02.025	14.02.016	14.02.019	14.02.020
	277 / 480 V AC	347 / 600 V AC (UL) 480 / 830 V AC (IEC)	Only current measurement	Only digital inputs	230 / 400 V AC			
	480 V AC	690 V AC			400 V AC			
	95 – 240 V AC; 135 – 340 V DC ^{*1}	24 V DC, PELV	via basic device	via basic device	80 – 270 V AC; 80 – 270 V DC			
	• / •	• / •			• / •			
	4	4	4		4			
	20 kHz	51.2 kHz (V) / 25.6 kHz (A)	8.33 kHz		8 kHz			
	-	-	-		-			
	10 / 12	10 / 12	10 / 12		10 / 12			
	-	4 ^{*4}			1			
	4	8	8-80		4			4 ^{*12}
	1	4 ^{*4}			1			
	1. – 63.	1. – 127. / 1. – 63.	1., 3., 5. ... 15. only THD-I		1. – 31.			
	•	•			•			
	•	•			•			
	•	•			-			
	> 50 µs	•			-			
	•	•			-			
	0.2%; 0.25% Class S	0.2%; 0.2%	0.5%		0.2%; 0.2%			
	0.5S (.../5 A)	0.2S (.../5 A)	0.5S (.../5 A)		0.5S (.../5 A)			
	2	4		14	-		4	
	2	4			1		2	2
	-	1			-			
	•	•	*9	*9	•			
	128 MB / approx. 2.37 months	4 GB / no factory setting			4 MB			
	•	•	*9	*9	•	•		
	Jasic® (7 Prg.)	-			-			
	• / •	-			-	• / -		
	•	-			-			
	•	-			-			
	• ^{*2}	-			-			
	GridVis®-Essential	GridVis®-Essential	GridVis®-Essential	GridVis®-Essential	GridVis®-Essential	GridVis®-Essential		
	1	1	1	1	1	0	0	0
	•	-			-			
	•	•	*9	*9	•			
	-	•			-			
	•	-			-			
	•	-			-			
	•	2	*9	*9	-	•		
	•	•	*9	*9	•			
	•	• ^{*10}			-	•		
	•	-			-			
	•	Modbus TCP/IP	*9	*9	-	•		
	•	-			-	•		
	-	•	*9	*9	-			
	• ^{*2}	-			-			
	-	-			-			

- : included
 - : not included
 - *1 Other voltages are also optionally available
 - *2 Option
 - *3 Combination possibilities for the inputs and outputs:
a) 5 Digital outputs
b) 2 digital outputs and 3 digital inputs
 - *4 Combined function:
optionally analog / thermistor / residual current input
 - *5 2 pulse outputs
 - *6 SNMP only for internal Profinet communication
 - *7 With module + 1 current measuring channel
 - *8 MID-certified
 - *9 On the basic device
 - *10 For polling the slave device
 - *11 Combined function:
optionally operating and residual current
 - *12 These are 4...20 mA signal inputs
 - *13 289 / 500 V AC with MID+ models
 - *14 Applies to item no. 5236021 and 5236025
 - *15 Partition A: approx. 106 months, partition B: approx. 26 months
 - *16 Approx. 2 months
- Comment: For detailed technical information, please refer to the respective operating instructions and the Modbus address lists.



&



Type	UMG 96-PA (UL certified)		UMG 96-PQ-L (UL certified)				UMG 96-PA & 96-PQ-L module (UL certified)
	96-PA	96-PA-MID+					RCM-EL
Item number	5232001 ¹¹	5232004 ⁸	5236001 ¹¹	5236021 ¹¹	5236005	5236025	5232010
Use in three-phase 4-conductor systems with grounded neutral conductor up to a maximum of	347 / 600 V AC (UL) ¹³ 417 / 720 V AC (IEC) ¹³		347 / 600 V AC (UL) 417 / 720 V AC (IEC)				
Use in three-phase 3-conductor systems ungrounded up to a maximum of	-		-		600 V AC		
Supply voltage	90 – 277 V AC; 90 – 250 V DC ¹¹		90 – 277 V AC; 90 – 250 V DC ¹¹				
Three-conductor / four-conductor (L-N, L-L)	•/•		•/•				
Quadrants	4		4				
Sampling rate 50/60 Hz, measuring points per second	8.13 kHz		13.67 kHz		13.97 kHz		
National certification according to PTB-A 50.7	-		-				
Effective value from periods (50/60 Hz)	10 / 12		10 / 12				
Residual current inputs	-		-				2
Current measuring channels	3 ⁷		3 ⁷				1
Thermistor input	-		-				1
Harmonics V / A	1. – 40.		1. – 65.				
Distortion factor THD-U / THD-I in %	•		•				
Unbalance	-		-				
Short-term flicker / long-term flicker	-		• ¹⁴				
Transients	-		-				
Short-term interruptions	-		•				
Accuracy V; A	0.2%; 0.2%		0.2%; 0.2%				
Class A per EN 61000-4-30	-		Class S ¹⁴				
Active energy class	0.2S (.../5 A)		0.2S (.../5 A)				
Digital inputs	3		3				
Digital / pulse output	3		3				
Analogue output	1		1				
Memory min. / max. values	•		•				
Memory size / recording time (factory setting)	8 MB / approx. 3 months (MID+ load profile: approx. 24 months)		64 MB / partition A: approx. 45 months, partition B: approx. 20 months				
Clock	•		•				
Integrated logic	Comparator		Comparator				
Webserver / e-mail	-		-				
APPs: Measured value monitor, EN 50160 & IEC 61000-2-4 Watchdog	-		-				
Fault recorder function	-		-				
Peak load optimisation	-		-				
Software for energy management and network analysis	GridVis®-Essential		GridVis®-Essential				GridVis®-Essential
GridVis® Items	1		1				1
Interfaces							
RS232	-		-				
RS485	•		•				
USB	-		-				
D-Sup-9-connector (Profibus)	-		-				
M-Bus	-		-				
Ethernet	-		-				•
Protocols							
Modbus RTU	•		•				
Modbus gateway	-		-				•
Profibus DP V0	-		-				
Modbus TCP/IP, Modbus RTU over Ethernet	-		-				•
SNMP	-		-				
OPC UA	-		-				
BACnet IP	-		-				
Profinet	-		-				



UMG 96-S2



UMG 96RM
(UL certified)



UMG 509-PRO
(UL certified)



UMG 512-PRO
(UL certified)

	P M E CBM PN							
5234002	5222061	5222064	5222069	5222062	5222066	5222090	5226001	5217011
230 / 400 V AC	277 / 480 V AC						347 / 600 V AC (UL) 417 / 720 V AC (IEC)	347 / 600 V AC (UL) 417 / 720 V AC (IEC)
-	480 V AC						600 V AC	600 V AC
90 – 265 V AC; 90 – 250 V DC	90 – 277 V AC; 90 – 250 V DC ¹¹						95 – 240 V AC; 80 – 300 V DC ¹¹	95 – 240 V AC; 80 – 300 V DC ¹¹
- / •	• / •						• / •	• / •
4	4						4	4
8 kHz	21.33/25.6 kHz						20 kHz	25.6 kHz
-	-						-	-
16 / 16	10 / 12						10 / 12	10 / 12
-	-	-	-	2	-	2	2	
3	3	4	3	4	4	4	4	
-	-	-	-	2 ¹⁴	-	2 ¹⁴	1	
1. – 15.	1. – 40.						1. – 63.	1. – 63.
•	•						•	•
-	-						-	-
-	-						-	-
-	-						> 50 µs	> 39 µs
-	-						•	•
0.2%; 0.2%	0.2%; 0.2%						0.1%; 0.2%	0.1%; 0.1%
-	-						Class S	Class A
0.5S (.../5 A)	0.5S (.../5 A)						0.2S (.../5 A)	0.2S (.../5 A)
-	-	4	-	(3) ¹³	4	(3) ¹³	2	
1	2	6	2	(5) ¹³	6	(5) ^{13/15}	2	
-	-	-	-	-	-	-	-	
•	•						•	•
-	-	256 MB ¹⁶	-	256 MB ¹⁵	256 MB ¹⁶	-	256 MB / approx. 95.95 months	
-	Comparator						Jasic® (7 Prg.)	Jasic® (7 Prg.)
-	-	-	-	• / •	-	• / -	• / •	
-	-						•	•
-	-						•	•
-	-						-	-
GridVis®-Essential	GridVis®-Essential						GridVis®-Essential	GridVis®-Essential
1	1	1	1	1	1	1	1	
-	-						-	-
•	•	•	-	•	•	•	•	
-	-	•	-	-	•	-	-	
-	-	•	-	-	-	-	•	
-	-	-	•	-	-	-	-	
-	-	-	-	•	-	2	•	
•	•	•	-	•	•	•	•	
-	-	-	-	-	-	-	•	
-	-	•	-	-	-	-	•	
-	-	-	-	•	-	•	•	
-	-	-	-	•	-	•	•	
-	-	-	-	•	-	•	•	
-	-	-	-	•	-	•	•	
-	-	-	-	•	-	•	•	
-	-	-	-	•	-	•	•	
-	-	-	-	•	-	•	•	
-	-	-	-	• ²	-	-	• ²	
-	-	-	-	-	-	•	-	

- : included
 - : not included
 - *1 Other voltages are also optionally available
 - *2 Option
 - *3 Combination possibilities for the inputs and outputs:
a) 5 Digital outputs
b) 2 digital outputs and 3 digital inputs
 - *4 Combined function:
optionally analog / thermistor / residual current input
 - *5 2 pulse outputs
 - *6 SNMP only for internal Profinet communication
 - *7 With module + 1 current measuring channel
 - *8 MID-certified
 - *9 On the basic device
 - *10 For polling the slave device
 - *11 Combined function:
optionally operating and residual current
 - *12 These are 4...20 mA signal inputs
 - *13 289 / 500 V AC with MID+ models
 - *14 Applies to item no. 5236021 and 5236025
 - *15 Partition A: approx. 106 months, partition B: approx. 26 months
 - *16 Approx. 2 months
- Comment: For detailed technical information, please refer to the respective operating instructions and the Modbus address lists.

COMMUNICATION LEVELS

Ethernet level (TCP/IP)

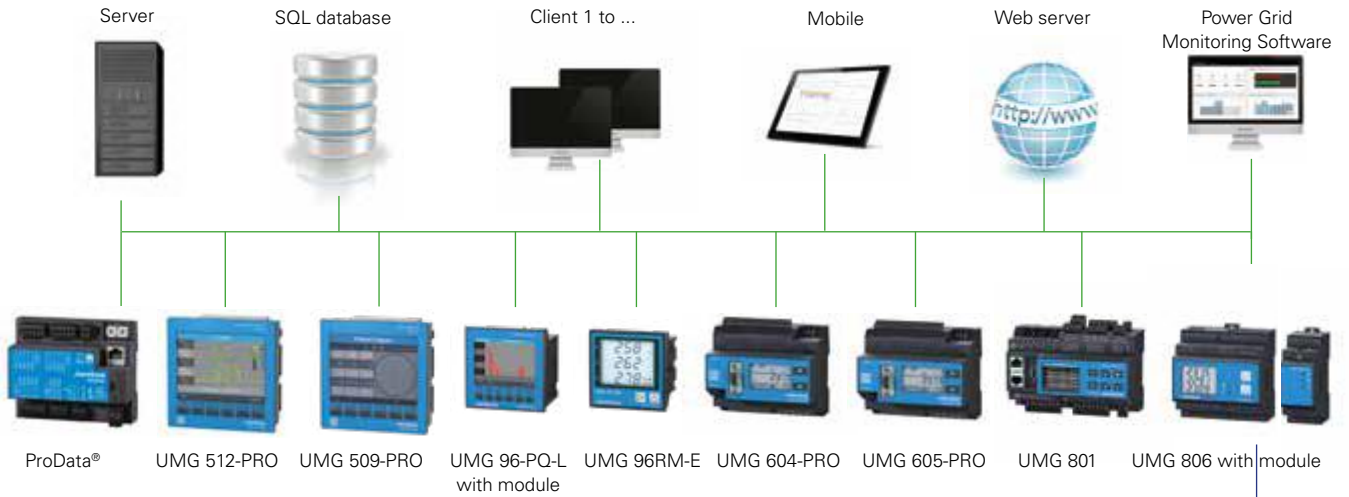

Fieldbus level (e.g. Modbus RTU)

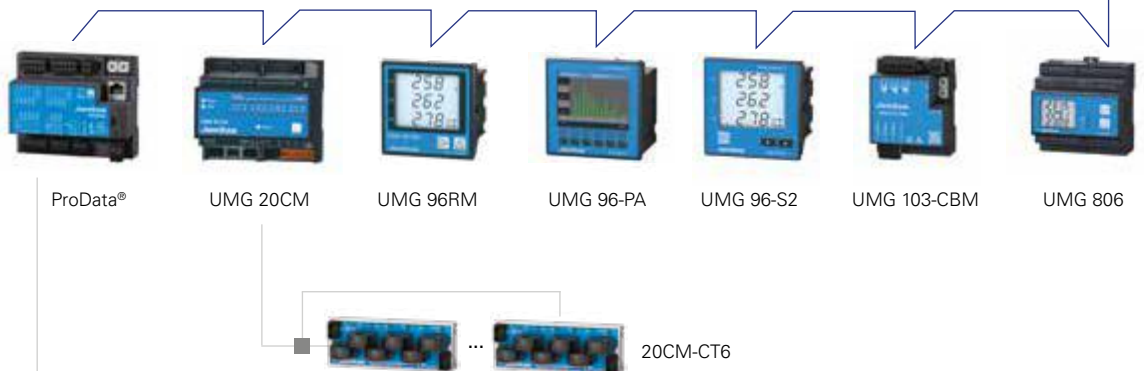

Analog / status / pulse input level

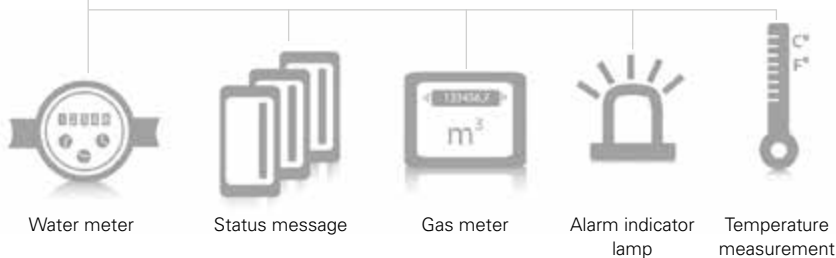



**FRONT PANEL
INSTALLATION MEASUREMENT DEVICES**



UMG 96-S2
Cost effective entry-level universal measurement device



UMG 96RM series
Multifunctional energy analyzer



UMG 96-PA series
Modularly expandable network analyzer (MID, meter reading cycle)



UMG 96RM-E
Multifunctional network analyzer with Ethernet and RCM



UMG 96-PQ-L
Modularly expandable network analyzer



UMG 509-PRO
Multifunctional power quality analyzer



UMG 512-PRO
Certified power quality analyzer (Class A/IEC 61000-4-30)

FRONT PANEL INSTALLATION MEASUREMENT DEVICES

Overviews	28	UMG 96-S2	Cost effective entry-level universal measurement device
	34	UMG 96RM series	Multifunctional energy analyzer
	42	UMG 96-PA series	Modularly expandable network analyzer (MID, meter reading cycle)
	62	UMG 96RM-E	Multifunctional power analyzer with Ethernet & RCM
	70	UMG 96-PQ-L	Modularly expandable network analyzer
	80	UMG 509-PRO	Multifunctional power quality analyzer
	88	UMG 512-PRO	Certified power quality analyzer (Class A according to IEC 61000-4-30)

COST EFFECTIVE ENTRY-LEVEL UNIVERSAL MEASUREMENT DEVICE

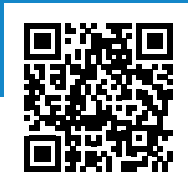

INTERFACES

- RS-485

PERIPHERY

- Digital output (S0 interface)
- 4 voltage measurement inputs
- 3 current measurement input

COMMUNICATION

- Modbus RTU

MEASURING ACCURACY

- Class 0.5S
- Current: 0.2%
- Voltage: 0.2%
- Sampling frequency: 8 kHz

POWER QUALITY

- Harmonics current up to the 15th harmonic

UMG 96-S2

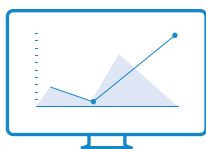

DISPLAY

Operation and configuration without opening the switchboard cabinet

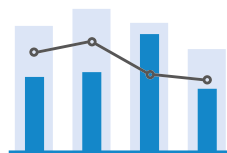

ENERGY MANAGEMENT

Very accurate measurement, high sampling frequency

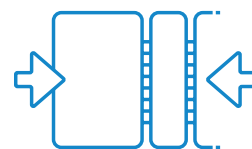

COMPACT

Reduced space requirement in the switchboard cabinet

UMG 96-S2 – DIMENSIONED DRAWING

All dimensions in mm

Bottom view

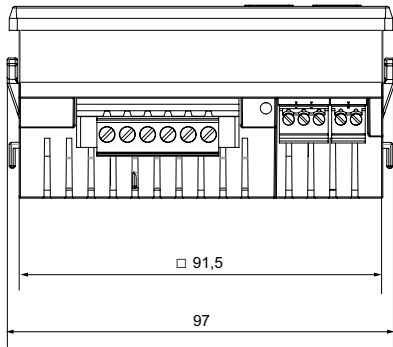

Cutout dimensions: $92^{+0.8} \times 92^{+0.8}$ mm

Side view

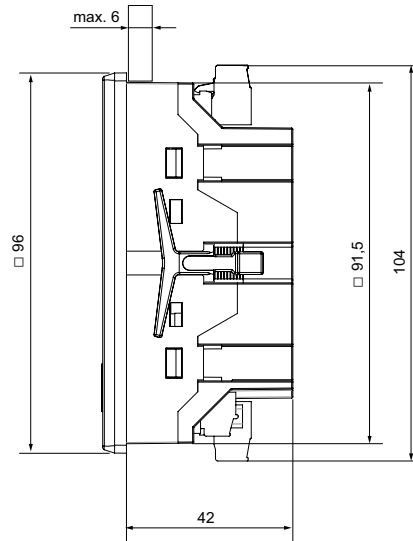

UMG 96-S2 – CONNECTION EXAMPLE

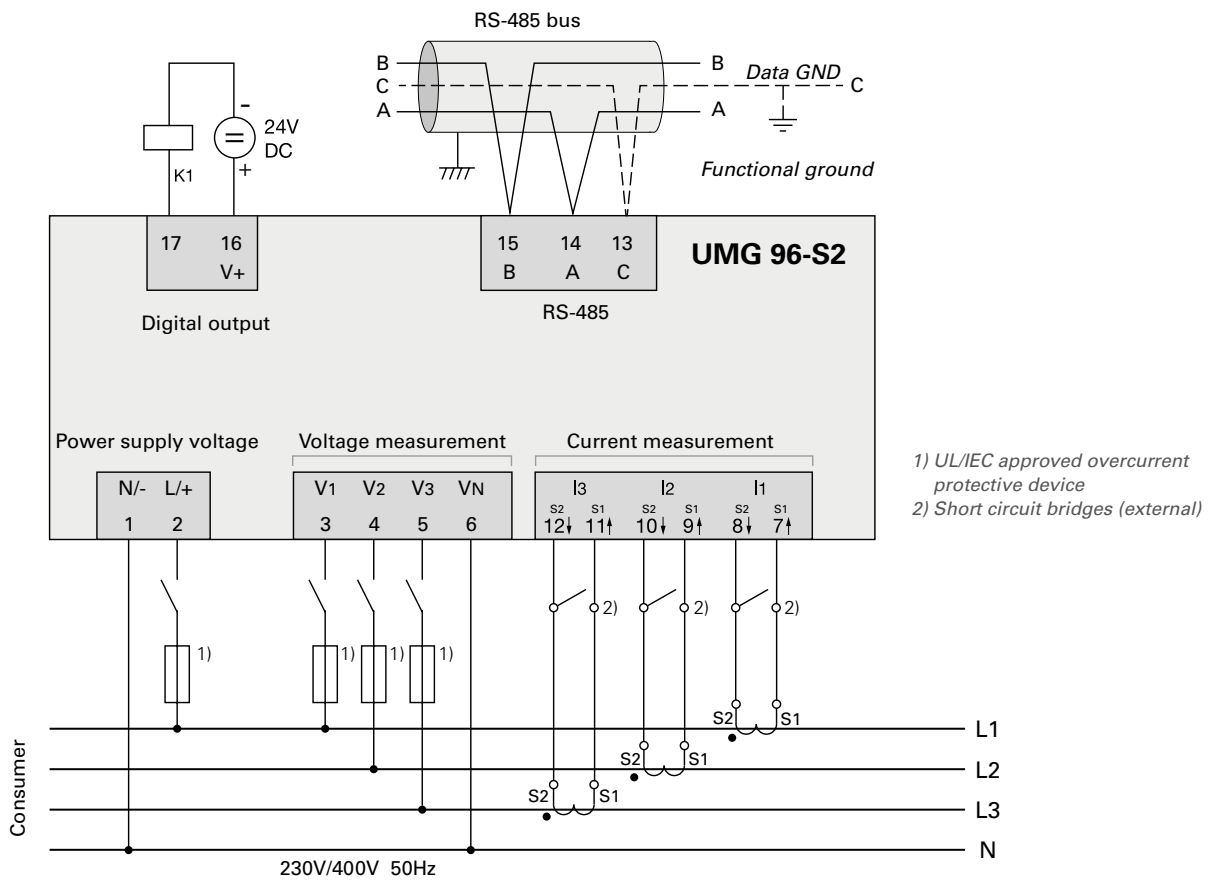

UMG 96-S2 – TECHNICAL DATA

UMG 96-S2	
PART NUMBER	5234002
GENERAL	
Net weight (with attached plug-in connectors)	approx. 250 g
Package weight (incl. accessories)	approx. 500 g
Impact resistance	IK07 according to IEC 62262
TRANSPORT AND STORAGE	
THE FOLLOWING SPECIFICATIONS APPLY FOR DEVICES TRANSPORTED AND STORED IN THE ORIGINAL PACKAGING.	
Free fall	1 m
Temperature	K55 (-25° C to +70° C)
Relative humidity	0 to 90% RH
ENVIRONMENTAL CONDITIONS DURING OPERATION	
The device:	
– is for weather-protected and stationary use.	
– Protection class II according to IEC 60536 (VDE 0106, Part 1).	
Rated temperature range	K55 (-10° C ... +55° C)
Relative humidity	0 to 75% RH
Operating elevation	0 – 2000 m (6562 ft) above sea level
Pollution degree	2
Mounting orientation	As desired
Ventilation	No forced ventilation required
Protection against foreign matter and water	
– Front	IP40 according to EN60529
– Rear	IP20 according to EN60529
– Front with seal	IP54 according to EN60529
SUPPLY VOLTAGE	
Nominal range	AC 90 V – 265 V (50/60 Hz) or DC 90 V – 250 V, 300 V CAT III
Operating range	± 10% of nominal range
Power consumption	max. 1.5 VA / 0.5 W
Internal fuse, not replaceable	Type T1A / 250 VDC / 277 VAC according to IEC 60127
Recommended overcurrent protective device for line protection	6-16 A, (Char. B, IEC-/UL approval)
VOLTAGE MEASUREMENT	
Three-phase 4-conductor systems with rated voltages up to	230 V/400 V (±10%) according to IEC
Overvoltage category	300 V CAT III
Rated surge voltage	4 kV
Protection of the voltage measurement	1 – 10 A (with IEC/UL approval)
Measuring range L-N	0 ^{III} ... 300 Vrms (max. overvoltage 400 Vrms)
Measuring range L-L	0 ^{III} .. 425 Vrms (max. overvoltage 620 Vrms)
Overrange L-N	$U_{L-N} > 300$ Vrms
Resolution	0.01 V
Crest factor	1.9 (referred to measuring range)
Impedance	3 MΩ/phase
Power consumption	approx. 0.1 VA
Sampling frequency	8 kHz
Frequency of fundamental oscillation – Resolution	45 Hz ... 65 Hz – 0.01 Hz

CURRENT MEASUREMENT

Nominal current	x/1 and x/5 A
Measuring range	0.005 .. 6 Aeff
Overrange	I > 7 Aeff
Crest factor (relative to the nominal current)	2
Resolution	1 mA (display 0.01 A) at .../5 A 1/4 mA at .../1 A
Overvoltage category	300 V CAT II
Rated surge voltage	2 kV
Power consumption	approx. 0.2 VA (Ri = 5 mΩ)
Overload for 1 s	60 A (sinusoidal)
Sampling frequency	8 kHz

SERIAL INTERFACE

RS-485 - Modbus RTU/Slave	9.6 kbps, 19.2 kbps, 38.4 kbps
---------------------------	--------------------------------

DIGITAL OUTPUT (1 digital output, solid state relays, not short-circuit proof)

Switching voltage	Max. 60 V DC
Switching current	max. 50 mAeff DC
Digital output (energy pulses)	max. 12.5 Hz

CONNECTION CAPACITY OF THE TERMINALS (SUPPLY VOLTAGE)

Connectible conductors (connect only one conductor per terminal!)

Single core, multi-core, fine-stranded	0.2 – 4 mm ² , AWG 28 –12
Wire ferrules (non-insulated)	0.2 – 4 mm ² , AWG 26 –12
Wire ferrules (insulated)	0.2 – 2.5 mm ² , AWG 26 –16
Tightening torque	0.4 – 0.5 Nm (3.54-4.43 lbf in)
Strip length	7 mm (0.2756 in)

CONNECTION CAPACITY OF THE TERMINALS (VOLTAGE MEASUREMENT)

Connectible conductors (connect only one conductor per terminal!)

Single core, multi-core, fine-stranded	0.2 – 4 mm ² , AWG 28 –12
Wire ferrules (non-insulated)	0.2 – 2.5 mm ² , AWG 26 –12
Wire ferrules (insulated)	0.2 – 2.5 mm ² , AWG 26 –16
Tightening torque	0.4 – 0.5 Nm (3.54-4.43 lbf in)
Strip length	7 mm (0.2756 in)

CONNECTION CAPACITY OF THE TERMINALS (CURRENT MEASUREMENT)

Connectible conductors (connect only one conductor per terminal!)

Single core, multi-core, fine-stranded	0.2 – 4 mm ² , AWG 28 –12
Wire ferrules (non-insulated)	0.2 – 2.5 mm ² , AWG 26 –12
Wire ferrules (insulated)	0.2 – 2.5 mm ² , AWG 26 –16
Tightening torque	0.4 – 0.5 Nm (3.54-4.43 lbf in)
Strip length	7 mm (0.2756 in)

CONNECTION CAPACITY OF THE TERMINALS (DIGITAL INTERFACE)

Connectible conductors (connect only one conductor per terminal!)

Single core, multi-core, fine-stranded	0.2 – 1.5 mm ² , AWG 28 –12
Wire ferrules (non-insulated)	0.2 – 1.5 mm ² , AWG 26 –12
Wire ferrules (insulated)	0.2 – 1.5 mm ² , AWG 26 –16
Tightening torque	0.2 – 0.25 Nm (1.77 - 2.21 lbf in)
Strip length	7 mm (0.2756 in)

CONNECTION CAPACITY OF THE TERMINALS (SERIAL INTERFACE)

Connectible conductors (connect only one conductor per terminal!)

Single core, multi-core, fine-stranded	0.2 – 1.5 mm ² , AWG 28 – 12
Wire ferrules (non-insulated)	0.2 – 1.5 mm ² , AWG 26 – 12
Wire ferrules (insulated)	0.2 – 1.5 mm ² , AWG 26 – 16
Tightening torque	0.2 – 0.25 Nm (1.77 - 2.21 lbf in)
Strip length	7 mm (0.2756 in)

1) The device only determines measured values if a voltage L1-N of greater than 20 Vrms (4-conductor measurement) or a voltage L1-L2 of greater than 34 Vrms (3-conductor measurement) is applied to voltage measurement input V1.

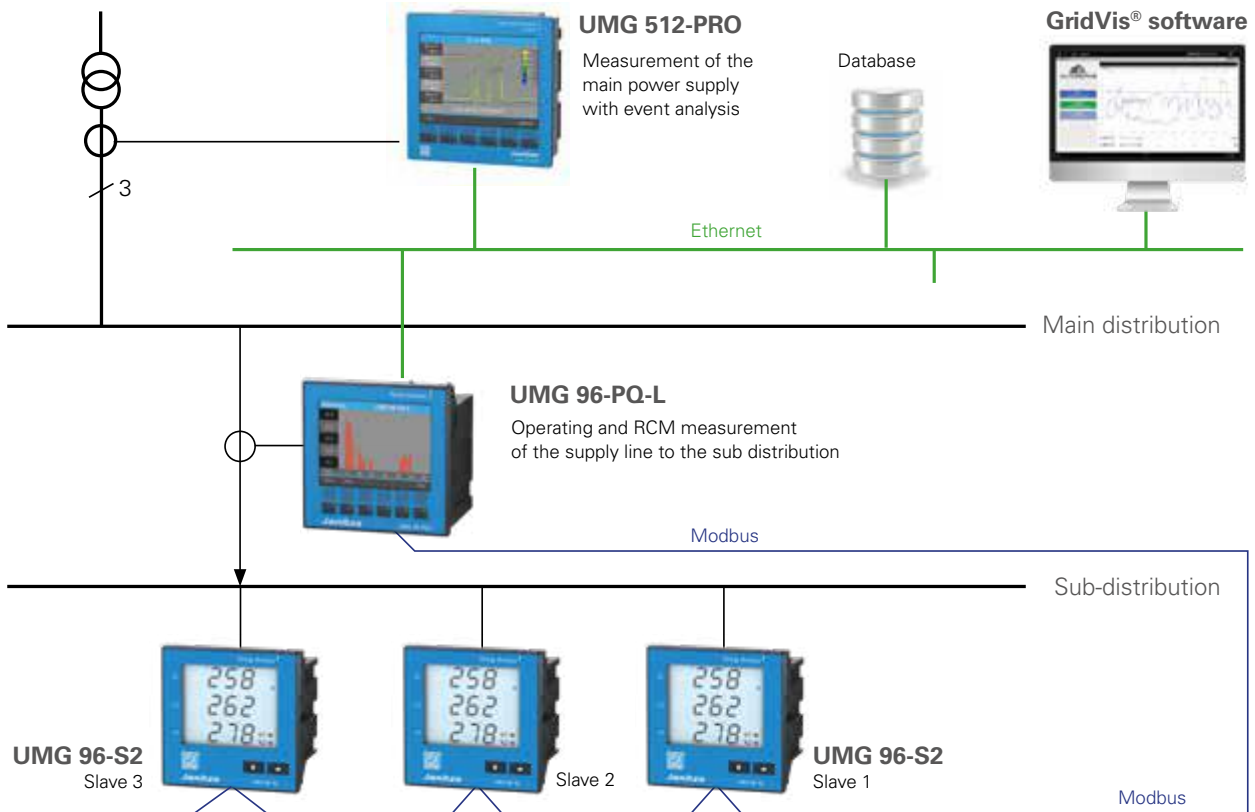
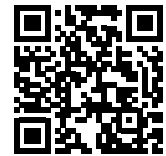

Fig.: Master slave principle

MULTIFUNCTIONAL ENERGY ANALYZER



INTERFACES (DEVICE SPECIFIC)

- RS-485
- Profibus
- Profinet
- M-Bus
- USB

COMMUNICATION (DEVICE SPECIFIC)

- Modbus RTU
- Profibus DP Vo
- Profinet
- TCP/IP
- M-Bus

POWER QUALITY

- Harmonics up to the 40th harmonic
- Rotating field components
- Distortion factor THD-U / THD-I

ENERGY MANAGEMENT

- Load profiles
- 8 tariffs

MEASURING ACCURACY

- Class 0.2S
- Current 0.2%
- Voltage 0.2%

UP TO 6 DIGITAL OUTPUTS

- Pulse output
- Switch output
- Limit value output
- Logic output
- Remote via Modbus/Profibus

UP TO 4 DIGITAL INPUTS

- Pulse input
- Logic input
- State monitoring

UMG 96RM SERIES

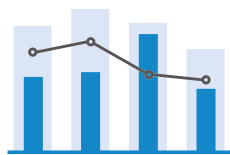

ENERGY MANAGEMENT

Extensive energy measurement data,
high accuracy: 0.5S active energy



COMMUNICATION

RS-485, Modbus RTU onboard in
basic device, various interfaces

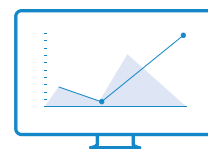

DISPLAY

Simple 2-button operation/
LED backlight

UMG 96RM – DIMENSIONED DRAWING

All dimensions in mm

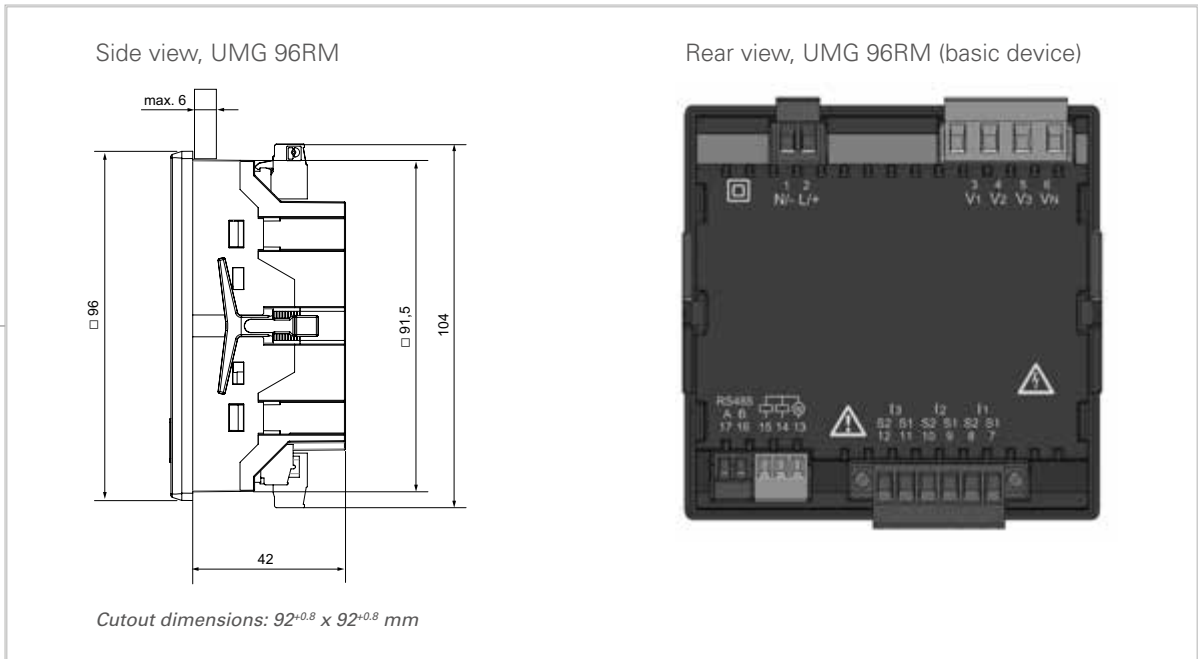

The illustrations shown here are examples. Further dimensional and connection diagrams can be requested or viewed on our homepage.

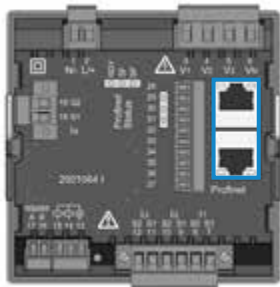

Rear view UMG 96RM-PN
Profinet variant

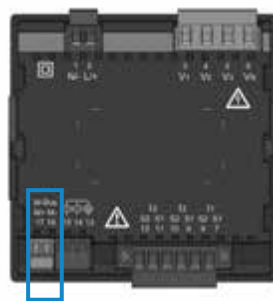

Rear view UMG 96RM-M
M-Bus variant

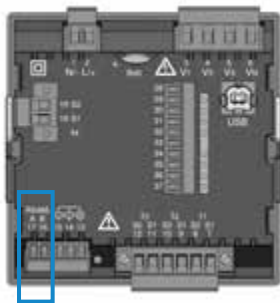

Rear view UMG 96RM-CBM
Modbus variant

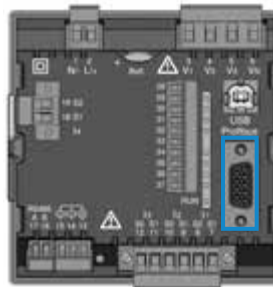

Rear view UMG 96RM-P
Profibus variant

UMG 96RM – CONNECTION EXAMPLE

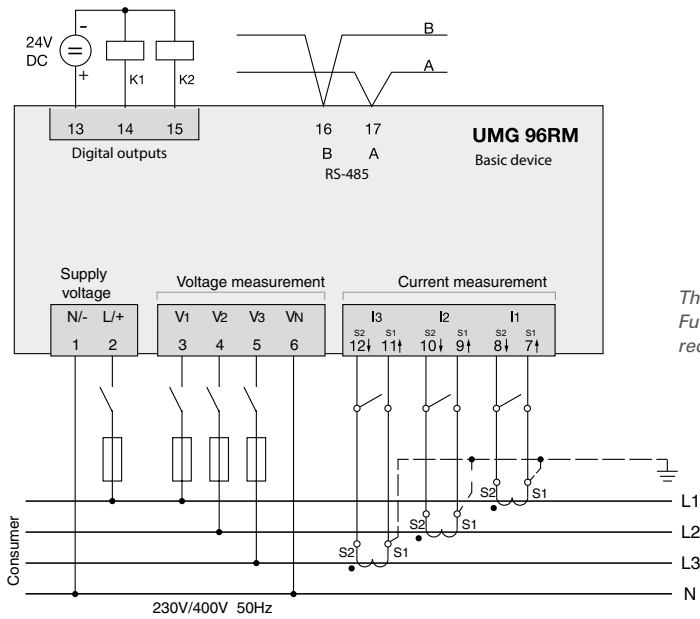

The illustration shown here is an example. Further connection diagrams can be requested or viewed on our homepage.



Fig.: Battery slot on the rear
(UMG 96RM-CBM and UMG 96RM-P)



Fig.: UMG 96RM-PN with Profinet interface

UMG 96RM SERIES – TECHNICAL DATA

	UMG 96RM*1	UMG 96RM-M*1	UMG 96RM-CBM*1	UMG 96RM-P*1	UMG 96RM-PN*1
PART NUMBER (90–277 VAC/90–250 VDC)	5222061	5222069	5222066	5222064	5222090
PART NUMBER (24–90 VAC/90–250 VDC)	5222070	5222073	5222067	5222065	5222091
Interfaces	RS-485	M-Bus	RS-485, USB	RS-485, Profibus, USB	RS-485, Ethernet, Profinet
PROTOCOLS					
Modbus RTU	•	–	•	•	•
Modbus TCP	–	–	–	–	•
Profibus DP V0	–	–	–	•	–
Profinet	–	–	–	–	•
M-Bus	–	•	–	–	–
DHCP or DCP	–	–	–	–	•
ICMP (ping)	–	–	–	–	•
MEASUREMENT DATA RECORDING					
Current measurement channels	3	3	4	4	4 (+2)
Memory size / recording duration (according to factory setting)	–	–	256 MB / approx. 2 months	256 MB / approx. 2 months	–
Battery	–	–	Type CR2032 3 V, Li-Mn	Type CR2032 3 V, Li-Mn	–
Clock	–	–	•	•	–
DIGITAL INPUTS AND OUTPUTS					
Digital inputs	–	–	4	4	3*3
Digital outputs (as switching or pulse output)	2	2	6	6	2 (+3)*3
MECHANICAL PROPERTIES					
Device dimensions in mm (W x H x D)*2	96 x 96 x approx. 48	96 x 96 x approx. 48	96 x 96 x approx. 78	96 x 96 x approx. 78	96 x 96 x approx. 78

Comment: For detailed technical information, please refer to the operating manual and the Modbus address list.

• = included – = not included

*1 UL certification included.

*2 For exact device dimensions, see operating manual.

*3 Optional 3 digital inputs or outputs (no pulse output)

GENERAL

Backlight service life	40000 h (50% of the original brightness)
------------------------	--

TRANSPORT AND STORAGE

The following information applies to devices that are transported or stored in their original packaging.

Free fall	1 m
Temperature	K55 (-25 °C to +70 °C) (-13 °F ..to 158 °F)
Relative humidity	0 to 90% RH

ENVIRONMENTAL CONDITIONS DURING OPERATION

The UMG 96RM is intended for weather-protected, stationary use.
Protection class II according to IEC 60536 (VDE 0106, Part 1).

Rated temperature range	K55 (-10 °C ... +55 °C) (14 °F ..to 131 °F)
Relative humidity	0 to 75% RH
Operating elevation	0 ... 2000 m above sea level
Pollution degree	2
Mounting orientation	As desired
Ventilation	No forced ventilation required
Protection against foreign matter and water	
– Front	IP40 according to EN60529
– Rear	IP20 according to EN60529
– Front with seal	IP54 according to EN60529

SUPPLY VOLTAGE

Option 230 V:	
Nominal range	90 V – 277 V (50/60 Hz) or DC 90 V – 250 V; 300 V CAT III
Power consumption	max. 4.5 VA / 2 W (RM-M) max. 5.5 VA / 3 W (RM) max. 6 VA / 3 W (RM-CBM) max. 7.5 VA / 4 W (RM-P) max. 8.5 VA / 5 W (RM-PN)

Option 24 V:	
Nominal range	24 V – 90 V AC / DC; 150 V CAT III
Power consumption	max. 2.5 VA / 2 W (RM-M) max. 4.5 VA / 3 W (RM) max. 5 VA / 3 W (RM-CBM) max. 6.5 VA / 5 W (RM-P) max. 7 VA / 5 W (RM-PN)

Operating range	±10% of nominal range
Internal fuse, not replaceable	Type T1A / 250 V/277 V according to IEC 60127
Recommended overcurrent protective device for the line protection (UL approval)	Option 230 V: 6 – 16 A Option 24 V: 1 – 6 A (Char. B)

CONNECTION CAPACITY OF THE TERMINALS (SUPPLY VOLTAGE)

Connectible conductors. Only one conductor may be connected per terminal!

Single core, multi-core, fine-stranded	0.2 – 2.5 mm ² , AWG 26 - 12
Terminal pins, wire ferrules	0.2 – 2.5 mm ²
Tightening torque	0.4 – 0.5 Nm (3.54 – 4.43 lbf in)
Strip length	7 mm (0.2756 in)
Measuring range L-N	0 ¹⁾ ... 300 Vrms (max. overvoltage 400 Vrms)

VOLTAGE MEASUREMENT

Three-phase 4-conductor systems with rated voltages up to	277 V/480 V ($\pm 10\%$)
Three-phase 3-conductor systems, non-grounded, with rated voltages up to	IT 480 V ($\pm 10\%$)
Overvoltage category	300 V CAT III
Rated surge voltage	4 kV
Measuring range L-N	0 ¹⁾ .. 300 Vrms (max. overvoltage 520 Vrms)
Measuring range L-L	0 ¹⁾ .. 520 Vrms (max. overvoltage 900 Vrms)
Resolution	0.01 V
Crest factor	2.45 (related to the measuring range)
Impedance	3 M Ω /phase
Power consumption	approx. 0.1 VA
Sampling frequency	21.33 kHz (50 Hz), 25.6 kHz (60 Hz) per measurement channel
Frequency of the fundamental oscillation	45 Hz ... 65 Hz
Resolution	0.01 Hz

1) The UMG 96RM can only determine measured values if a voltage L1-N of greater than 20 Vrms (4-wire measurement) or a voltage L1-L2 of greater than 34 Vrms (3-wire measurement) is present at voltage measurement input V1.

CONNECTION CAPACITY OF THE TERMINALS (VOLTAGE MEASUREMENT)

Connectible conductors. Only one conductor may be connected per terminal!

Single core, multi-core, fine-stranded	0.2 – 2.5 mm ² , AWG 26 - 12
Terminal pins, wire ferrules	0.2 – 2.5 mm ²
Tightening torque	0.4 – 0.5 Nm (3.54 – 4.43 lbf in)
Strip length	7 mm (0.2756 in)

CURRENT MEASUREMENT

Nominal current	5 A
Measuring range	0 ... 6 Arms
Crest factor	1.98
Resolution	0.1 mA (display 0.01 A)
Overvoltage category	300 V CAT II
Rated surge voltage	2 kV
Power consumption	approx. 0.2 VA (Ri = 5 m Ω)
Overload for 1 s	120 A (sinusoidal)
Sampling frequency	21.33 kHz (50 Hz), 25.6 kHz (60 Hz) per measurement channel

CONNECTION CAPACITY OF THE TERMINALS (VOLTAGE MEASUREMENT)

Connectible conductors. Only one conductor may be connected per terminal!

Single core, multi-core, fine-stranded	0.08 – 4 mm ² , AWG 26 - 12
Terminal pins, wire ferrules	0.2 – 2.5 mm ²
Tightening torque	0.4 – 0.5 Nm (3.54 – 4.43 lbf in)
Strip length	7 mm (0.2756 in)

SERIAL INTERFACE

RS485 - Modbus RTU/slave	9.6kbps, 19.2kbps, 38.4kbps, 57.6 kbps, 115.2kbps
Stripping length	7 mm

CONNECTION CAPACITY OF THE TERMINALS (SERIAL INTERFACE)

Connectible conductors. Only one conductor may be connected per terminal!

Single core, multi-core, fine-stranded	0.2 – 1.5 mm ²
Terminal pins, wire ferrules	0.2 – 1.5 mm ²
Tightening torque	0.2 – 0.25 Nm (1.77 - 2.21 lbf in)
Strip length	7 mm (0.2756 in)

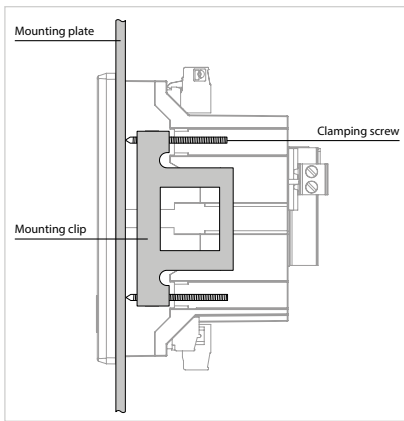

Fig.: The mounting into a switchboard is done via the lateral fastening clips (UMG 96RM-P / UMG 96RM-CBM)

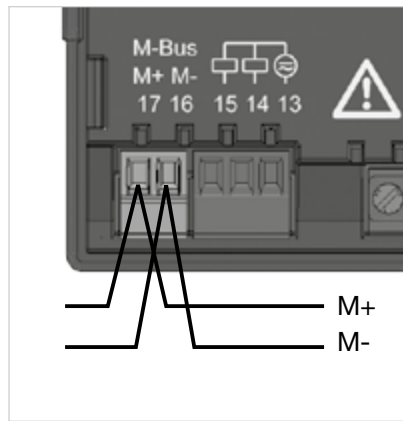
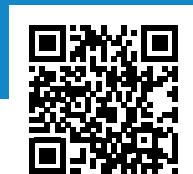

Fig.: M-Bus interface with 2-pole plug contact



Fig.: 2-pole plug contact with cable connection (cable type: 2 x 0.75 mm²) via twin wire ferrules

MODULARLY EXPANDABLE NETWORK ANALYZER



MODULAR

- Plug-on module
- Temperature measurement
- 4th current input
- 2 residual current inputs
- Ethernet interface

INTERFACES

- RS-485

OVERVOLTAGE CATEGORY

- 600 V CAT III

MEASUREMENT DATA MEMORY

- 8 MB / approx. 3 months;
MID+ meter reading cycle:
approx. 24 months (according
to factory setting)

MEASURING ACCURACY

- Class 0.2S
- Current: 0.2%
- Voltage: 0.2%

POWER QUALITY

- Harmonics current up to
the 40th harmonic
- Distortion factor THD-U/THD-I

PERIPHERALS

- 3 digital inputs and outputs
- 1 analog output

COLOR GRAPHIC DISPLAY

- 6-button operation
- Measured values numerically,
as diagram or graph
- Intuitive operation

UMG 96-PA

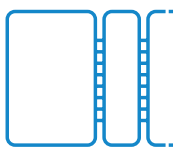

MODULAR

Future-proof thanks to retrofittable modules

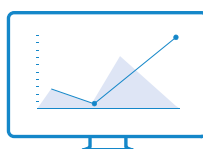

DISPLAY

Device configuration via color graphic display & 6-button operation



SAFETY

High dielectric strength of 600 V CAT III

UMG 96-PA – DIMENSIONED DRAWING

All dimensions in mm

Side view

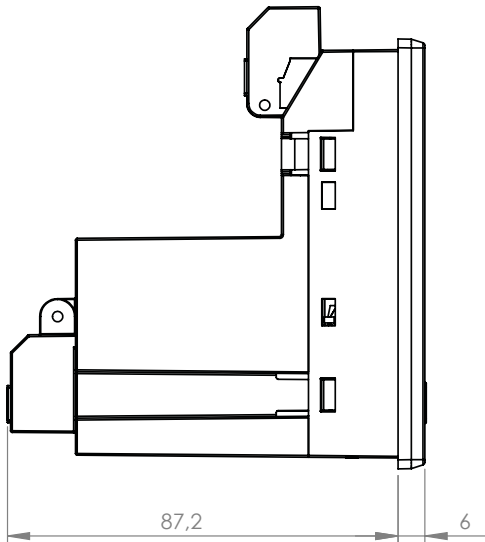

Bottom view

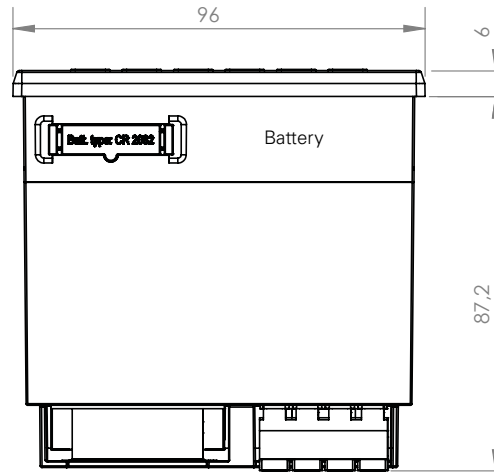

Cutout dimensions: 92^{+0.8} x 92^{+0.8} mm

UMG 96-PA – CONNECTION EXAMPLE

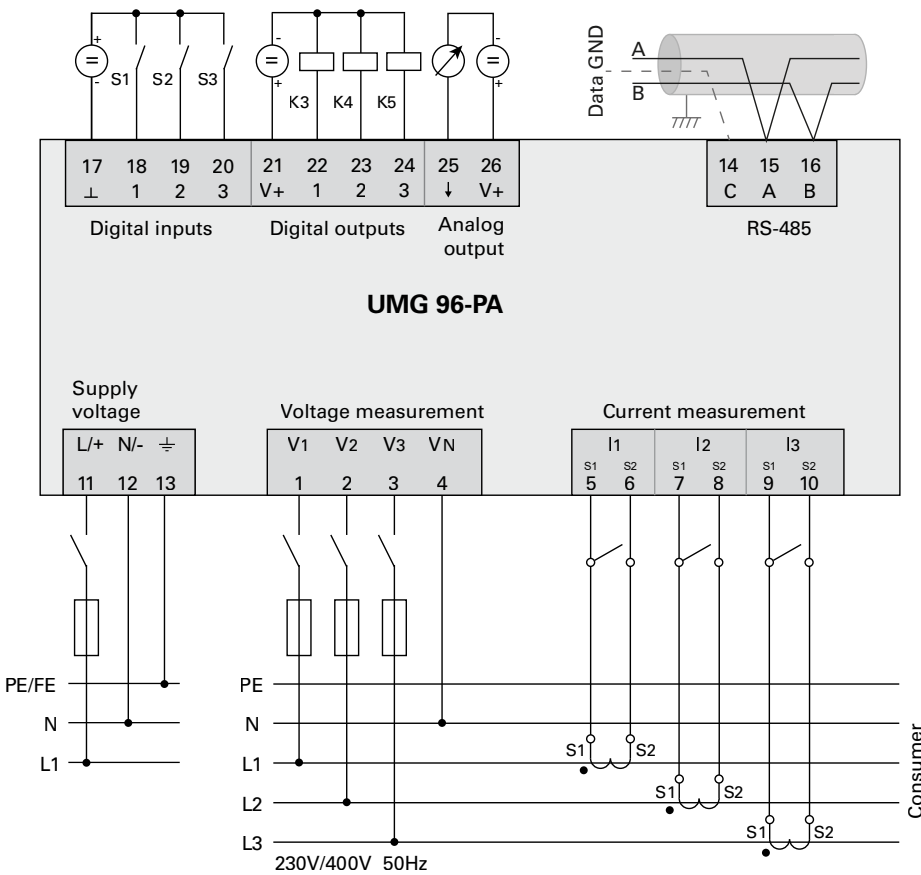

UMG 96-PA – TECHNICAL DATA

UMG 96-PA (basic device without MID)	
PART NUMBER (90–277 VAC / 90–250 VDC)	5232001
PART NUMBER (24–90 VAC / 24–90 VDC)	5232002

GENERAL

Net weight (with attached plug-in connectors)	approx. 250 g (0.55 lbs)
Package weight (incl. accessories)	approx. 500 g (1.1 lbs)
Battery	Type Lithium CR2032, 3 V, (UL 1642 approved)
Data memory	8 MB
Backlight service life	40000 h (backlight reduces to approx. 50% over this period)
Impact resistance	IK07 according to IEC 62262

TRANSPORT AND STORAGE

The following information applies to devices that are transported or stored in their original packaging.

Free fall	1 m (39.37 in)
Temperature	–25 °C (–13 °F) to +70 °C (158 °F)
Relative air humidity (non-condensing)	0 to 90% RH

ENVIRONMENTAL CONDITIONS DURING OPERATION

Install the device in a weather-protected and stationary location.
Protection class II according to IEC 60536 (VDE 0106, Part 1).

Rated temperature range	–10 °C (14 °F) ... +55 °C (131 °F)
Relative air humidity (non-condensing)	0 to 75% RH
Operating elevation	0 ... 2000 m (6562 ft) above sea level
Pollution degree	2
Mounting orientation	As desired
Ventilation	No forced ventilation required
Protection against foreign matter and water	
– Front	IP40 according to EN60529
– Rear	IP20 according to EN60529
– Front with seal	IP54 according to EN60529

SUPPLY VOLTAGE

Option 230 V:	
Nominal range	AC 90 V – 277 V (50/60 Hz) or DC 90 V – 250 V, 300 V CATIII
Power consumption	max. 4.5 VA / 2 W
Option 24 V*:	
Nominal range	AC 24 V – 90 V (50/60 Hz) or DC 24 V – 90 V, 150 V CATIII
Power consumption	max. 4.5 VA / 2 W
Operating range	± 10% of nominal range
Internal fuse, not replaceable	Type T1A / 250 V DC / 277 V AC according to IEC 60127
Recommended overcurrent protective device for the line protection (UL approval)	Option 230 V: 6 – 16 A (Char. B) Option 24 V*: 1 – 6 A (Char. B)

***The 24 V option only applies to the UMG 96-PA!**

Recommendation for the maximum number of devices on a line circuit breaker:

Option 230 V: Line circuit breaker B6A: max. 4 devices / line circuit breaker B16A: max. 11 devices

Option 24 V: Line circuit breaker B6A: max. 3 devices / line circuit breaker B16A: max. 9 devices

VOLTAGE MEASUREMENT

Three-phase 4-conductor systems with rated voltages up to	417 V / 720 V ($\pm 10\%$) according to IEC 347 V / 600 V ($\pm 10\%$) according to UL
Three-phase 3-conductor systems with rated voltages up to	600 V ($\pm 10\%$)
Single-phase 2-conductor system with rated voltages up to	480 V ($\pm 10\%$)
Overvoltage category	600 V CAT III
Rated surge voltage	6 kV
Protection of the voltage measurement	1–10 A tripping characteristic B (with IEC/UL approval)
Measuring range L-N	0 ¹⁾ .. 600 V _{rms} (max. overvoltage 800 V _{rms})
Measuring range L-L	0 ¹⁾ .. 1040 V _{rms} (max. overvoltage 1350 V _{rms})
Resolution	0.01 V
Crest factor	2.45 (related to the measuring range)
Impedance	3 M Ω /phase
Power consumption	approx. 0.1 VA
Sampling frequency	8.13 kHz
Frequency of the fundamental oscillation	45 Hz ... 65 Hz
- Resolution	0.01 Hz
Fourier analysis	1st – 40th harmonic

1) The device only determines measured values if a voltage L1-N of greater than 20 V_{rms} (4-conductor measurement) or a voltage L1-L2 of greater than 34 V_{rms} (3-conductor measurement) is applied to voltage measurement input V1.

CURRENT MEASUREMENT

Nominal current	5 A
Measuring range	0.005 .. 6 A _{rms}
Crest factor	2 (relative to 6 A _{rms})
Overvoltage category	300 V CAT II
Rated surge voltage	2.5 kV
Power consumption	approx. 0.2 VA (R _i =5 m Ω)
Overload for 1 s	60 A (sinusoidal)
Resolution	0.1 mA (display 0.01 A)
Sampling frequency	8.13 kHz
Fourier analysis	1st – 40th harmonic

SERIAL INTERFACE

RS-485 - Modbus RTU/Slave	9.6 kbps, 19.2 kbps, 38.4 kbps, 57.6 kbps, 115.2 kbps
---------------------------	---

DIGITAL OUTPUTS

3 digital outputs, solid state relays, not short-circuit proof.

Switching voltage	max. 33 V AC, 40 V DC
Switching current	max. 50 mA _{eff} AC/DC
Response time	approx. 200 ms
Pulse output	max. 50 Hz (energy pulses)

Digital output 1 (terminal 21/22) of the UMG 96-PA-MID+ provides the active energy (applied/delivered) measured value!

DIGITAL INPUTS

3 digital inputs, solid state relays, not short-circuit proof.

Maximum counter frequency	20 Hz
Input signal applied	18 V .. 28 V DC (typically 4 mA)
Input signal not applied	0 .. 5 V DC, current less than 0.5 mA

CABLE LENGTH (DIGITAL INPUTS/OUTPUTS)

Up to 30 m (32.81 yd)	Unshielded
Greater than 30 m (32.81 yd)	Shielded

ANALOG OUTPUTS

External power supply	max. 33 V
Current	0 ... 20 mA
Update time	1 s
Load	max. 300 Ω
Resolution	10 bit

CONNECTION CAPACITY OF THE TERMINALS (SUPPLY VOLTAGE)

Connectible conductors. Only connect one conductor per terminal!

Single core, multi-core, fine-stranded	0.2 – 4.0 mm ² , AWG 28-12
Wire ferrules (non-insulated)	0.2 – 2.5 mm ² , AWG 26-14
Wire ferrules (insulated)	0.2 – 2.5 mm ² , AWG 26-14
Tightening torque	0.4 – 0.5 Nm (3.54 – 4.43 lbf in)
Strip length	7 mm (0.2756 in)

CONNECTION CAPACITY OF THE TERMINALS (VOLTAGE MEASUREMENT)

Connectible conductors. Only connect one conductor per terminal!

Single core, multi-core, fine-stranded	0.2 – 4.0 mm ² , AWG 28-12
Wire ferrules (non-insulated)	0.2 – 2.5 mm ² , AWG 26-14
Wire ferrules (insulated)	0.2 – 2.5 mm ² , AWG 26-14
Tightening torque	0.4 – 0.5 Nm (3.54 – 4.43 lbf in)
Strip length	7 mm (0.2756 in)

CONNECTION CAPACITY OF THE TERMINALS (CURRENT MEASUREMENT)

Connectible conductors. Only connect one conductor per terminal!

Single core, multi-core, fine-stranded	0.2 – 4 mm ² , AWG 28-12
Wire ferrules (non-insulated)	0.2 – 2.5 mm ² , AWG 26-14
Wire ferrules (insulated)	0.2 – 2.5 mm ² , AWG 26-14
Tightening torque	0.4 – 0.5 Nm (3.54 – 4.43 lbf in)
Strip length	7 mm (0.2756 in)

TERMINAL CONNECTION CAPACITY (SERIAL INTERFACE)

Connectible conductors. Only connect one conductor per terminal!

Single core, multi-core, fine-stranded	0.2 – 1.5 mm ² , AWG 28-16
Wire ferrules (non-insulated)	0.2 – 1.5 mm ² , AWG 26-16
Wire ferrules (insulated)	0.2 – 1.5 mm ² , AWG 26-16
Tightening torque	0.2 – 0.25 Nm (1.77 – 2.21 lbf in)
Strip length	7 mm (0.2756 in)

CONNECTION CAPACITY OF THE TERMINALS (DIGITAL INPUTS / OUTPUTS, ANALOG OUTPUT)

Connectible conductors. Only connect one conductor per terminal!

Single core, multi-core, fine-stranded	0.2 – 1.5 mm ² , AWG 28-16
Wire ferrules (non-insulated)	0.2 – 1.5 mm ² , AWG 26-16
Wire ferrules (insulated)	0.2 – 1.5 mm ² , AWG 26-16
Tightening torque	0.2 – 0.25 Nm (1.77 – 2.21 lbf in)
Strip length	7 mm (0.2756 in)

MODULAR EXPANSION FOR THE UMG 96-PA METER

Module 96-PA-RCM-EL

- Ethernet interface
- 2 residual current inputs
- Temperature measurement
- 4th current input
- DC measurement



MODULE 96-PA-RCM-EL – MODULE CONNECTIONS

Front view

Rear view

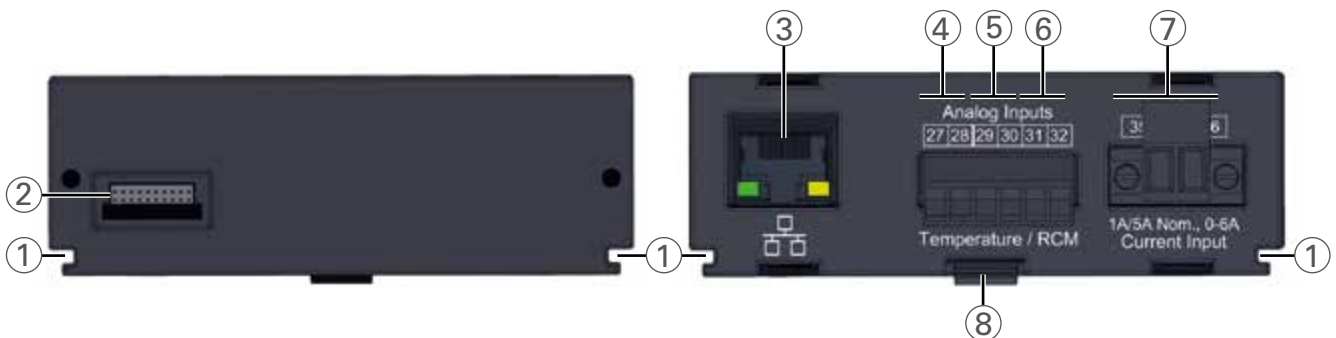

NO.	DESIGNATION	DESCRIPTION
1	Groove	Guide groove for the mounting/dismantling of the module
2	Module connector	Interface to basic device
3	RJ45	Only module 96-PA-RCM-EL: Ethernet interface (10/100Base-T)
4	Analog inputs - terminals 27 / 28	Temperature measurement
5	Analog inputs - terminals 29 / 30	Residual current measurement I5
6	Analog inputs - terminals 31 / 32	Residual current measurement I6 or voltage measurement U6 for the DC power
7	Current measurement input - terminals 35 / 36	Current measurement I4
8	Snapping mechanism	For mounting/removal of the module (snap in/snap out).

MODULE 96-PA-RCM-EL – CONNECTION EXAMPLE

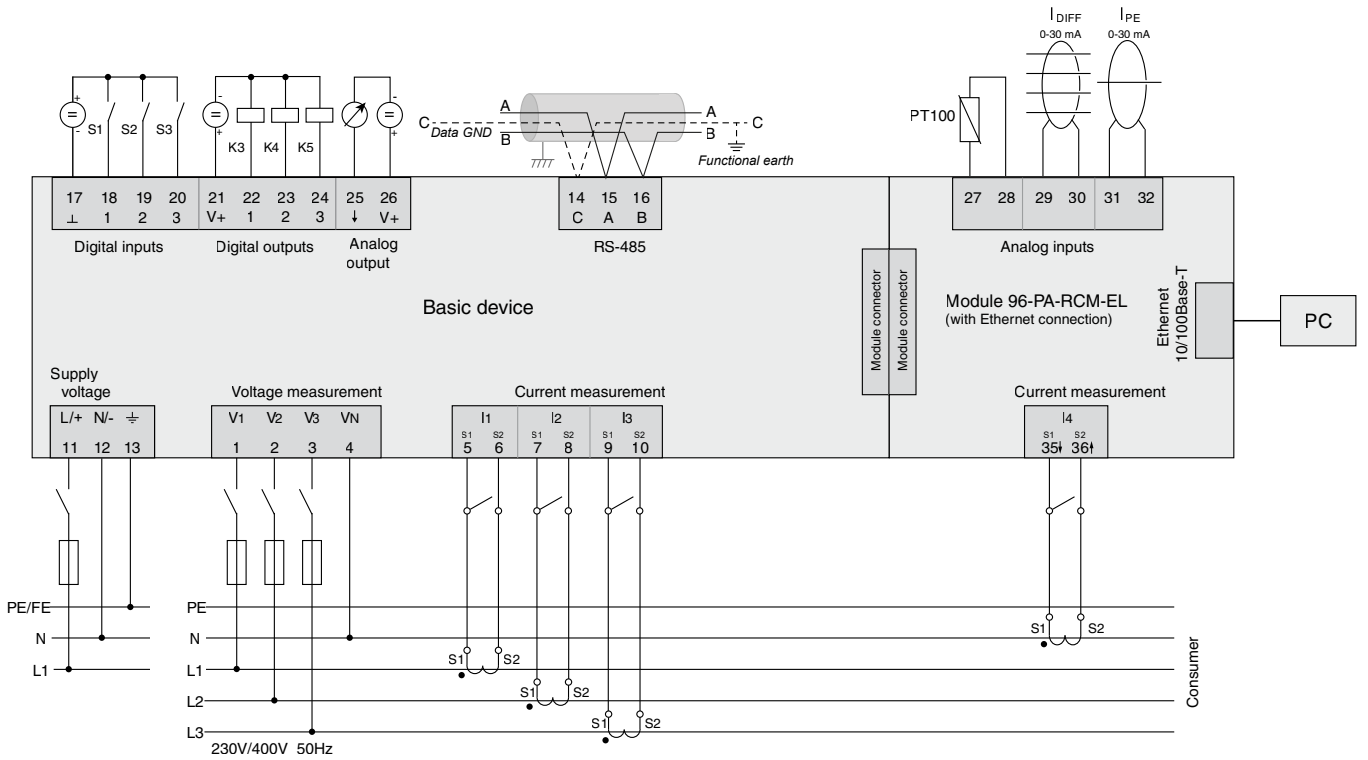

Fig.: Connection example "Basic device with module 96-PA-RCM-EL"
 Information on overcurrent devices can be found in the user manual of your basic device

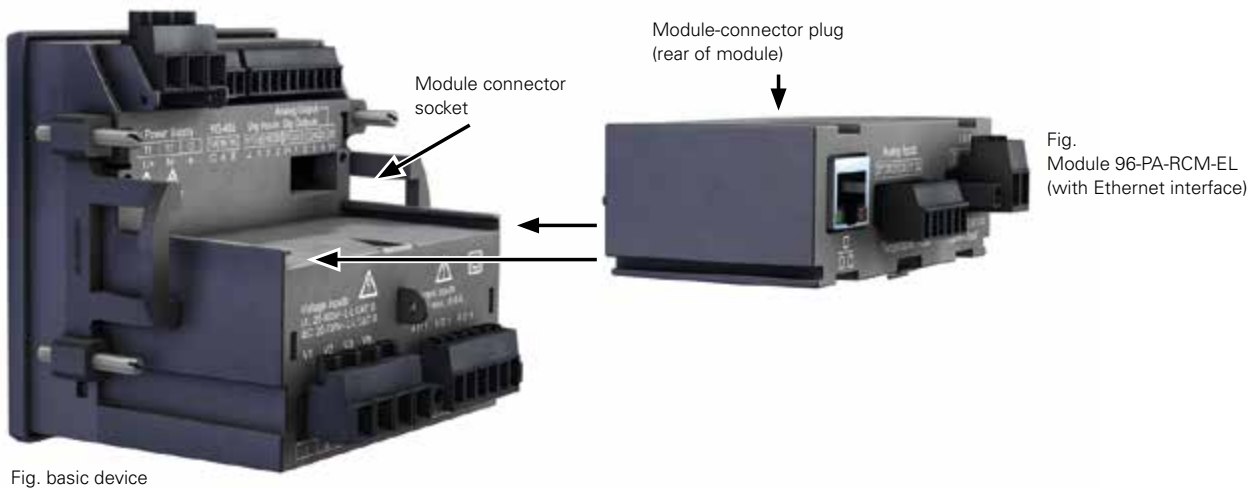

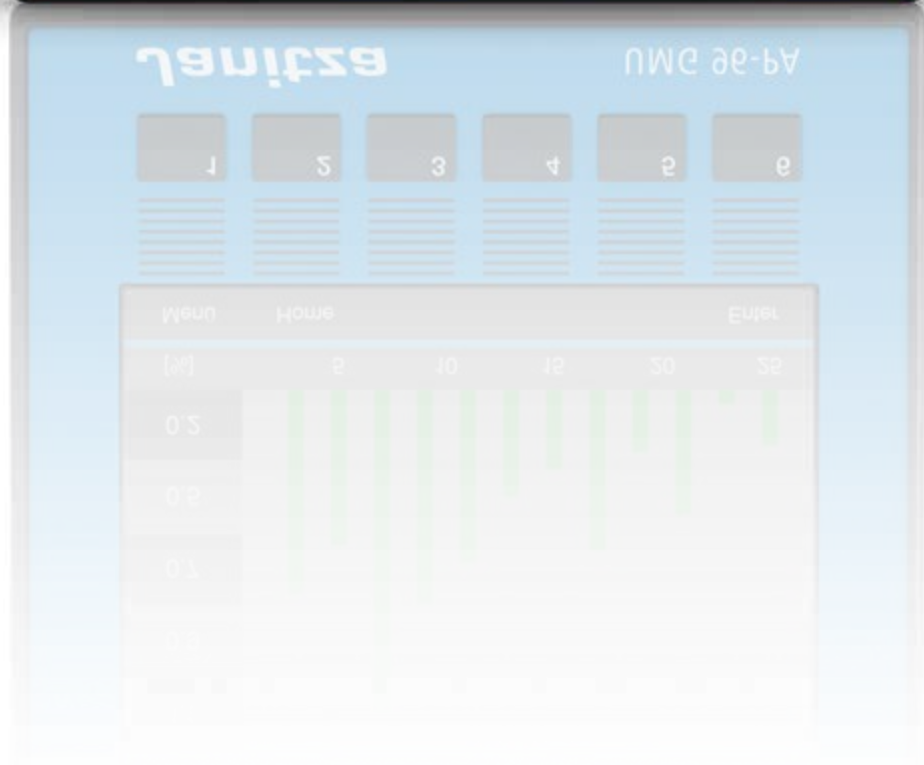
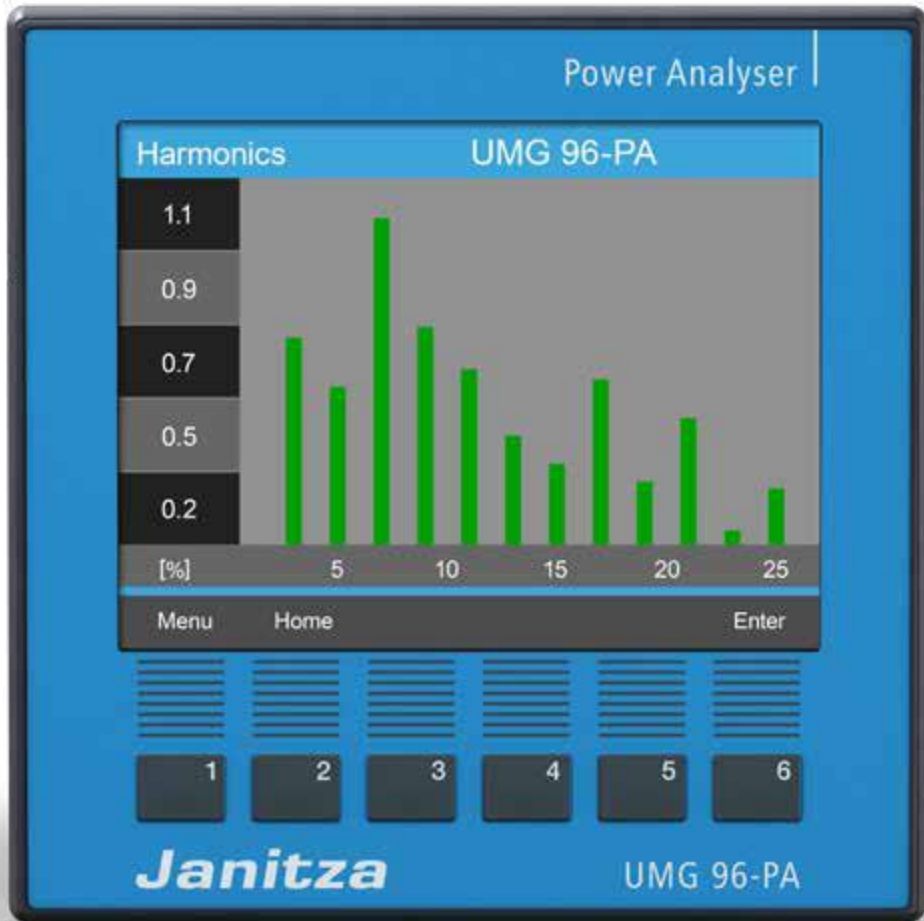

Fig. basic device

Fig. Module 96-PA-RCM-EL (with Ethernet interface)

MODULE 96-PA-RCM-EL – TECHNICAL DATA

MODULE 96-PA-RCM-EL WITH ETHERNET CONNECTION			
PART NUMBER		5232010	
GENERAL			
Net weight of module (with attached plug-in connectors)	78 g (0.17 lbs)		
Impact resistance	IK07 according to IEC 62262		
TRANSPORT AND STORAGE			
The following specifications apply for devices transported and stored in the original packaging.			
Free fall	1 m (39.37 in)		
Temperature	K55 –25 °C (–13 °F) to +70 °C (158 °F)		
Relative air humidity (non-condensing)	0 to 90% RH		
<i>Environmental conditions during operation, see the usage information for your basic device.</i>			
ANALOG INPUTS			
Differential or current signals	2x		
Temperature measurement	1x		
RESIDUAL CURRENT INPUT			
Nominal current	30 mArms 0 ... 20 mA 4 ... 20 mA		
Measuring range	0 ... 30 mArms		
Operating current	50 µA		
Resolution	1 µA		
Cable break detection (failure monitoring)	Can be activated		
Crest factor	1.414 (relative to 30 mA)		
Load	4 Ω		
Overload for 1 s	1 A		
Constant overloaded	200 mA		
According to IEC/TR 60755 (2008-01):			
Measurement of residual currents	Type A		
	Type B and B+		
TEMPERATURE MEASUREMENT			
Update time	200 ms		
Suitable thermal sensor	PT100, PT1000, KTY83, KTY84		
Total burden (thermal sensor and lead)	max. 4 kΩ		
THERMAL SENSOR TYPE	TEMPERATURE RANGE	RESISTANCE RANGE	MEASUREMENT UNCERTAINTY
PT100	–99 °C (–146.2 °F) ... +500 °C (932 °F)	60 Ω ... 180 Ω	±1.5% rng
PT1000	–99 °C (–146.2 °F) ... +500 °C (932 °F)	600 Ω ... 1.8 kΩ	±1.5% rng
KTY83	–55 °C (–67 °F) ... +175 °C (347 °F)	500 Ω ... 2.6 kΩ	±1.5% rng
KTY84	–40 °C (–40 °F) ... +300 °C (572 °F)	350 Ω ... 2.6 kΩ	±1.5% rng



MODULARLY EXPANDABLE NETWORK ANALYZER

(MID, METER READING CYCLE)



CERTIFICATION

- MID-compliant and tamper-proof
- Meter reading cycle to PTB-A 50.7
- Updateable according to MID guidelines (software separation)

EEG

- Legally valid billing & acquisition
- Self-supplier & users of the BesAR

INTERFACES

- RS-485

MODULAR

- Plug-on module
- Temperature measurement
- 4th current input
- 2 residual current inputs
- Ethernet interface

OVERVOLTAGE CATEGORY

- 600 V CAT III

MEASURING ACCURACY

- Class 0.2S
- Current: 0.2%
- Voltage: 0.2%

POWER QUALITY

- Harmonics current up to the 40th harmonic
- Distortion factor THD-U/THD-I

PERIPHERALS

- 3 digital inputs and outputs
- 1 analog output

MEASUREMENT DATA MEMORY

- 8 MB / 400,000 measured values and two years of meter reading cycle values

UMG 96-PA^{MID+}



CERTIFICATION

VDE-tested meter reading cycle measurement according to PTB-A 50.7

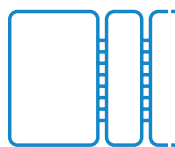

MODULAR

Future-proof thanks to retrofittable modules and firmware

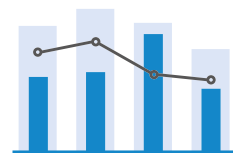

ENERGY MANAGEMENT

Standard compliance for secure reimbursement of the EEG apportionment

UMG 96-PA-MID – DIMENSIONED DRAWING

All dimensions in mm

Side view

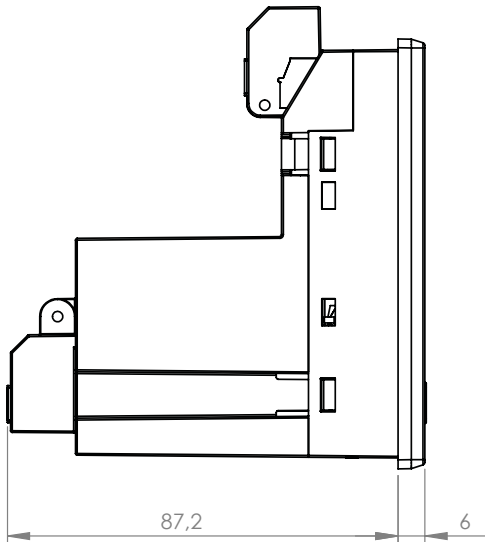

Bottom view

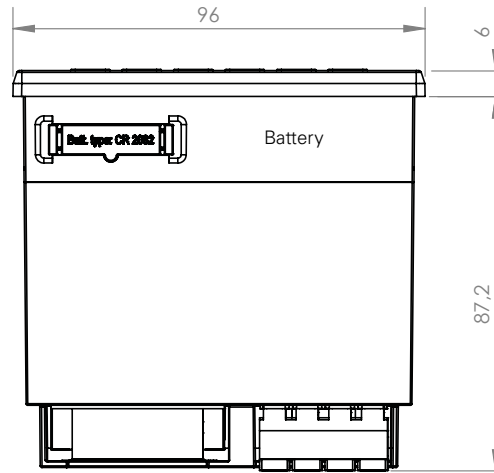

Cutout dimensions: 92^{+0.8} x 92^{+0.8} mm

UMG 96-PA-MID+ – CONNECTION EXAMPLE

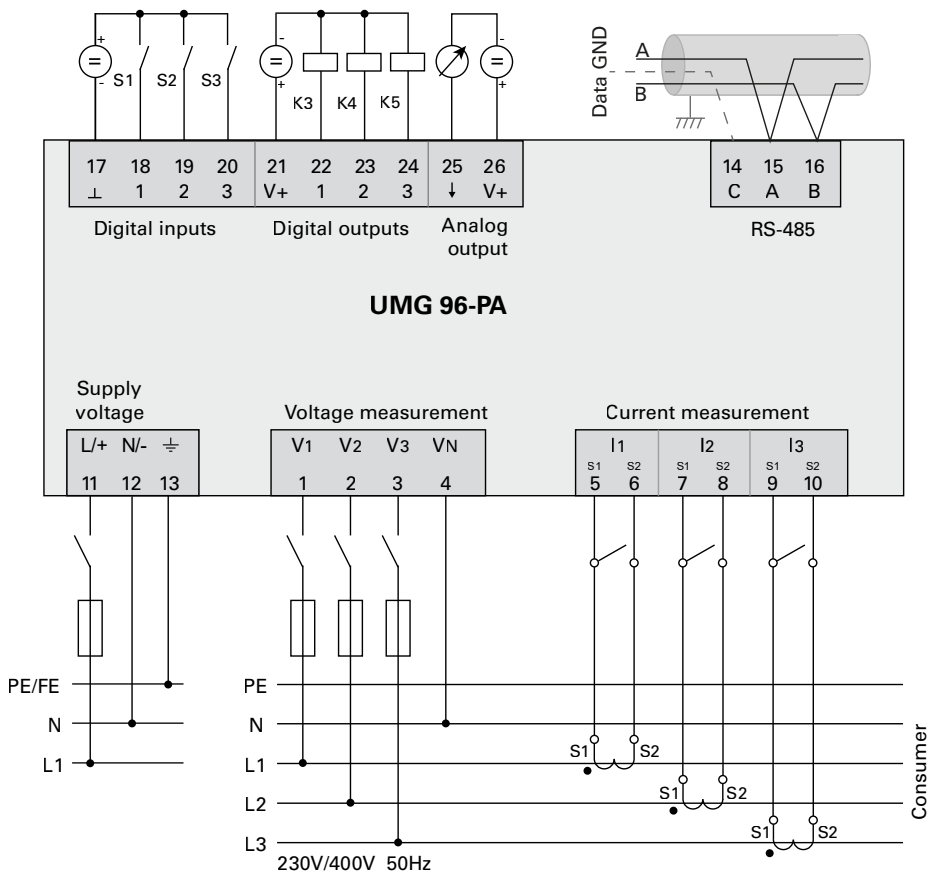

UMG 96-PA-MID+ – TECHNICAL DATA

UMG 96-PA-MID+ (basic device with MID and meter reading cycle)	
PART NUMBER (90–277 VAC / 90–250 VDC)	5232004

GENERAL

Net weight (with attached plug-in connectors)	approx. 250 g (0.55 lbs)
Package weight (incl. accessories)	approx. 500 g (1.1 lbs)
Battery	Type Lithium CR2032, 3 V, (UL 1642 approved)
Data memory	8 MB
Backlight service life	40000 h (backlight reduces to approx. 50% over this period)
Impact resistance	IK07 according to IEC 62262

TRANSPORT AND STORAGE

The following information applies to devices that are transported or stored in their original packaging.

Free fall	1 m (39.37 in)
Temperature	–25 °C (–13 °F) to +70 °C (158 °F)
Relative air humidity (non-condensing)	0 to 90% RH

ENVIRONMENTAL CONDITIONS DURING OPERATION

Install the device in a weather-protected and stationary location.
Protection class II according to IEC 60536 (VDE 0106, Part 1).

Rated temperature range	–10 °C (14 °F) ... +55 °C (131 °F)
Relative air humidity (non-condensing)	0 to 75% RH
Operating elevation	0 ... 2000 m (6562 ft) above sea level
Pollution degree	2
Mounting orientation	As desired
Ventilation	No forced ventilation required
Protection against foreign matter and water	
– Front	IP40 according to EN60529
– Rear	IP20 according to EN60529
– Front with seal	IP54 according to EN60529

SUPPLY VOLTAGE

Option 230 V:	
Nominal range	AC 90 V – 277 V (50/60 Hz) or DC 90 V – 250 V, 300 V CATIII
Power consumption	max. 4.5 VA / 2 W
Operating range	±10% of nominal range
Internal fuse, not replaceable	Type T1A / 250 V DC / 277 V AC according to IEC 60127
Recommended overcurrent protective device for the line protection (UL approval)	Option 230 V: 6 – 16 A (Char. B)

Recommendation for the maximum number of devices on a line circuit breaker:

Option 230 V: Line circuit breaker B6A: max. 4 devices / line circuit breaker B16A: max. 11 devices

VOLTAGE MEASUREMENT

Three-phase 4-conductor systems with rated voltages up to	417 V / 720 V ($\pm 10\%$) according to IEC 347 V / 600 V ($\pm 10\%$) according to UL MID: see table „183 Operating current transformers“ on page 17
Three-phase 3-conductor systems with rated voltages up to	600 V ($\pm 10\%$)
Single-phase 2-conductor system with rated voltages up to	480 V ($\pm 10\%$)
Overvoltage category	600 V CAT III
Rated surge voltage	6 kV
Protection of the voltage measurement	1–10 A tripping characteristic B (with IEC/UL approval)
Measuring range L-N	0 ¹⁾ .. 600 V _{rms} (max. overvoltage 800 V _{rms})
Measuring range L-L	0 ¹⁾ .. 1040 V _{rms} (max. overvoltage 1350 V _{rms})
Resolution	0.01 V
Crest factor	2.45 (related to the measuring range)
Impedance	3 M Ω /phase
Power consumption	approx. 0.1 VA
Sampling frequency	8.13 kHz
Frequency of the fundamental oscillation	45 Hz ... 65 Hz
- Resolution	0.01 Hz
Fourier analysis	1st - 40th harmonic

1) The device only determines measured values if a voltage L1-N of greater than 20 V_{rms} (4-conductor measurement) or a voltage L1-L2 of greater than ≈ 34 V_{rms} (3-conductor measurement) is applied to voltage measurement input V1.

CURRENT MEASUREMENT

Nominal current	5 A
Measuring range	0.005 .. 6 A _{rms}
Crest factor	2 (relative to 6 A _{rms})
Overvoltage category	300 V CAT II
Rated surge voltage	2.5 kV
Power consumption	approx. 0.2 VA (R _i =5 m Ω)
Overload for 1 s	60 A (sinusoidal)
Resolution	0.1 mA (display 0.01 A)
Sampling frequency	8.13 kHz
Fourier analysis	1st – 40th harmonic

SERIAL INTERFACE

RS-485 - Modbus RTU/Slave	9.6 kbps, 19.2 kbps, 38.4 kbps, 57.6 kbps, 115.2 kbps
---------------------------	---

DIGITAL OUTPUTS (3 digital outputs, solid state relays, not short-circuit proof)

Switching voltage	max. 33 V AC, 40 V DC
Switching current	max. 50 mA _{eff} AC/DC
Response time	approx. 200 ms
Pulse output	max. 50 Hz (energy pulses)

Digital output 1 (terminal 21/22) of the UMG 96-PA-MID+ provides the active energy (applied/delivered) measured value!

DIGITAL INPUTS (3 digital inputs, solid state relays, not short-circuit proof)

Maximum counter frequency	20 Hz
Input signal applied	18 V .. 28 V DC (typically 4 mA)
Input signal not applied	0 .. 5 V DC, current less than 0.5 mA

CABLE LENGTH (DIGITAL INPUTS/OUTPUTS)

Up to 30 m (32.81 yd)	Unshielded
Greater than 30 m (32.81 yd)	Shielded

ANALOG OUTPUTS

External power supply	max. 33 V
Current	0 ... 20 mA
Update time	1 s
Load	max. 300 Ω
Resolution	10 bit

CONNECTION CAPACITY OF THE TERMINALS (SUPPLY VOLTAGE)

Connectible conductors. Only connect one conductor per terminal!

Single core, multi-core, fine-stranded	0.2 – 4.0 mm ² , AWG 28-12
Wire ferrules (non-insulated)	0.2 – 2.5 mm ² , AWG 26-14
Wire ferrules (insulated)	0.2 – 2.5 mm ² , AWG 26-14
Tightening torque	0.4 – 0.5 Nm (3.54 – 4.43 lbf in)
Strip length	7 mm (0.2756 in)

CONNECTION CAPACITY OF THE TERMINALS (VOLTAGE MEASUREMENT)

Connectible conductors. Only connect one conductor per terminal!

Single core, multi-core, fine-stranded	0.2 – 4.0 mm ² , AWG 28-12
Wire ferrules (non-insulated)	0.2 – 2.5 mm ² , AWG 26-14
Wire ferrules (insulated)	0.2 – 2.5 mm ² , AWG 26-14
Tightening torque	0.4 – 0.5 Nm (3.54 – 4.43 lbf in)
Strip length	7 mm (0.2756 in)

CONNECTION CAPACITY OF THE TERMINALS (CURRENT MEASUREMENT)

Connectible conductors. Only connect one conductor per terminal!

Single core, multi-core, fine-stranded	0.2 – 4 mm ² , AWG 28-12
Wire ferrules (non-insulated)	0.2 – 2.5 mm ² , AWG 26-14
Wire ferrules (insulated)	0.2 – 2.5 mm ² , AWG 26-14
Tightening torque	0.4 – 0.5 Nm (3.54 – 4.43 lbf in)
Strip length	7 mm (0.2756 in)

TERMINAL CONNECTION CAPACITY (SERIAL INTERFACE)

Connectible conductors. Only connect one conductor per terminal!

Single core, multi-core, fine-stranded	0.2 – 1.5 mm ² , AWG 28-16
Wire ferrules (non-insulated)	0.2 – 1.5 mm ² , AWG 26-16
Wire ferrules (insulated)	0.2 – 1.5 mm ² , AWG 26-16
Tightening torque	0.2 – 0.25 Nm (1.77 – 2.21 lbf in)
Strip length	7 mm (0.2756 in)

CONNECTION CAPACITY OF THE TERMINALS (DIGITAL INPUTS/OUTPUTS, ANALOG OUTPUT)

Connectible conductors. Only connect one conductor per terminal!

Single core, multi-core, fine-stranded	0.2 – 1.5 mm ² , AWG 28-16
Wire ferrules (non-insulated)	0.2 – 1.5 mm ² , AWG 26-16
Wire ferrules (insulated)	0.2 – 1.5 mm ² , AWG 26-16
Tightening torque	0.2 – 0.25 Nm (1.77 – 2.21 lbf in)
Strip length	7 mm (0.2756 in)

TECHNICAL DATA FOR THE MID+ CERTIFIED METER

Voltage measurement	3 x 57.7/100 V ... 3 x 289/500 V ¹⁾
Current measurement (measuring range)	0.002 ... 6 A
Frequency range	45-65 Hz
Reference frequency	50 Hz
Accuracy class	B
Pulse valency S0 (pulse constant)	10,000 pulses/kWh ²⁾
Electromagnetic environmental conditions	Class E2 (MID 2014/32/EU)
Mechanical environmental conditions	Class M1 (MID 2014/32/EU)
Suitable grid systems	1p2w, 3p3w, 3p4w

1) The following applies for the UMG 96-PA-MID+ when measuring voltage using voltage transformers: Use calibrated/permissible voltage transformers for MID-compliant measurement (secondary: 3 x 57.7/100 V - 3 x 289/500 V).

2) The pulse valency S0 is automatically adapted to the voltage transformer ratio that has been set.
The momentary pulse valency S0 appears in the Active energy measuring display.

MODULAR EXPANSION FOR THE UMG 96-PA-MID+ METER

Module 96-PA-RCM-EL

- Ethernet interface
- 2 residual current inputs
- Temperature measurement
- 4th current input
- DC measurement



MODULE 96-PA-RCM-EL – MODULE CONNECTIONS

Front view

Rear view

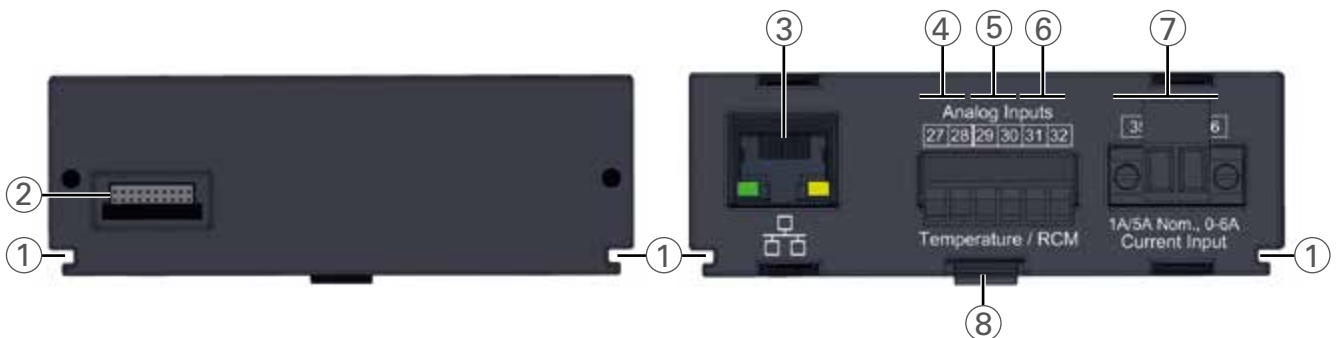

NO.	DESIGNATION	DESCRIPTION
1	Groove	Guide groove for the mounting/dismantling of the module
2	Module connector	Interface to basic device
3	RJ45	Only module 96-PA-RCM-EL: Ethernet interface (10/100Base-T)
4	Analog inputs - terminals 27 / 28	Temperature measurement
5	Analog inputs - terminals 29 / 30	Residual current measurement I5
6	Analog inputs - terminals 31 / 32	Residual current measurement I6 or voltage measurement U6 for the DC power
7	Current measurement input - terminals 35 / 36	Current measurement I4
8	Snapping mechanism	For mounting / removal of the module (snap in/snap out).

MODULE 96-PA-RCM-EL – CONNECTION EXAMPLE

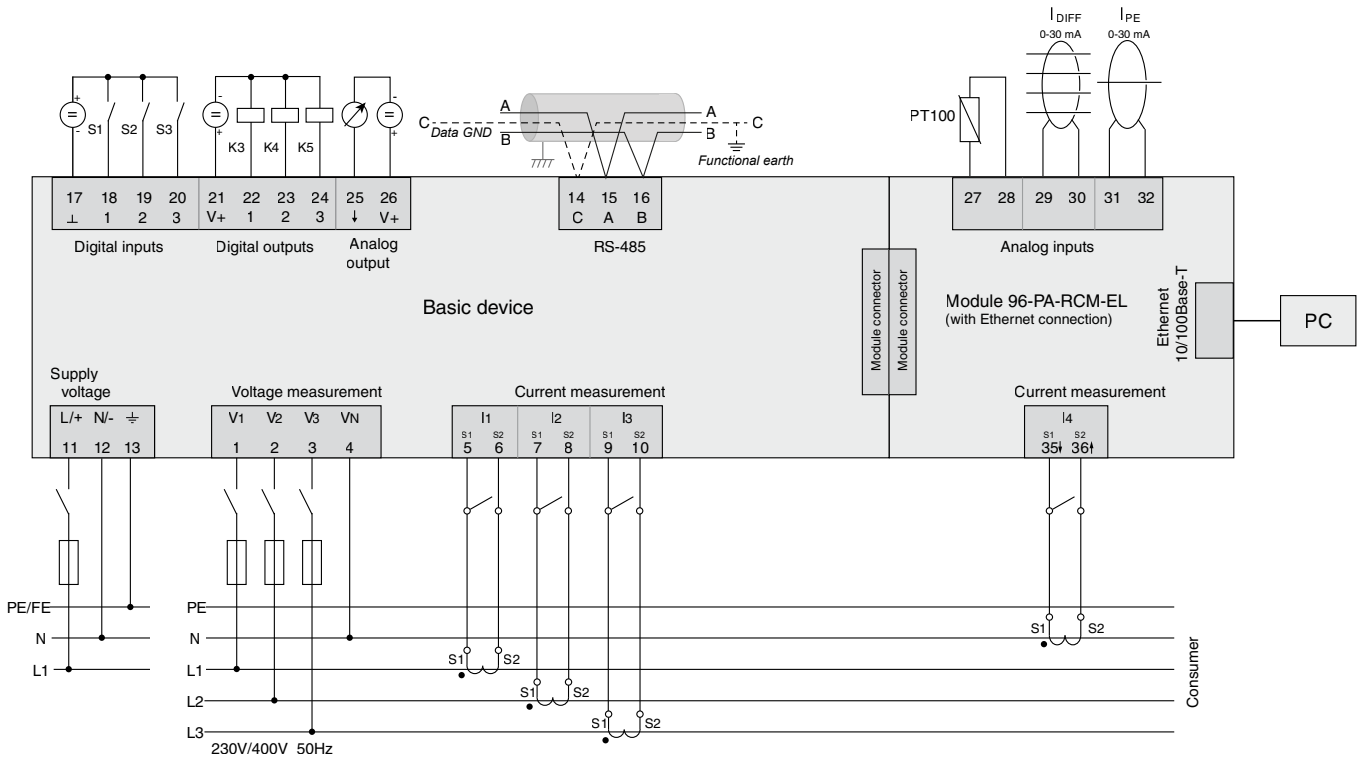

Fig.: Connection example "Basic device with module 96-PA-RCM-EL"
 Information on overcurrent devices can be found in the user manual of your basic device

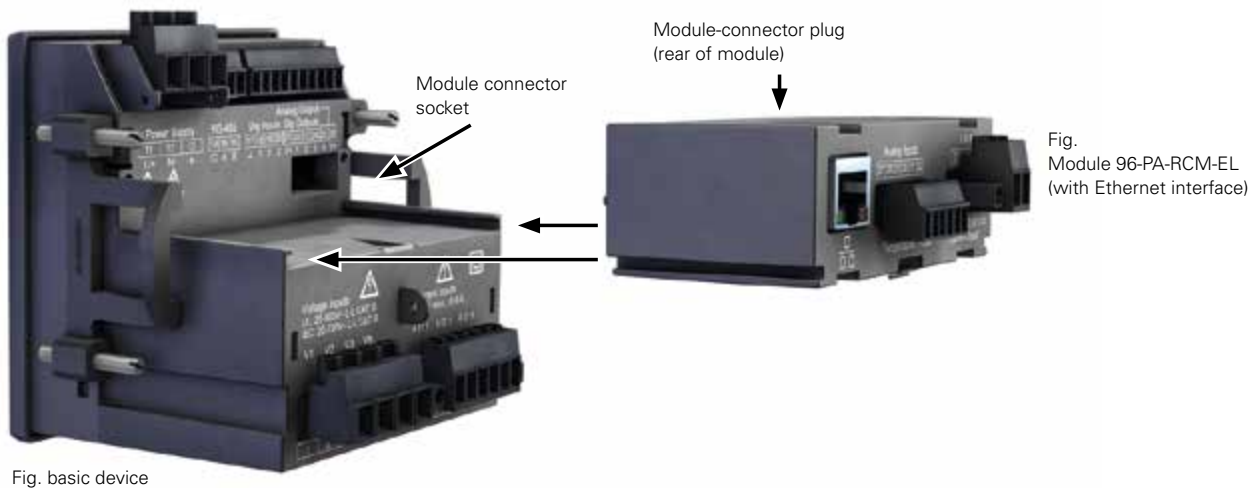

Fig. basic device

Fig. Module 96-PA-RCM-EL (with Ethernet interface)

MODULE 96-PA-RCM-EL – TECHNICAL DATA

MODULE 96-PA-RCM-EL WITH ETHERNET CONNECTION

PART NUMBER 5232010

GENERAL

Net weight of module (with attached plug-in connectors)	78 g (0.17 lbs)
Impact resistance	IK07 according to IEC 62262

TRANSPORT AND STORAGE

The following specifications apply for devices transported and stored in the original packaging.

Free fall	1 m (39.37 in)
Temperature	K55 –25 °C (–13 °F) to +70 °C (158 °F)
Relative air humidity (non-condensing)	0 to 90% RH

Environmental conditions during operation, see the usage information for your basic device.

ANALOG INPUTS

Differential or current signals	2x
Temperature measurement	1x

RESIDUAL CURRENT INPUT

Nominal current	30 mArms 0 ... 20 mA 4 ... 20 mA
Measuring range	0 ... 30 mArms
Operating current	50 µA
Resolution	1 µA
Cable break detection (failure monitoring)	Can be activated
Crest factor	1.414 (relative to 30 mA)
Load	4 Ω
Overload for 1 s	1 A
Constant overloaded	200 mA

According to IEC/TR 60755 (2008-01):

Measurement of residual currents

Type A



Type B and B+



TEMPERATURE MEASUREMENT

Update time	200 ms
Suitable thermal sensor	PT100, PT1000, KTY83, KTY84
Total burden (thermal sensor and lead)	max. 4 kΩ

THERMAL SENSOR TYPE	TEMPERATURE RANGE	RESISTANCE RANGE	MEASUREMENT UNCERTAINTY
PT100	–99 °C (–146.2 °F) ... +500 °C (932 °F)	60 Ω ... 180 Ω	±1.5% rng
PT1000	–99 °C (–146.2 °F) ... +500 °C (932 °F)	600 Ω ... 1.8 kΩ	±1.5% rng
KTY83	–55 °C (–67 °F) ... +175 °C (347 °F)	500 Ω ... 2.6 kΩ	±1.5% rng
KTY84	–40 °C (–40 °F) ... +300 °C (572 °F)	350 Ω ... 2.6 kΩ	±1.5% rng

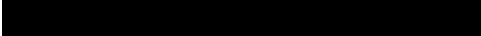

MULTIFUNCTIONAL POWER ANALYZER

(WITH ETHERNET AND RCM)

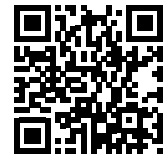

RESIDUAL CURRENT MONITORING

- Continuous monitoring of residual currents
- Alternative for insulation measurement in TN-S systems

INTERFACES

- RS-485
- Ethernet

POWER QUALITY

- Harmonics up to the 40th harmonic
- Rotating field components
- Distortion factor THD-U/THD-I

COMMUNICATION

- Modbus RTU, TCP, Gateway
- TCP/IP
- HTTP
- FTP
- SNMP
- NTP time synchronization
- SMTP
- DHCP
- SNTP
- TFTP
- BACnet (optional)

MEASURING ACCURACY

- Class 0.2S
- Current 0.2%
- Voltage 0.2%

MEASUREMENT DATA MEMORY

- 256 MB / partition A: approx. 106 months, partition B: approx. 26 months (according to factory setting)

PERIPHERALS

- 2 digital outputs
- 2 analog inputs
- 3 digital inputs or outputs (selectable)
- Temperature measurement input

UMG 96RM-E

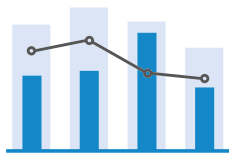

ENERGY MANAGEMENT

Extensive energy measurement data, high accuracy: 0.5S active energy

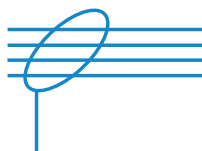

RCM

Integrated residual current measurement with dynamic limit value definition

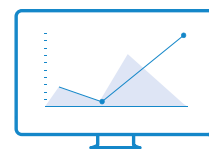

DISPLAY

Simple 2-button operation, LED backlight

UMG 96RM-E – DIMENSIONED DRAWING

All dimensions in mm

Side view

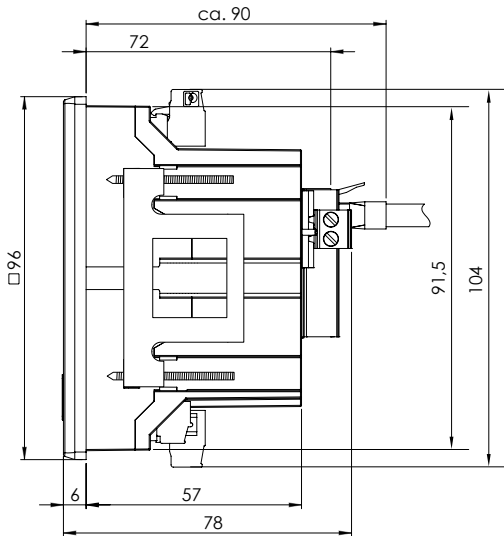

Rear view

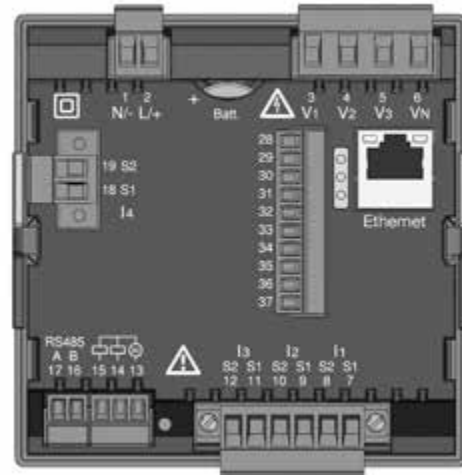

Cutout dimensions: $92^{+0.8} \times 92^{+0.8}$ mm

UMG 96RM-E – CONNECTION EXAMPLE

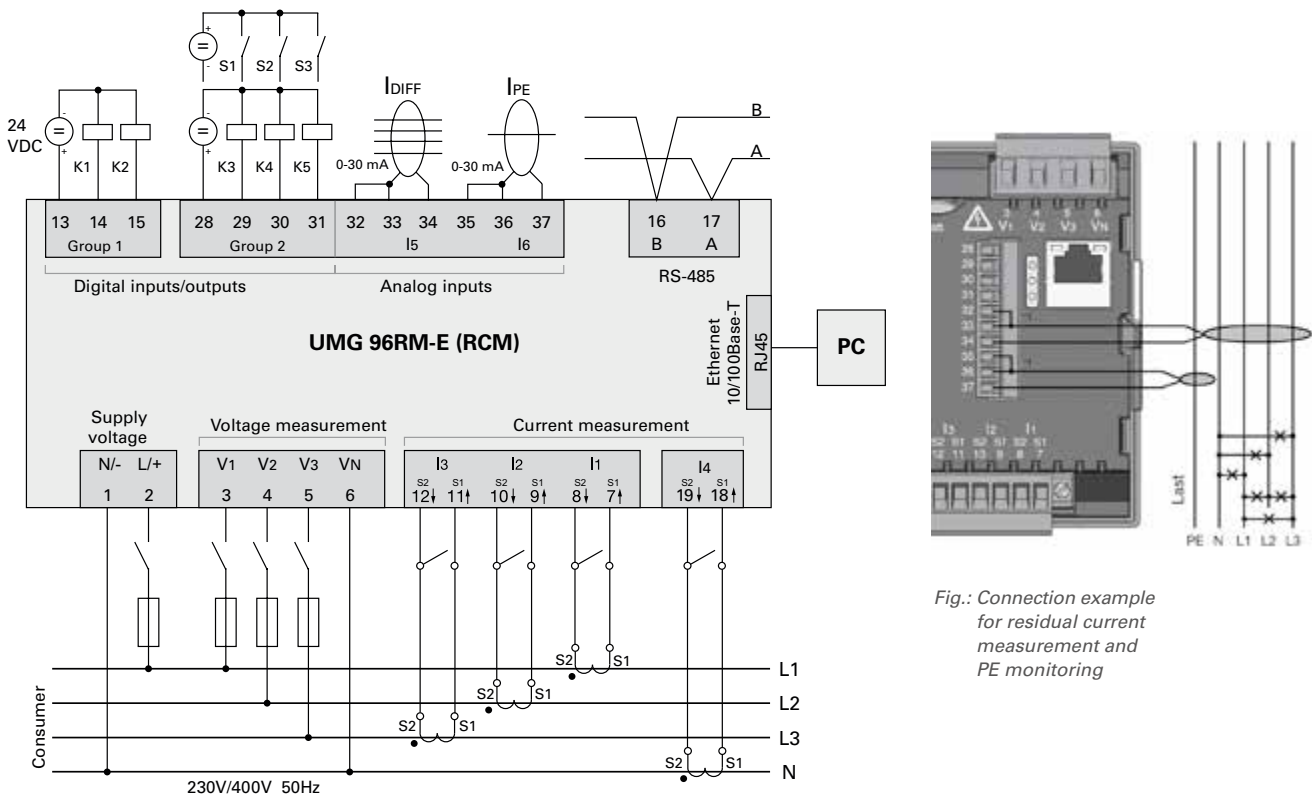
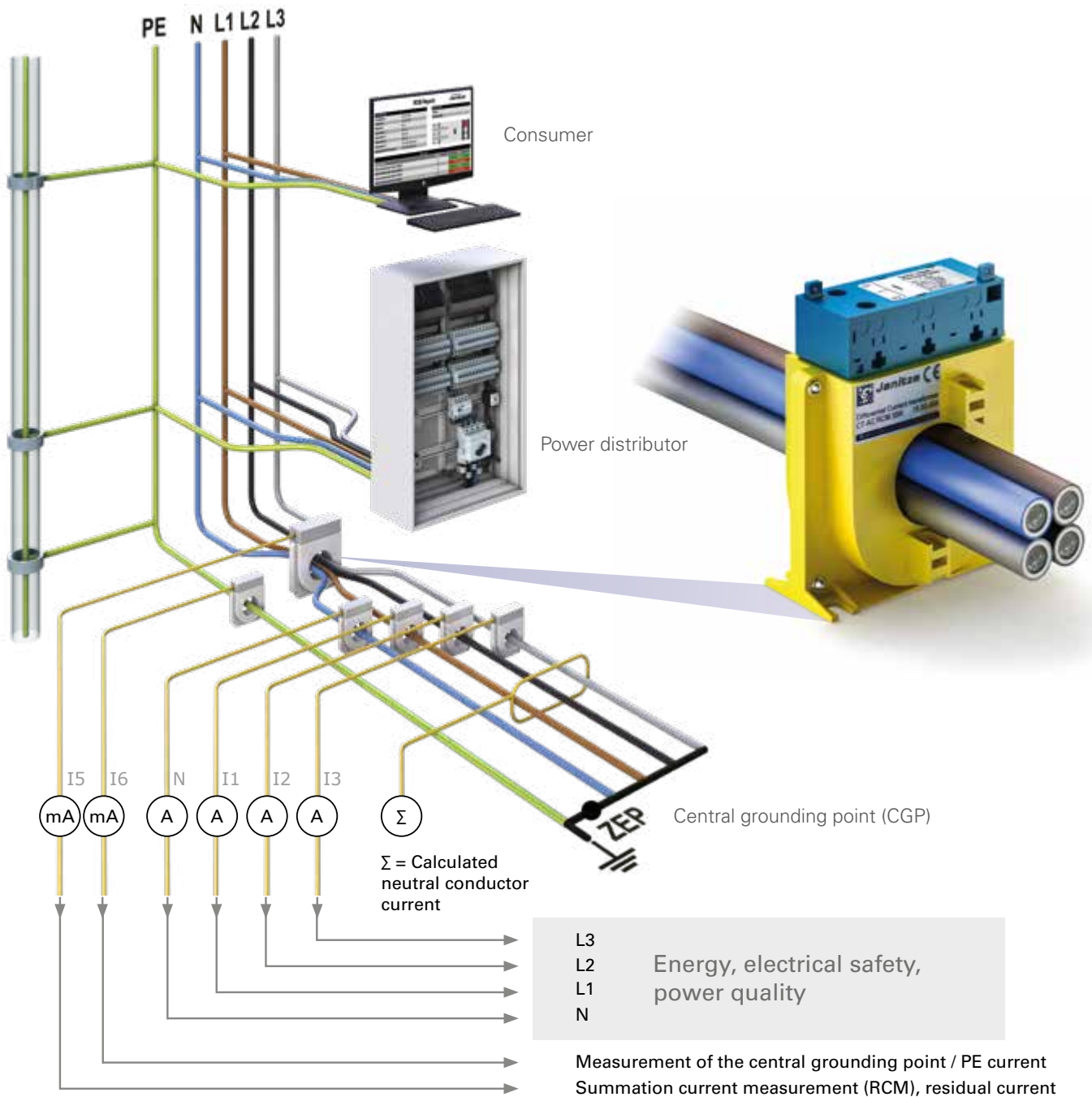

Fig.: Connection example for residual current measurement and PE monitoring

Fig.: Connection example with temperature and residual current measurement



Residual and operating current monitoring: Can be implemented with the UMG 512-PRO / UMG 509-PRO / UMG 96RM-E and UMG 96-PA network analyzers (with RCM module). The RCM device used should be easy to handle, automatically point out problems and at the same time provide valuable assistance to the service technician.

UMG 96RM-E – TECHNICAL DATA

UMG 96RM-E	
PART NUMBER (90–277 VAC / 90–250 VDC)	5222062
PART NUMBER (24–90 VAC / 24–90 VDC)	5222063
BACNET COMMUNICATION	5222081
GENERAL	
Net weight (with attached plug-in connectors)	approx. 370 g (0.82 lbs)
Package weight (incl. accessories)	approx. 950 g (2.09 lbs)
Battery	Type Lithium CR2032, 3 V, (UL 1642 approved)
Backlight service life	40000 h (backlight reduces to approx. 50% over this period)
TRANSPORT AND STORAGE	
The following information applies to devices that are transported or stored in their original packaging.	
Free fall	1m
Temperature	K55 (-25 °C to +70 °C) (-13 °F ..to 158 °F)
Relative humidity	0 to 90% RH
ENVIRONMENTAL CONDITIONS DURING OPERATION	
The UMG 96RM is intended for weather-protected, stationary use. Protection class II according to IEC 60536 (VDE 0106, Part 1).	
Rated temperature range	K55 (-10 °C ... +55 °C) (14 °F ..to 131 °F)
Relative humidity	0 to 75% RH
Operating elevation	0 ... 2000 m above sea level
Pollution degree	2
Mounting orientation	vertical
Ventilation	forced ventilation is not required.
Protection against foreign matter and water	
– Front	IP40 according to EN60529
– Rear	IP20 according to EN60529
– Front with seal	IP54 according to EN60529
SUPPLY VOLTAGE	
Option 230 V	
Nominal range	90 V – 277 V (50/60 Hz) or DC 90 V – 250 V; 300 V CAT III
Power consumption	max. 7.5 VA / 4 W
Option 24 V	
Nominal range	24 V - 90 V AC / DC; 150 V CAT III
Power consumption	max. 7.5 VA / 5 W
Operating range	±10% of nominal range
Internal fuse, not replaceable	Type T1A / 250 V/277 V according to IEC 60127
Recommended overcurrent protective device for the line protection (UL approval)	Option 230 V: 6 – 16 A Option 24 V: 1 – 6 A (Char. B)
<i>Recommendation for the maximum number of devices on a line circuit breaker: Option 230 V: Line circuit breaker B6A: max. 4 devices / line circuit breaker B16A: max. 11 devices Option 24 V: Line circuit breaker B6A: max. 3 devices / line circuit breaker B16A: max. 9 devices</i>	
DIGITAL OUTPUTS	
2 and optionally additional 3 digital outputs, solid state relay, not short-circuit proof.	
Switching voltage	max. 33 VAC, 60 VDC
Switching current	max. 50 mAeff AC/DC
Response time	10/12 periods + 10 ms *
Digital output (energy pulses)	max. 50 Hz

* Response time e.g. at 50 Hz: 200 ms + 10 ms = 210 ms

DIGITAL INPUTS

Optionally, 3 digital inputs, solid state relays, not short-circuit proof.

Maximum counter frequency	20 Hz
Input signal applied	18 V ... 28 V DC (typically 4 mA)
Input signal not applied	0 ... 5 V DC, current less than 0.5 mA

TEMPERATURE MEASUREMENT INPUT

Optionally, 2 inputs

Update time	1 second
Connectible sensors	PT100, PT1000, KTY83, KTY84
Total load (sensor and cable)	max. 4 k Ω

SENSOR TYPE	TEMPERATURE RANGE	RESISTANCE RANGE	MEASUREMENT UNCERTAINTY
KTY83	-55° C ... +175° C (-67 °F ..to 347 °F)	500 ohms ... 2.6 k Ω	±1.5% rng
KTY84	-40° C ... +300° C (-40 °F ..to 572 °F)	350 ohms ... 2.6 k Ω	±1.5% rng
PT100	-99° C ... +500° C (-146.2 °F ..to 932 °F)	60 ohms ... 180 ohms	±1.5% rng
PT1000	-99° C ... +500° C (-146.2 °F ..to 932 °F)	600 ohms ... 1.8 k Ω	±1.5% rng

CABLE LENGTH (DIGITAL INPUTS/OUTPUTS, TEMPERATURE MEASUREMENT INPUT)

Up to 30 m	Unshielded
Greater than 30 m	Shielded

SERIAL INTERFACE

RS-485 Modbus RTU/Slave	9.6 kbps, 19.2 kbps, 38.4 kbps, 57.6 kbps, 115.2 kbps
Strip length	7 mm

VOLTAGE MEASUREMENT

Three-phase 4-conductor systems with rated voltages up to	277 V/480 V ($\pm 10\%$)
Three-phase 3-conductor systems, non-grounded, with rated voltages up to	IT 480V ($\pm 10\%$)
Overvoltage category	300 V CAT III
Rated surge voltage	4 kV
Measuring range L-N	0 ¹⁾ ... 300 Vrms (max. overvoltage 520 Vrms)
Measuring range L-L	0 ¹⁾ ... 520 Vrms (max. overvoltage 900 Vrms)
Resolution	0.01 V
Crest factor	2.45 (related to the measuring range)
Impedance	3 M Ω /phase
Power consumption	approx. 0.1 VA
Sampling frequency	21.33 kHz (50 Hz), 25.6 kHz (60 Hz) per measurement channel
Frequency of the fundamental oscillation	45 Hz ... 65 Hz
- Resolution	0.01 Hz

¹⁾ The UMG 96RM-E can only determine measured values if a voltage L1-N of greater than 20 Vrms (4-wire measurement) or a voltage L1-L2 of greater than 34 Vrms (3-wire measurement) is present at the voltage measurement input V1.

CURRENT MEASUREMENTS I1-I4

Nominal current	5 A
Measuring range	0 ... 6 Arms
Crest factor	1.98
Resolution	0.1 mA (display 0.01 A)
Overvoltage category	300 V CAT II
Rated surge voltage	2 kV
Power consumption	approx. 0.2 VA (Ri = 5 m Ω)
Overload for 1 s	120 A (sinusoidal)
Sampling frequency	20 kHz

RESIDUAL CURRENT MEASUREMENT I5 / I6

Nominal current	30 mA _{rms}
Measuring range	0 ... 40 mA _{rms}
Operating current	50 µA
Resolution	1 µA
Crest factor	1.414 (relative to 40 mA)
Load	4 Ω
Overload for 1 s	5 A
Constant overloaded	1 A
Overload 20 ms	50 A

According to IEC/TR 60755 (2008-01):

Measurement of residual currents

type A 

type B 

ETHERNET PORT

Connection	RJ45
Functions	Modbus gateway, embedded web server (HTTP)
Protocols	TCP/IP, DHCP client (BootP), Modbus/TCP (port 502), ICMP (Ping), NTP, Modbus RTU over Ethernet (Port 8000), FTP, SNMP

CONNECTION CAPACITY OF THE TERMINALS (SUPPLY VOLTAGE)

Connectible conductors. Only one conductor may be connected per terminal!

Single core, multi-core, fine-stranded	0.2–2.5 mm ² , AWG 26-12
Terminal pins, wire ferrules	0.2–2.5 mm ²
Tightening torque	0.4–0.5 Nm (3.54–4.43 lbf in)
Strip length	7 mm (0.2756 in)

CONNECTION CAPACITY OF THE TERMINALS (VOLTAGE AND CURRENT MEASUREMENT)

Connectible conductors. Only one conductor may be connected per terminal!

	Current	Voltage
Single core, multi-core, fine-stranded	0.2 – 2.5 mm ² , AWG 26-12	0.08 – 4.0 mm ² , AWG 28-12
Terminal pins, wire ferrules	0.2 – 2.5 mm ²	0.2 – 2.5 mm ²
Tightening torque	0.4 – 0.5 Nm (3.54 – 4.43 lbf in)	0.4 – 0.5 Nm (3.54 – 4.43 lbf in)
Strip length	7 mm (0.2756 in)	7 mm (0.2756 in)

TERMINAL CONNECTION CAPACITY

(residual current or temperature measurement inputs and digital inputs/outputs)

Rigid/flexible	0.14 – 1.5 mm ² , AWG 28-16
Flexible with wire ferrules without plastic sleeve	0.20–1.5 mm ²
Flexible with wire ferrules with plastic sleeve	0.20–1.5 mm ²
Tightening torque	0.20–0.25 Nm (1.77–2.21 lbf in)

TERMINAL CONNECTION CAPACITY (SERIAL INTERFACE)

Single core, multi-core, fine-stranded	0.20–1.5 mm ²
Terminal pins, wire ferrules	0.20–1.5 mm ²
Tightening torque	0.20–0.25 Nm (1.77–2.21 lbf in)
Strip length	7 mm (0.2756 in)

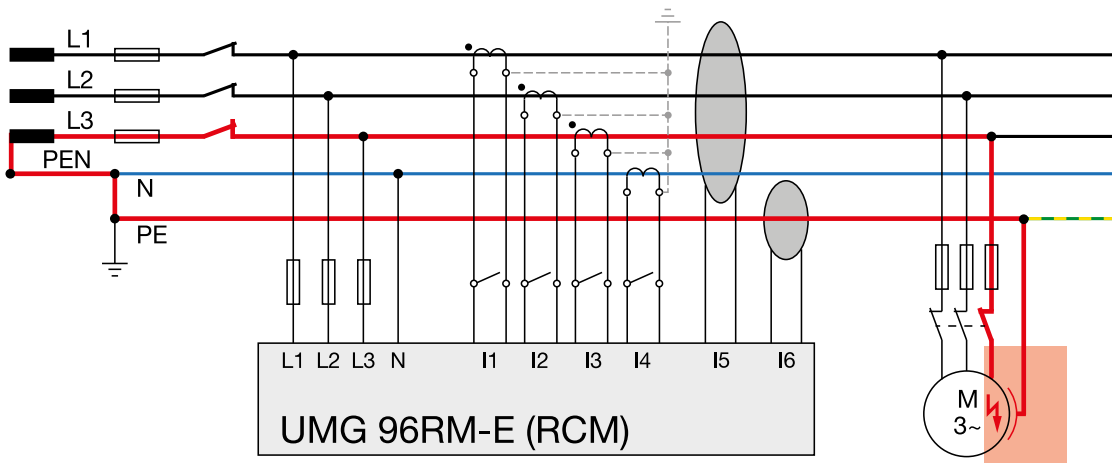

Fig.: UMG 96RM-E with residual current monitoring via measuring inputs I5 / I6

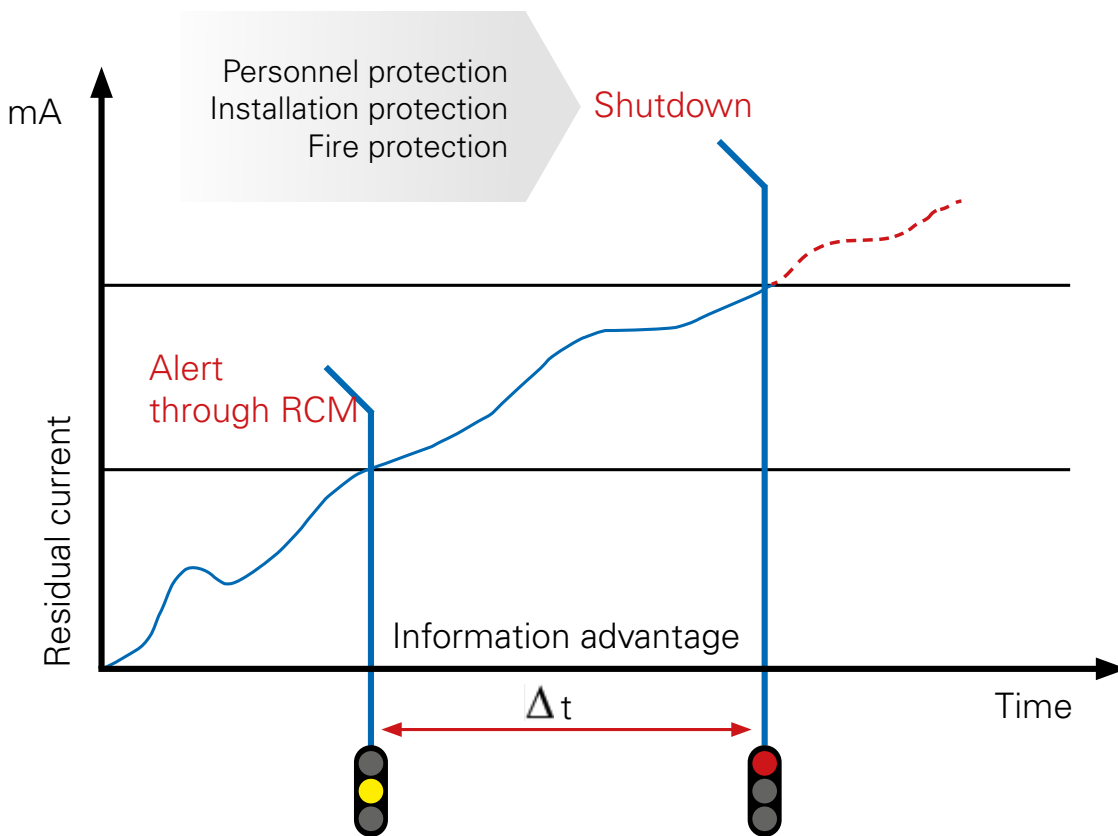

Fig.: Alert before switching off – An objective of residual current monitoring

MODULARLY EXPANDABLE NETWORK ANALYZER



POWER QUALITY

- Harmonics up to the 65th harmonic
- Distortion factor THD-U/THD-I
- Sampling frequency: 13.67 kHz
- Full-wave events
- Analysis option on the display
- Directional drag indicator
- 20 ms RMS value memory

MODULARITY

- Temperature measurement with monitoring via integrated comparator
- Ethernet interface with Modbus TCP and gateway function
- 2 residual current inputs
- Neutral conductor measurement (I4 – current measurement)

INTERFACES

- RS-485

COMMUNICATION

- Modbus RTU

MEASUREMENT DATA MEMORY

- 64 MB / partition A: approx. 45 months, partition B: approx. 20 months (according to factory setting)

MEASURING ACCURACY

- Class 0.2S
- Current: 0.2%
- Voltage: 0.2%

PERIPHERALS

- 3 digital inputs and outputs
- 1 analog output

COLOR GRAPHIC DISPLAY

- 6-button operation
- Measured values numerically, as diagram or graph
- Intuitive operation

SOFTWARE ACTIVATION

- According to IEC 61000-4-30 Class S
- Recording according to EN 50160
- Flicker
- Fast voltage change
- Interharmonics

UMG 96-PQ-L



OPERATING CONVENIENCE

Clear presentation of all relevant measured values on the display

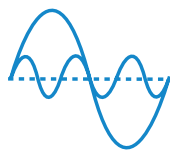

POWER QUALITY

Threshold monitoring and measurement up to the 65th harmonic

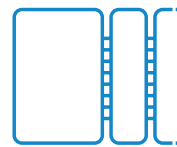

MODULAR

Future-proof thanks to retrofittable modules and firmware packages

UMG 96-PQ-L – DIMENSIONED DRAWING

All dimensions in mm

Side view

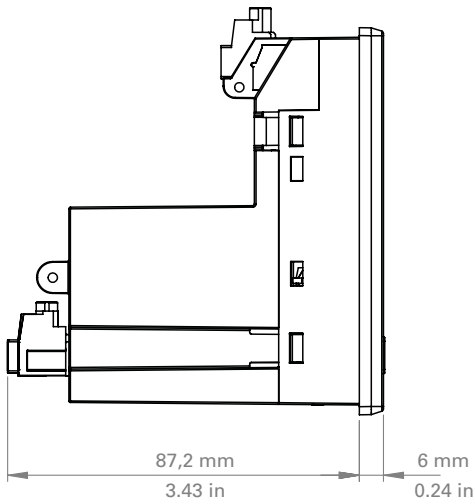

Bottom view

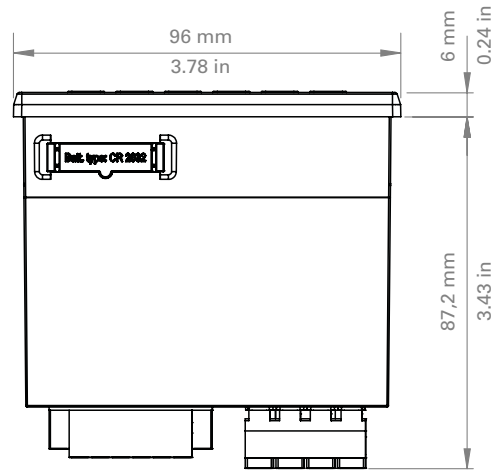

Cutout dimensions: 92^{+0,8} x 92^{+0,8} mm

UMG 96-PQ-L – CONNECTION EXAMPLE

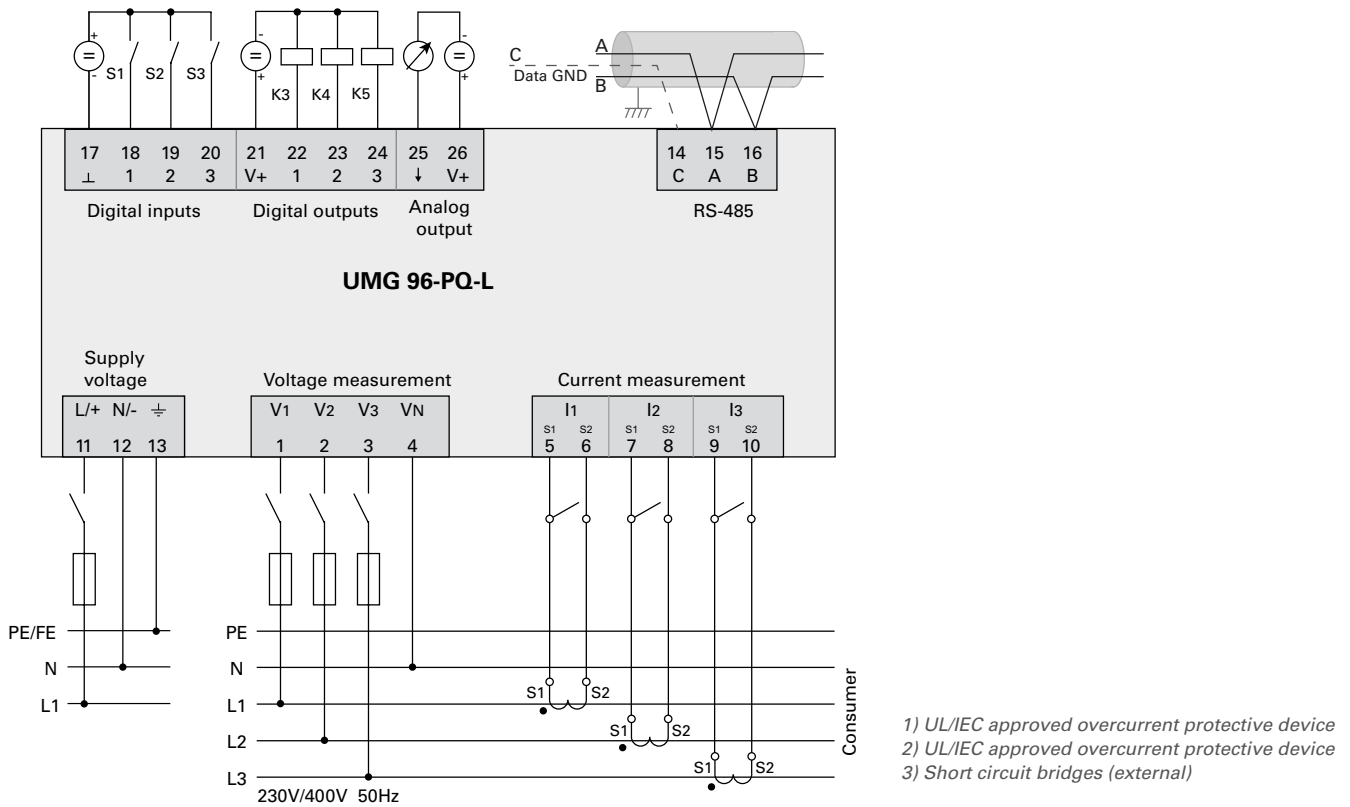

UMG 96-PQ-L – TECHNICAL DATA

UMG 96-PQ-L	SUPPLY VOLTAGE	NETWORK CONFIGURATION	IEC 61000-4-30	PART NUMBER
UMG 96-PQ-L	90–277 VAC / 90–250 VDC	TN- AND TT	*	5236001
UMG 96-PQ-L	24–90 VAC / 24–90 VDC	TN- AND TT	*	5236002
UMG 96-PQ-L	90–277 VAC / 90–250 VDC	TN-, TT- AND IT	*	5236005
UMG 96-PQ-L	90–277 VAC / 90–250 VDC	TN- AND TT	CLASS S	5236021
UMG 96-PQ-L	24–90 VAC / 24–90 VDC	TN- AND TT	CLASS S	5236022
UMG 96-PQ-L	90–277 VAC / 90–250 VDC	TN-, TT- AND IT	CLASS S	5236025
* SOFTWARE ACTIVATION (ON IEC 61000-4-30 CLASS S) FOR PART NO. 5236001, 5236002, 5236005				5236020

GENERAL

Net weight (with attached plug-in connectors)	approx. 250 g (0.55 lbs)
Package weight (incl. accessories)	approx. 500 g (1.1 lbs)
Battery	Type Lithium CR2032, 3 V, (UL 1642 approved)
Data memory	64 MB
Backlight service life	40000 h (backlight reduces to approx. 50% over this period)
Impact resistance	IK07 according to IEC 62262

TRANSPORT AND STORAGE

The following information applies to devices that are transported or stored in their original packaging.

Free fall	1 m (39.37 in)
Temperature	–25 °C (–13 °F) to +70 °C (158 °F)
Relative air humidity (non-condensing)	0 to 90% RH

ENVIRONMENTAL CONDITIONS DURING OPERATION

Install the device in a weather-protected and stationary location.
Protection class II according to IEC 60536 (VDE 0106, Part 1).

Rated temperature range	–10 °C (14 °F) ... +55 °C (131 °F)
Relative air humidity (non-condensing)	0 to 75% RH
Operating elevation	0 ... 2000 m (6562 ft) above sea level
Pollution degree	2
Mounting orientation	As desired
Ventilation	No forced ventilation required.
Protection against foreign matter and water	
– Front	IP40 according to EN60529
– Rear	IP20 according to EN60529
– Front with seal	IP54 according to EN60529

SUPPLY VOLTAGE

Option 230 V:	
Nominal range	AC 90 V – 277 V (50/60 Hz) or DC 90 V – 250 V, 300 V CATIII
Power consumption	max. 4.5 VA / 2 W
Option 24 V:	
Nominal range	AC 24 V – 90 V (50/60Hz) or DC 24 V – 90 V, 150 V CATIII
Power consumption	max. 4.5 VA / 2 W
Operating range	±10% of nominal range
Internal fuse, not replaceable	Type T1A / 250 V DC / 277 V AC according to IEC 60127
Recommended overcurrent protective device for the line protection (UL approval)	Option 230 V: 6 – 16 A (Char. B) Option 24 V: 1 – 6 A (Char. B)

Recommendation for the maximum number of devices on a line circuit breaker:

Option 230 V: Line circuit breaker B6A: max. 4 devices / line circuit breaker B16A: max. 11 devices

Option 24 V: Line circuit breaker B6A: max. 3 devices / line circuit breaker B16A: max. 9 devices

VOLTAGE MEASUREMENT

Three-phase 4-conductor systems with rated voltages up to	417 V / 720 V ($\pm 10\%$) according to IEC 347 V / 600 V ($\pm 10\%$) according to UL
Three-phase 3-conductor systems with rated voltages up to	600 V ($\pm 10\%$)
Single-phase 2-conductor system with rated voltages up to	480 V ($\pm 10\%$)
Overtoltage category	600 V CAT III
Rated surge voltage	6 kV
Protection of the voltage measurement	1 – 10 A (with IEC/UL approval)
Measuring range L-N	0 ¹⁾ ... 600 Vrms (max. overvoltage 800 Vrms)
Measuring range L-L	0 ¹⁾ ... 1040 Vrms (max. overvoltage 1350 Vrms)
Resolution	0.01 V
Crest factor	2.45 (related to the measuring range)
Impedance	3 M Ω /phase
Power consumption	approx. 0.1 VA
Sampling frequency	13.67 kHz
Frequency of the fundamental oscillation – Resolution	45 Hz ... 65 Hz 0.01 Hz
Fourier analysis	1st – 65th harmonic

The device only determines measured values if a voltage L1-N of greater than 20 Vrms (4-conductor measurement) or a voltage L1-L2 of greater than 34 Vrms (3-conductor measurement) is applied to voltage measurement input V1.

CURRENT MEASUREMENT

Nominal current	5 A
Measuring range	0.005 ... 6 Arms
Crest factor	2 (relative to 6 Arms)
Overtoltage category	300 V CAT II
Rated surge voltage	2 kV
Power consumption	approx. 0.2 VA (Ri=5 m Ω)
Overload for 1 s	60 A (sinusoidal)
Resolution	0.1 mA (display 0.01 A)
Sampling frequency	13.67 kHz
Fourier analysis	1st – 65th harmonic

SERIAL INTERFACE

RS-485–Modbus RTU/Slave	9.6 kbps, 19.2 kbps, 38.4 kbps, 57.6 kbps, 115.2 kbps
-------------------------	---

DIGITAL OUTPUTS

3 digital outputs, solid state relays, not short-circuit proof.

Switching voltage	max. 33 V AC, 40 V DC
Switching current	max. 50 mAeff AC/DC
Response time	approx. 200 ms
Pulse output	max. 50 Hz (energy pulses)

DIGITAL INPUTS

3 digital inputs, solid state relays, not short-circuit proof.

Maximum counter frequency	20 Hz
Input signal applied	18 V ... 28 V DC (typically 4 mA)
Input signal not applied	0 ... 5 V DC, current less than 0.5 mA

CABLE LENGTH (DIGITAL INPUTS/OUTPUTS)

Up to 30 m (32.81 yd)	Unshielded
Greater than 30 m (32.81 yd)	Shielded

ANALOG OUTPUTS

External power supply	max. 33 V
Current	0 ... 20 mA
Update time	1 s
Load	max. 300 Ω
Resolution	10 bit

CONNECTION CAPACITY OF THE TERMINALS (SUPPLY VOLTAGE)

Connectible conductors. Only connect one conductor per terminal!

Single core, multi-core, fine-stranded	0.2–4.0 mm ² , AWG 28-12
Wire ferrules (non-insulated)	0.2–2.5 mm ² , AWG 26-14
Wire ferrules (insulated)	0.2–2.5 mm ² , AWG 26-14
Tightening torque	0.4–0.5 Nm (3.54–4.43 lbf in)
Strip length	7 mm (0.2756 in)

CONNECTION CAPACITY OF THE TERMINALS (VOLTAGE MEASUREMENT)

Connectible conductors. Only connect one conductor per terminal!

Single core, multi-core, fine-stranded	0.2–4.0 mm ² , AWG 28-12
Wire ferrules (non-insulated)	0.2–2.5 mm ² , AWG 26-14
Wire ferrules (insulated)	0.2–2.5 mm ² , AWG 26-14
Tightening torque	0.4–0.5 Nm (3.54–4.43 lbf in)
Strip length	7 mm (0.2756 in)

CONNECTION CAPACITY OF THE TERMINALS (CURRENT MEASUREMENT)

Connectible conductors. Only connect one conductor per terminal!

Single core, multi-core, fine-stranded	0.2–4 mm ² , AWG 28-12
Wire ferrules (non-insulated)	0.2–4 mm ² , AWG 26-12
Wire ferrules (insulated)	0.2–2.5 mm ² , AWG 26-14
Tightening torque	0.4–0.5 Nm (3.54–4.43 lbf in)
Strip length	7 mm (0.2756 in)

TERMINAL CONNECTION CAPACITY (SERIAL INTERFACE)

Connectible conductors. Only connect one conductor per terminal!

Single core, multi-core, fine-stranded	0.2–1.5 mm ² , AWG 28-16
Wire ferrules (non-insulated)	0.2–1.5 mm ² , AWG 26-16
Wire ferrules (insulated)	0.2–1.5 mm ² , AWG 26-16
Tightening torque	0.2–0.25 Nm (1.77–2.21 lbf in)
Strip length	7 mm (0.2756 in)

CONNECTION CAPACITY OF THE TERMINALS (DIGITAL INPUTS/OUTPUTS, ANALOG OUTPUT)

Connectible conductors. Only connect one conductor per terminal!

Single core, multi-core, fine-stranded	0.2–1.5 mm ² , AWG 28-16
Wire ferrules (non-insulated)	0.2–1.5 mm ² , AWG 26-16
Wire ferrules (insulated)	0.2–1.5 mm ² , AWG 26-16
Tightening torque	0.2–0.25 Nm (1.77–2.21 lbf in)
Strip length	7 mm (0.2756 in)

MODULAR EXPANSION FOR THE UMG 96-PQ-L METER

Module 96-PA-RCM-EL

- Ethernet interface
- 2 residual current inputs
- Temperature measurement
- 4th current input
- DC measurement



MODULE 96-PA-RCM-EL – MODULE CONNECTIONS

Front view

Rear view

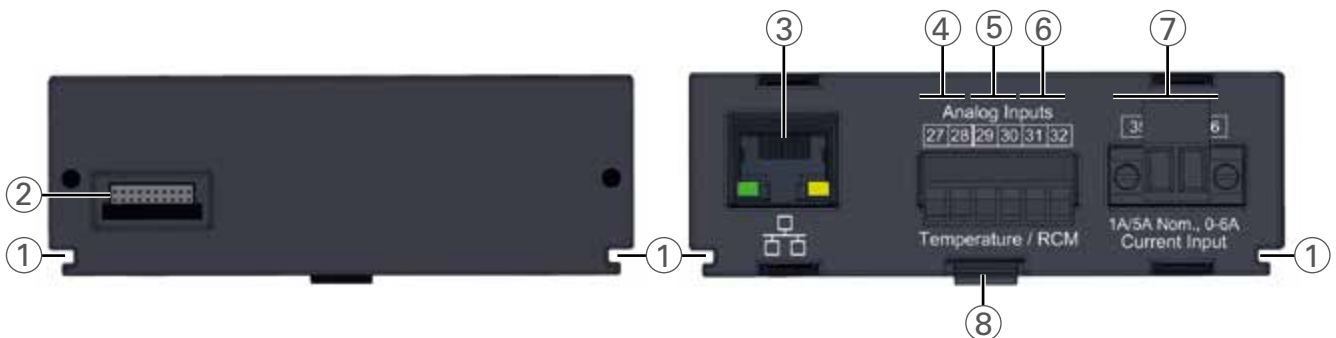

NO.	DESIGNATION	DESCRIPTION
1	Groove	Guide groove for the mounting/dismantling of the module
2	Module connector	Interface to basic device
3	RJ45	Only module 96-PA-RCM-EL: Ethernet interface (10/100Base-T)
4	Analog inputs - terminals 27 / 28	Temperature measurement
5	Analog inputs - terminals 29 / 30	Residual current measurement I5
6	Analog inputs - terminals 31 / 32	Residual current measurement I6 or voltage measurement U6 for the DC power
7	Current measurement input - terminals 35 / 36	Current measurement I4
8	Snapping mechanism	For mounting/removal of the module (snap in/snap out).

MODULE 96-PA-RCM-EL – CONNECTION EXAMPLE

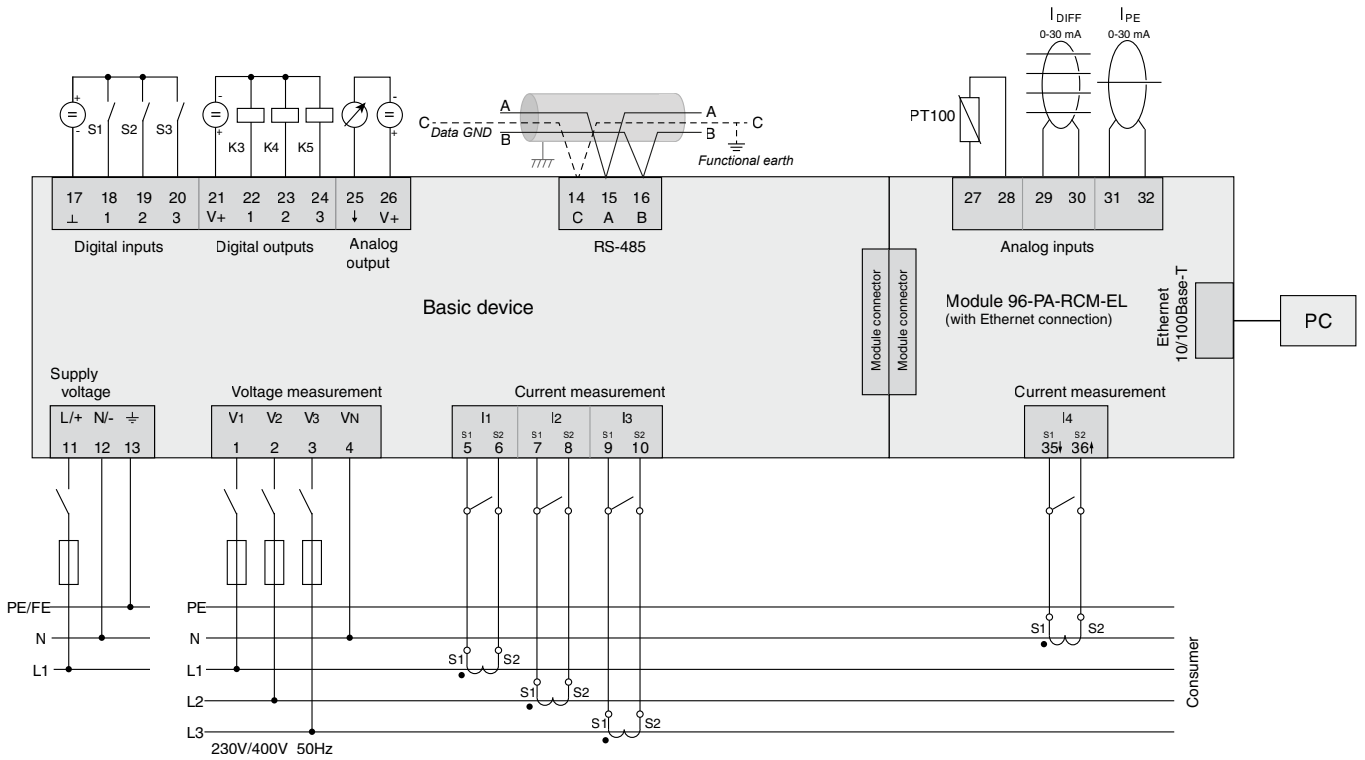

Fig.: Connection example "Basic device with module 96-PA-RCM-EL"
 Information on overcurrent devices can be found in the user manual of your basic device

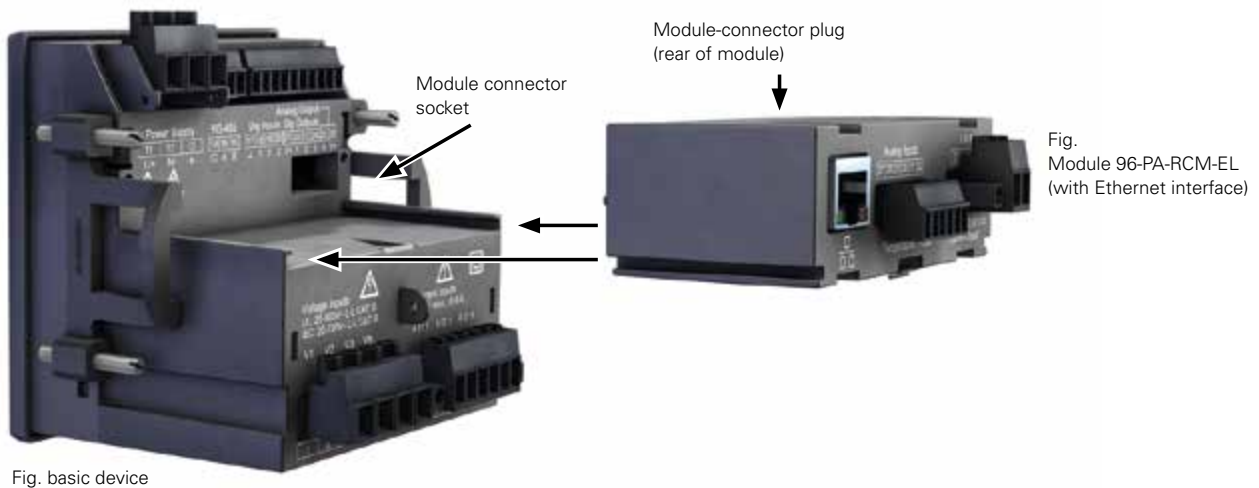

Fig. basic device

Fig. Module 96-PA-RCM-EL (with Ethernet interface)

MODULE 96-PA-RCM-EL – TECHNICAL DATA

MODULE 96-PA-RCM-EL WITH ETHERNET CONNECTION

PART NUMBER 5232010

GENERAL

Net weight of module (with attached plug-in connectors)	78 g (0.17 lbs)
Impact resistance	IK07 according to IEC 62262

TRANSPORT AND STORAGE

The following specifications apply for devices transported and stored in the original packaging.

Free fall	1 m (39.37 in)
Temperature	K55 –25 °C (–13 °F) to +70 °C (158 °F)
Relative air humidity (non-condensing)	0 to 90% RH

Environmental conditions during operation, see the usage information for your basic device.

ANALOG INPUTS

Differential or current signals	2x
Temperature measurement	1x

RESIDUAL CURRENT INPUT

Nominal current	30 mArms 0 ... 20 mA 4 ... 20 mA
Measuring range	0 ... 30 mArms
Operating current	50 µA
Resolution	1 µA
Cable break detection (failure monitoring)	Can be activated
Crest factor	1.414 (relative to 30 mA)
Load	4 Ω
Overload for 1 s	1 A
Constant overloaded	200 mA

According to IEC/TR 60755 (2008-01):

Measurement of residual currents

Type A



Type B and B+



TEMPERATURE MEASUREMENT

Update time	200 ms
Suitable thermal sensor	PT100, PT1000, KTY83, KTY84
Total burden (thermal sensor and lead)	max. 4 kΩ

THERMAL SENSOR TYPE	TEMPERATURE RANGE	RESISTANCE RANGE	MEASUREMENT UNCERTAINTY
PT100	–99 °C (–146.2 °F) ... +500 °C (932 °F)	60 Ω ... 180 Ω	±1.5% rng
PT1000	–99 °C (–146.2 °F) ... +500 °C (932 °F)	600 Ω ... 1.8 kΩ	±1.5% rng
KTY83	–55 °C (–67 °F) ... +175 °C (347 °F)	500 Ω ... 2.6 kΩ	±1.5% rng
KTY84	–40 °C (–40 °F) ... +300 °C (572 °F)	350 Ω ... 2.6 kΩ	±1.5% rng



MULTIFUNCTIONAL POWER QUALITY ANALYZER

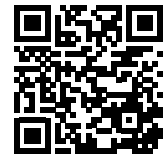

MEASURING ACCURACY

- Class 0.2S
- Current: 0.2%
- Voltage: 0.1%

POWER QUALITY

- Harmonics current up to the 63rd harmonic
- Power quality analysis onboard
- Events and transients
- Unbalance

INTERFACES

- Ethernet
- Profibus (DSUB-9)
- RS-485 Modbus

RESIDUAL CURRENT MONITORING

- Continuous residual current measurement
- Ideal for CGP
- Definition of a digital input for an exceedance

PROGRAMMABLE

- PLC functionality
- Graphic programming
- Jasic®

ALARM MANAGEMENT

- Individual forwarding via different channels, e.g. digital outputs
- Programmable
- Watchdog APPs

MEASUREMENT DATA MEMORY

- 256 MB / approx. 95.95 months (according to factory setting)
- Memory range up to 2 years
- User-defined memory segmentation

PERIPHERALS

- Digital inputs and outputs e.g. pulse or logic input
- Temperature measurement input

UMG 509-PRO

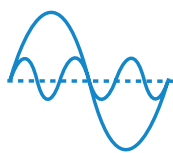
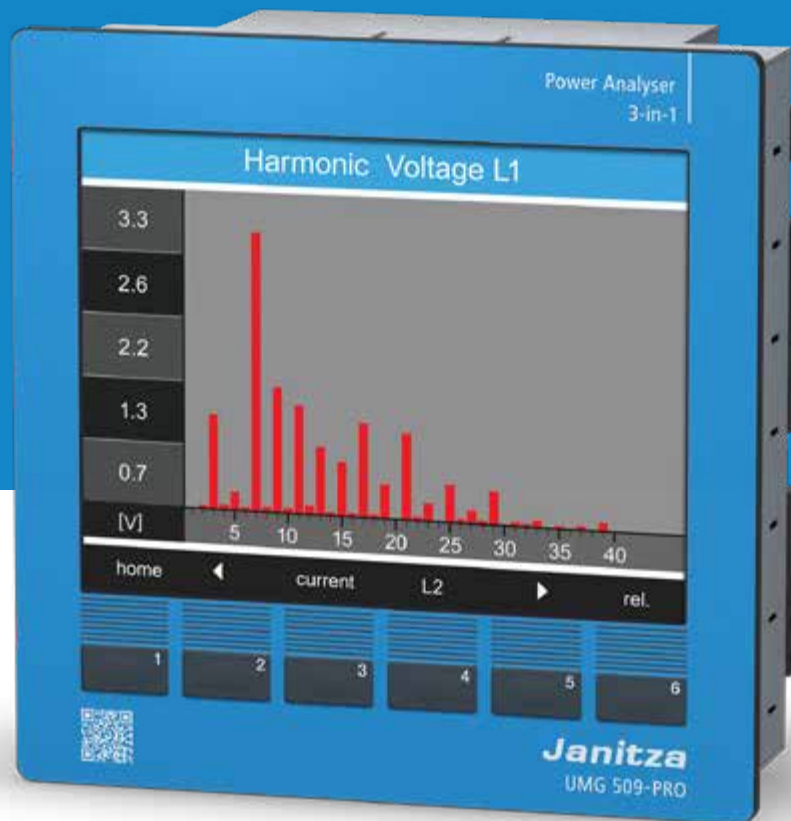

POWER QUALITY

Verification of the delivered power quality in the feeder

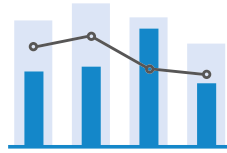

ENERGY MANAGEMENT

Additional features for energy data collection

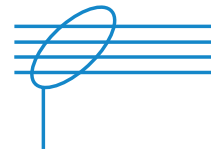

RCM

Detect central grounding point and other leakage currents

UMG 509-PRO – DIMENSIONED DRAWING

All dimensions in mm

Side view

Bottom view

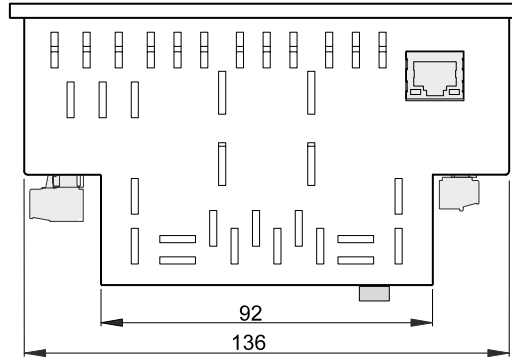
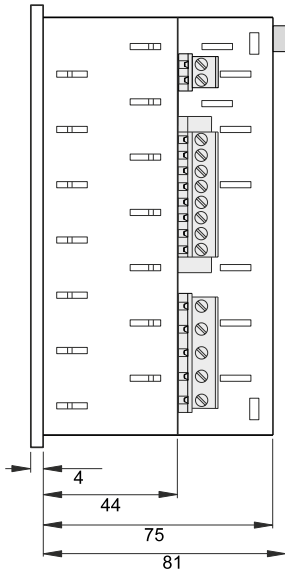

Cutout dimensions: 138^{+0.8} x 138^{+0.8} mm

UMG 509-PRO- CONNECTION EXAMPLE

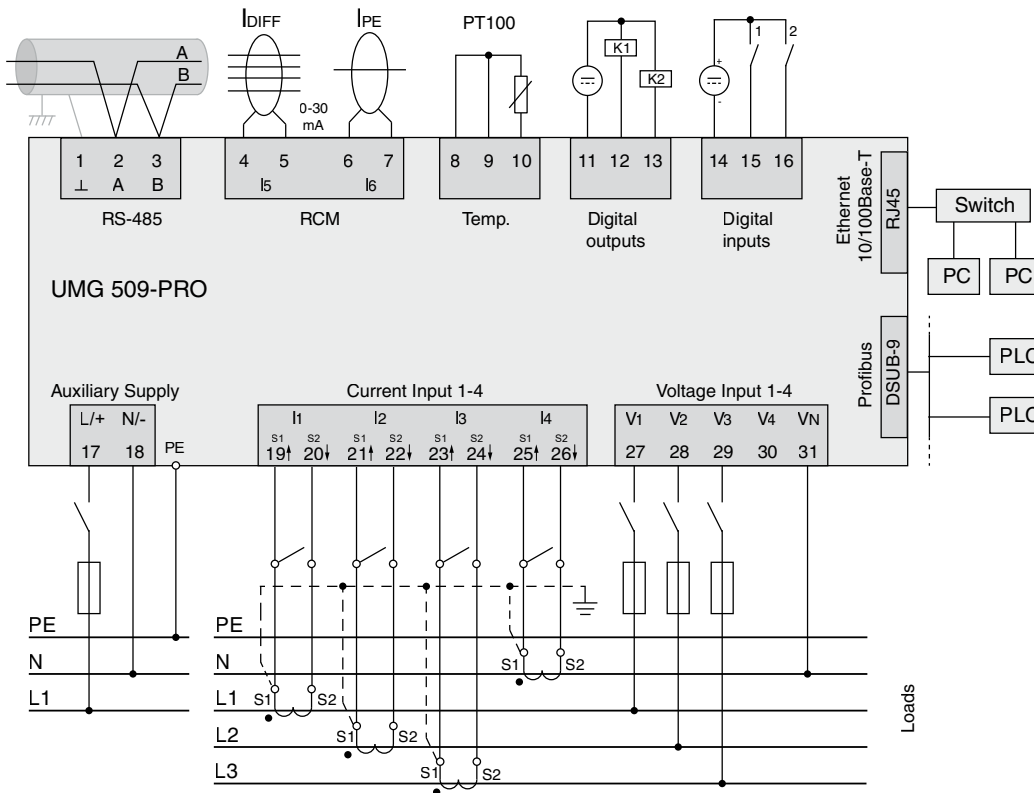

UMG 509-PRO – TECHNICAL DATA

UMG 509-PRO		
PART NUMBER	5226001	5226003
Supply voltage, AC	95 ... 240 VAC	48 ... 110 V AC
Supply voltage, DC	80 ... 300 VDC	24 ... 150 V DC
DEVICE OPTIONS		
BACnet communication	52.26.081	52.26.081
GENERAL		
Net weight (with attached plug-in connectors)	approx. 1080 g (2.38 lbs)	
Device dimensions (W x H x D)	approx. 144 x 75 x 144 mm (5.67 x 2.95 x 5.67 in)	
Battery	Type Li-Mn CR2450, 3V (UL 1642 approval)	
Clock (in the temperature range from -40 °C to 85 °C)	±5 ppm (equivalent to 3 minutes per year)	
TRANSPORT AND STORAGE		
The following information applies to devices that are transported or stored in their original packaging.		
Free fall	1 m	
Temperature	-25 °C to +70 °C (-13 °F to 158 °F)	
ENVIRONMENTAL CONDITIONS DURING OPERATION		
The device is intended for weather-protected, stationary use. The device must be connected to the ground wire terminal! Protection class I according to IEC 60536 (VDE 0106, Part 1).		
Working temperature range	-10 °C ... +55 °C (14 °F ... to 131 °F)	
Relative humidity	5 to 95% (at 25 °C/77 °F), no condensation	
Operating elevation	0 ... 2000 m above sea level	
Pollution degree	2	
Mounting orientation	vertical	
Ventilation	forced ventilation is not required.	
Protection against foreign matter and water		
Front	IP40 according to EN60529	
Rear	IP20 according to EN60529	
SUPPLY VOLTAGE		
Installation overvoltage category	300 V CAT III	
Protection of the supply voltage (fuse)	6 A, type B (approved according to UL/IEC)	
Option 230 V:		
– Nominal range	95 V ... 240 V (50/60 Hz) / DC 80 V ... 300 V	
– Operating range	± 10% of nominal range	
– Power consumption	max. 7 W / 14 VA	
Option 24 V:		
Nominal range	48 V ... 110 V (50/60 Hz) or DC 24 ... 150 V	
Operating range	± 10% of nominal range	
Power consumption	max. 9 W / 13 VA	
CONNECTION CAPACITY OF THE TERMINALS (SUPPLY VOLTAGE)		
Connectible conductors. Only one conductor may be connected per terminal!		
Single core, multi-core, fine-stranded	0.2 – 2.5 mm ² , AWG 24-12	
Terminal pins, wire ferrules	0.25 – 2.5 mm ²	
Tightening torque	0.5 – 0.6 Nm	
Strip length	7 mm (0.2756 in)	

CURRENT MEASUREMENT

Nominal current	5 A
Resolution	0.1 mA
Measuring range	0.005 ... 7 Arms
Overrange (overload)	from 7.5 Arms
Crest factor	2.4
Overvoltage category	Option 230 V: 300 V CAT III Option 24 V: 300 V CAT II
Rated surge voltage	4 kV
Power consumption	approx. 0.2 VA (Ri = 5 mΩ)
Overload for 1 s	120 A (sinusoidal)
Sampling frequency	20 kHz/phase

VOLTAGE MEASUREMENT

The voltage measurement inputs are suitable for measurement in the following power supply systems:	
Three-phase 4-conductor systems with rated voltages up to	417 V / 720 V 347 V / 600 V UL listed
Three-phase 3-conductor systems with rated voltages up to	600 V
The voltage measurement inputs are designed as follows in terms of safety and reliability:	
Overvoltage category	600 V CAT III
Rated surge voltage	6 kV
Protection of the voltage measurement	1 – 10 A
Measuring range L-N	0 ¹⁾ ... 600 Vrms
Measuring range L-L	0 ¹⁾ ... 1000 Vrms
Resolution	0.01 V
Crest factor	1.6 (relative to 600 Vrms)
Impedance	4 MΩ/phase
Power consumption	approx. 0.1 VA
Sampling frequency	20 kHz/phase
Transients	> 50 μs
Frequency of the fundamental oscillation	40 Hz ... 70 Hz
– Resolution	0.001 Hz

¹⁾ The device can only determine measured values if a voltage L-N of greater than 10 Vrms or a voltage L-L of greater than 18 Vrms is present at at least one voltage measurement input.

PHASE ANGLE MEASURING ACCURACY

0.075°

CONNECTION CAPACITY OF THE TERMINALS (VOLTAGE AND CURRENT MEASUREMENT)

Connectible conductors. Only one conductor may be connected per terminal!

Single core, multi-core, fine-stranded	0.2 – 2.5 mm ² , AWG 24-12
Terminal pins, wire ferrules	0.25 – 2.5 mm ²
Tightening torque	0.5 – 0.6 Nm
Strip length	7 mm

RESIDUAL CURRENT MEASUREMENT (RCM)

Nominal current	30 mArms
Measuring range	0 ... 40 mArms
Operating current	100 μA
Resolution	1 μA
Crest factor	1.414 (relative to 40 mA)
Load	4 Ω
Overload for 1 s	5 A
Constant overloaded	1 A
Overload 20 ms	50 A
Measurement of residual currents	according to IEC/TR 60755 (2008-01), type A
Maximum external load	300 Ω (for cable break detection)

CONNECTION CAPACITY OF THE TERMINALS (RESIDUAL CURRENT MEASUREMENT)

Connectible conductors. Only one conductor may be connected per terminal!

Rigid/flexible	0.14 – 1.5 mm ² , AWG 28-16
Flexible with wire ferrules without plastic sleeve	0.20 – 1.5 mm ²
Flexible with wire ferrules with plastic sleeve	0.20 – 1.5 mm ²
Strip length	7 mm (0.2756 in)
Tightening torque	0.20 – 0.25 Nm (1.77–2.21 lbf in)
Line length	up to 30 m not shielded; greater than 30 m shielded

TEMPERATURE MEASUREMENT INPUT

3-wire measurement

Update time	1 second
Connectible sensors	PT100, PT1000, KTY83, KTY84
Total load (sensor and cable)	max. 4 k Ω
Line length	up to 30 m not shielded; greater than 30 m shielded

SENSOR TYPE	TEMPERATURE RANGE	RESISTANCE RANGE	MEASUREMENT UNCERTAINTY
KTY83	-55° C to +175° C (-67 °F ..to 347 °F)	500 Ω ... 2.6 k Ω	± 1.5% rng
KTY84	-40° C to +300° C (-40 °F ..to 572 °F)	350 Ω ... 2.6 k Ω	± 1.5% rng
PT100	-99° C to +500° C (-146.2 °F ..to 932 °F)	60 Ω ... 180 Ω	± 1.5% rng
PT1000	-99° C to +500° C (-146.2 °F ..to 932 °F)	600 Ω ... 1.8 k Ω	± 1.5% rng

CONNECTION CAPACITY OF THE TERMINALS (TEMPERATURE MEASUREMENT INPUT)

Connectible conductors. Only one conductor may be connected per terminal!

Single core, multi-core, fine-stranded	0.08 – 1.5 mm ²
Terminal pins, wire ferrules	1 mm ²

DIGITAL INPUTS

2 digital inputs with a common ground

Maximum counter frequency	20 Hz
Response time (Jasic program)	200 ms
Input signal applied	18 V ... 28 V DC (typically 4 mA)
Input signal not applied	0 ... 5 V DC, current less than 0.5 mA
Line length	up to 30 m not shielded; greater than 30 m shielded

DIGITAL OUTPUTS

2 digital outputs with a common ground; optocoupler, not short-circuit proof

Operating voltage	20 V – 30 V DC (SELV or PELV supply)
Switching voltage	max. 60 VDC, 30 VAC
Switching current	max. 50 mAeff AC/DC
Response time (Jasic program)	200 ms
Output of voltage dips	20 ms
Output of voltage surges	20 ms
Switching frequency	max. 20 Hz
Line length	up to 30 m not shielded; greater than 30 m shielded

CONNECTION CAPACITY OF THE TERMINALS (DIGITAL INPUTS AND OUTPUTS)

Rigid/flexible	0.14 – 1.5 mm ² , AWG 28-16
Flexible with wire ferrules without plastic sleeve	0.25 – 1.5 mm ²
Flexible with wire ferrules with plastic sleeve	0.25 – 0.5 mm ²
Tightening torque	0.22 – 0.25 Nm (1.77 – 2.21 lbf in)
Strip length	7 mm (0.2756 in)

RS-485 INTERFACE

3-conductor connection with GND, A, B

Protocol	Modbus RTU/Slave, Modbus RTU/Master, Modbus RTU/Gateway
Transmission rate	9.6 kbps, 19.2 kbps, 38.4 kbps, 57.6 kbps, 115.2 kbps, 921.6 kbps
Termination resistor	Can be activated via microswitch

PROFIBUS INTERFACE

Connection	SUB D 9-pin
Protocol	Profibus DP/V0 according to EN 50170
Transmission rate	9.6 kBaud to 12 MBaud

ETHERNET INTERFACE

Connection	RJ45
Function	Modbus gateway, embedded web server (HTTP)
Protocols	CP/IP, EMAIL (SMTP), DHCP client (BootP), Modbus/TCP, Modbus RTU over Ethernet, FTP, ICMP (Ping), NTP, TFTP, BACnet (option), SNMP

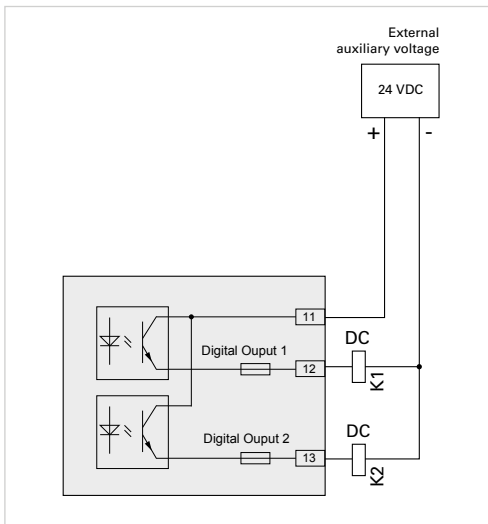

Fig.: Connection example of two electronic relays to the digital outputs

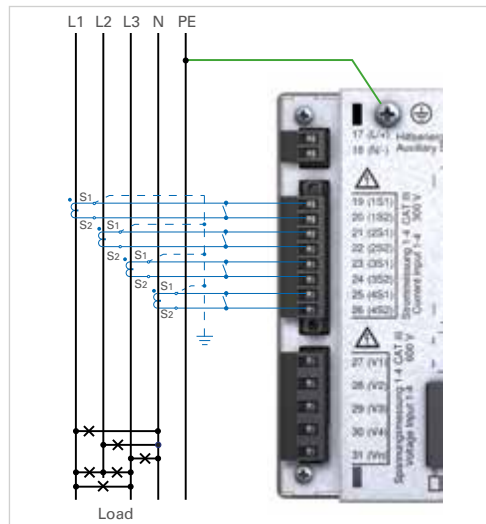

Fig.: Current measurement example

MAIN POWER SUPPLY, CGP AND IMPORTANT NODES

SECONDARY DISTRIBUTION

END CONSUMERS & FINAL CIRCUITS

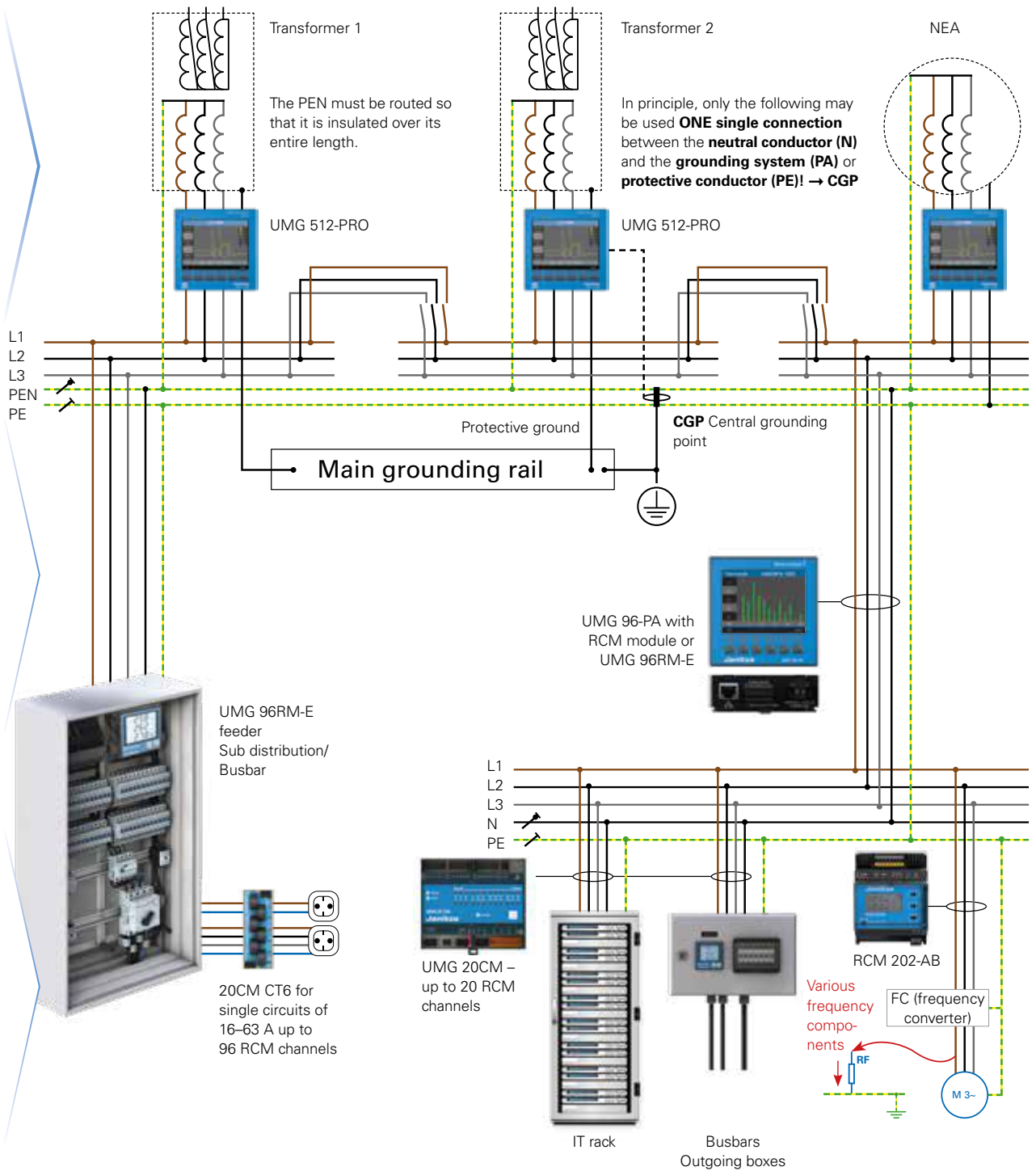

Fig.: Holistic energy & residual current monitoring

CERTIFIED POWER QUALITY ANALYZER

(CLASS A ACCORDING TO IEC 61000-4-30)



MEASURING ACCURACY

- Class A certified
- 512 measurement points per period
- Current & voltage: 0.1%

POWER QUALITY

- Harmonics current up to the 63rd harmonic
- Flicker measurement
- Events and transients
- Power quality analysis onboard
- EN 50160 and EN 61000-2-4

MEASUREMENT DATA MEMORY

- 256 MB / approx. 3.11 months (according to factory setting)
- Memory range up to 2 years
- User-defined memory segmentation

RESIDUAL CURRENT MONITORING

- Continuous residual current measurement
- Ideal for CGP

OPERATION

- Color graphic display & intuitive user guidance
- Graphic display of measured values

INTERFACES

- Ethernet
- Profibus (DSUB-9)
- RS-485 Modbus

PROGRAMMABLE

- PLC functionality
- Graphic programming
- Jasic®

DEVICE HOMEPAGE

- Device has own homepage
- Functional enhancement through APPs
- Remote control of the device display via the homepage
- Online data and historical data

UMG 512-PRO

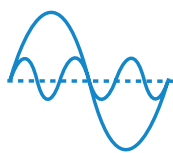
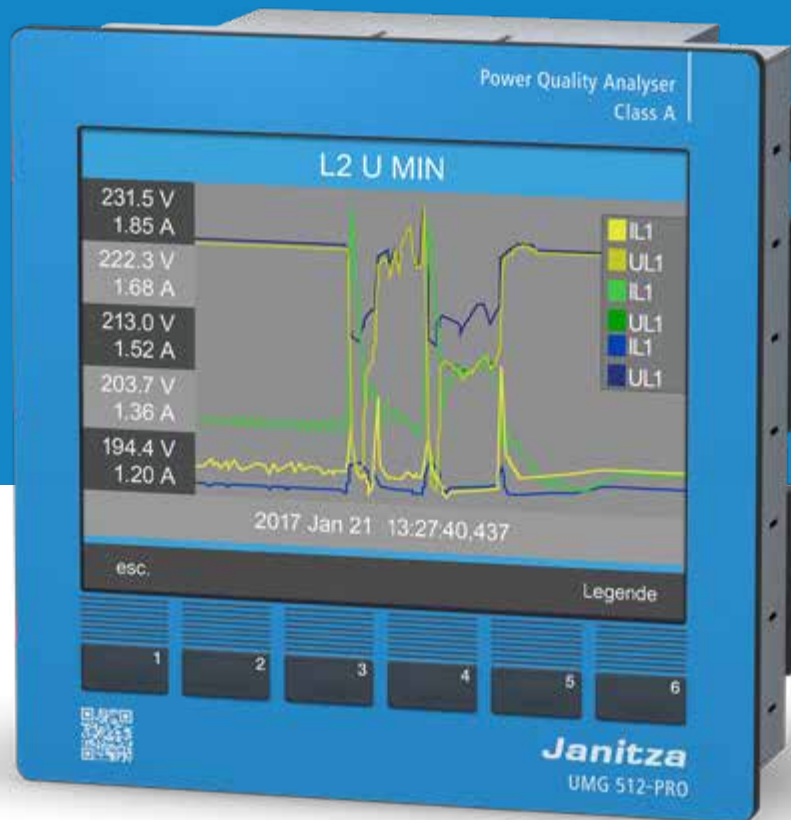

POWER QUALITY

Power quality analyzer according to IEC 61000-4-30 Class A



CERTIFICATION

Testing and certification by external testing laboratory



COMMUNICATION

Export of power quality data via COMTRADE format

UMG 512-PRO – DIMENSIONED DRAWING

All dimensions in mm

Side view

Bottom view

Rear view

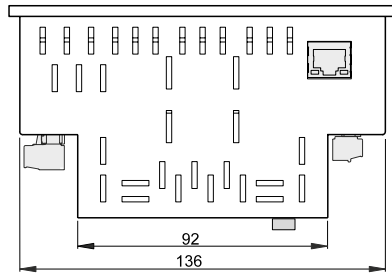
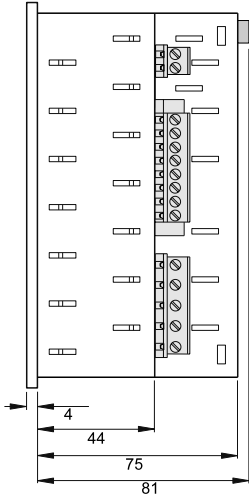

Cutout dimensions: 138^{+0.8} x 138^{+0.8} mm

UMG 512-PRO– CONNECTION EXAMPLE

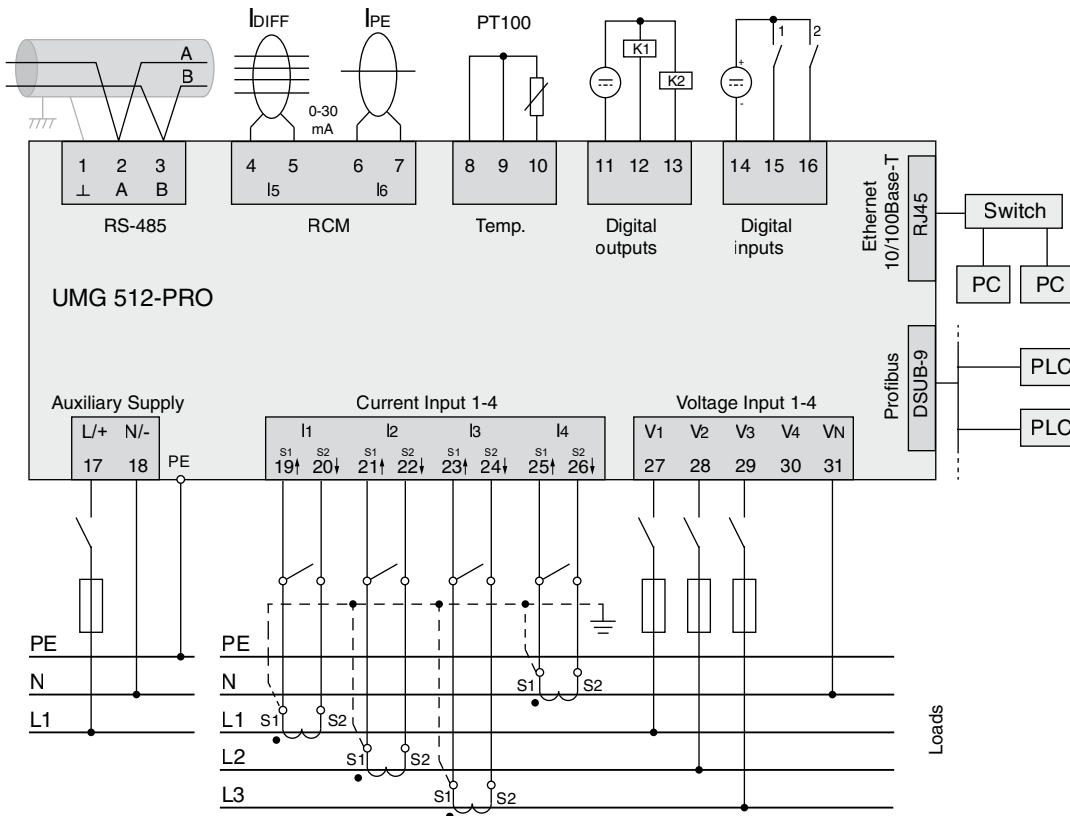

UMG 512-PRO – TECHNICAL DATA

UMG 512-PRO		
PART NUMBER	5217011	5217003
Supply voltage, AC	95 ... 240 VAC	48 ... 110 V AC
Supply voltage, DC	80 ... 300 VDC	24 ... 150 V DC
DEVICE OPTIONS		
BACnet communication	5217081	5217081
GENERAL		
Net weight (with attached plug-in connectors)	approx. 1080 g (2.38 lbs)	
Device dimensions (W x H x D)	approx. 144 x 144 x 75 mm (5.64 x 5.64 x 2.95 in)	
Battery	Type Li-Mn CR2450, 3 V (approval according to UL 1642)	
Clock (temperature range from -40 °C to +85 °C)	±5 ppm (equivalent to 3 minutes per year)	
TRANSPORT AND STORAGE		
The following information applies to devices that are transported or stored in their original packaging.		
Free fall	1 m (39.37 in)	
Temperature	-25 °C to +70 °C (-13 °F to 158 °F)	
ENVIRONMENTAL CONDITIONS DURING OPERATION		
The device is intended for weather-protected, stationary use and must be connected to the ground wire terminal! Protection class I according to IEC 60536 (VDE 0106, Part 1).		
Working temperature range	-10 °C ... +55 °C (14 °F to 131 °F)	
Relative humidity	5 to 95% (at 25 °C/77 °F), no condensation	
Operating elevation	0 ... 2000 m (6562 ft) above sea level	
Pollution degree	2	
Mounting orientation	vertical	
Ventilation	forced ventilation is not required.	
Protection against foreign matter and water		
– Front	IP40 according to EN60529	
– Rear	IP20 according to EN60529	
SUPPLY VOLTAGE		
Installation overvoltage category	300 V CAT III	
Protection of the supply voltage (fuse)	6 A, Type B (approved according to UL/IEC)	
Option 230 V:		
– Nominal range	95 V ... 240 V (50/60 Hz) / DC 80 V .. 300 V	
– Operating range	± 10% of nominal range	
– Power consumption	max. 7 W / 14 VA	
Option 24 V:		
– Nominal range	48 V ... 110 V (50/60 Hz) / DC 24 ... 150 V	
– Operating range	± 10% of nominal range	
– Power consumption	max. 9 W / 13 VA	
CONNECTION CAPACITY OF THE TERMINALS (SUPPLY VOLTAGE)		
Connectible conductors. Only one conductor may be connected per terminal!		
Single core, multi-core, fine-stranded	0.2 – 4 mm ² , AWG 28-12	
Wire ferrules (non-insulated)	0.2 – 2.5 mm ² , AWG 26-14	
Wire ferrules (insulated)	0.2 – 2.5 mm ² , AWG 26-14	
Tightening torque	0.4 – 0.5 Nm (3.54 – 4.43 lbf in)	
Strip length	7 mm (0.2756 in)	

CURRENT MEASUREMENT

Nominal current	5 A
Resolution	0.1 mA
Measuring range	0.005 .. 7 Arms
Overrange (overload)	from 8.5 Arms
Crest factor	1.41
Overvoltage category	Option 230 V: 300 V CAT III Option 24 V: 300 V CAT II
Rated surge voltage	4 kV
Power consumption	approx. 0.2 VA (Ri = 5 mΩ)
Overload for 1 s	120 A (sinusoidal)
Sampling frequency	25.6 kHz / phase

VOLTAGE MEASUREMENT

The voltage measurement inputs are suitable for measurement in the following power supply systems:

Three-phase 4-conductor systems with rated voltages up to	417 V / 720 V (+10%) 347 V / 600 V (UL listed)
Three-phase 3-conductor systems with rated voltages up to	600 V (+10%)
The voltage measurement inputs are designed as follows in terms of safety and reliability:	
Overvoltage category	600 V CAT III
Rated surge voltage	6 kV
Protection of the voltage measurement	1–10 A
Measuring range L-N	0 ¹⁾ ... 600 Vrms
Measuring range L-L	0 ¹⁾ ... 1000 Vrms
Resolution	0.01 V
Crest factor	1.6 (relative to 600 Vrms)
Impedance	4 MΩ/phase
Power consumption	approx. 0.1 VA
Sampling frequency	25.6 kHz / phase
Transients	39 μs
U _{din2}) according to EN61000-4-30	100 ... 250 V
Flicker range (dU/U)	27.5 %
Frequency of the fundamental oscillation – Resolution	15 Hz ... 440 Hz 0.001 Hz

¹⁾ The device can only determine measured values if a voltage L-N of greater than 10 Vrms or a voltage L-L of greater than 18 Vrms is present at at least one voltage measurement input.

²⁾ U_{din} = Agreed input voltage according to DIN EN 61000-4-30

PHASE ANGLE MEASURING ACCURACY

0.075°

CONNECTION CAPACITY OF THE TERMINALS (VOLTAGE MEASUREMENT)

Connectible conductors. Only one conductor may be connected per terminal!

Single core, multi-core, fine-stranded	0.2 – 4 mm ² , AWG 28-12
Wire ferrules (non-insulated)	0.2 – 2.5 mm ² , AWG 26-14
Wire ferrules (insulated)	0.2 – 2.5 mm ² , AWG 26-14
Tightening torque	0.4 – 0.5 Nm (3.54 – 4.43 lbf in)
Strip length	7 mm (0.2756 in)

CONNECTION CAPACITY OF THE TERMINALS (CURRENT MEASUREMENT)

Connectible conductors. Only one conductor may be connected per terminal!

Single core, multi-core, fine-stranded	0.2 – 4 mm ² , AWG 28-12
Wire ferrules (non-insulated)	0.2 – 4 mm ² , AWG 26-12
Wire ferrules (insulated)	0.2 – 2.5 mm ² , AWG 26-14
Tightening torque	0.4 – 0.5 Nm (3.54 – 4.43 lbf in)
Strip length	7 mm (0.2756 in)

RESIDUAL CURRENT MEASUREMENT (RCM)

Nominal current	30 mArms
Measuring range	0 ... 40 mArms
Operating current	100 μ A
Resolution	1 μ A
Crest factor	1.414 (relative to 40 mA)
Load	4 Ω
Overload for 1 s	5 A
Constant overloaded	1 A
Overload 20 ms	50 A
Measurement of residual currents	according to IEC/TR 60755 (2008-01), type A
Maximum external load	300 Ω (for cable break detection)

CONNECTION CAPACITY OF THE TERMINALS (RESIDUAL CURRENT MEASUREMENT)

Connectible conductors. Only one conductor may be connected per terminal!

Single core, multi-core, fine-stranded	0.2 – 1.5 mm ² , AWG 28-16
Wire ferrules (non-insulated)	0.2 – 1.5 mm ² , AWG 26-16
Wire ferrules (insulated)	0.2 – 1.5 mm ² , AWG 26-16
Tightening torque	0.2 – 0.25 Nm (1.77 – 2.21 lbf in)
Stripping length 7 mm	7 mm (0.2756 in)
Line length	Up to 30 m (32.81 yd) not shielded; Greater than 30 m (32.81 yd) shielded

POTENTIAL ISOLATION AND ELECTRICAL SAFETY OF THE RESIDUAL CURRENT MEASUREMENT INPUTS

- The RCM measurement inputs are double-insulated from the current and voltage measurement inputs and the supply voltage.
- There is no isolation to the temperature measurement input.
- There is only functional isolation to the Ethernet, Profibus, RS-485 and digital I/O interfaces.
- The connected residual current transformers and the lines to be measured must each have at least one additional or basic insulation in accordance with IEC61010-1:2010 for the mains voltage that is applied.

TEMPERATURE MEASUREMENT INPUT

3-wire measurement

Update time	1 second
Connectible sensors	PT100, PT1000, KTY83, KTY84
Total load (sensor and cable)	max. 4 k Ω
Line length	Up to 30 m (32.81 yd) not shielded; Greater than 30 m (32.81 yd) shielded

SENSOR TYPE	TEMPERATURE RANGE	RESISTANCE RANGE	MEASUREMENT UNCERTAINTY
KTY83	–55° C ... +175° C (–67 °F ..to 347 °F)	500 Ω ... 2.6 k Ω	±1.5% rng
KTY84	–40° C ... +300° C (–40 °F ..to 572 °F)	350 Ω ... 2.6 k Ω	±1.5% rng
PT100	–99° C ... +500° C (–146.2 °F ..to 932 °F)	60 Ω ... 180 Ω	±1.5% rng
PT1000	–99° C ... +500° C (–146.2 °F ..to 932 °F)	600 Ω ... 1.8 k Ω	±1.5% rng

CONNECTION CAPACITY OF THE TERMINALS (TEMPERATURE MEASUREMENT INPUT)

Connectible conductors. Only one conductor may be connected per terminal!

Single core, multi-core, fine-stranded	0.2 – 1.5 mm ² , AWG 28-16
Wire ferrules (non-insulated)	0.2 – 1.5 mm ² , AWG 26-16
Wire ferrules (insulated)	0.2 – 1.5 mm ² , AWG 26-16
Tightening torque	0.2 – 0.25 Nm (1.77 – 2.21 lbf in)
Strip length	7 mm (0.2756 in)

POTENTIAL ISOLATION AND ELECTRICAL SAFETY OF THE TEMPERATURE MEASUREMENT INPUTS

- The temperature measurement input is double-insulated from the current and voltage measurement inputs and the supply voltage.
- There is no isolation from the RCM measuring input.
- There is only functional isolation to the Ethernet, Profibus, RS-485 and digital I/O interfaces.
- The external temperature sensor must be double insulated relative to system components with dangerous contact voltage (according to IEC61010-1:2010).

DIGITAL INPUTS

2 digital inputs with a common ground

Maximum counter frequency	20 Hz
Response time (Jasic program)	200 ms
Input signal applied	18 V ... 28 V DC (typically 4 mA) (SELV or PELV supply)
Input signal not applied	0 ... 5 V DC, current less than 0.5 mA
Line length	Up to 30 m (32.81 yd) not shielded; Greater than 30 m (32.81 yd) shielded

DIGITAL OUTPUTS

2 digital outputs with a common ground; optocoupler, not short-circuit proof

Operating voltage	20 V – 30 V DC (SELV or PELV supply)
Switching voltage	Max. 60 V DC
Switching current	max. 50 mAeff AC/DC
Response time (Jasic program)	200 ms
Switching frequency	max. 20 Hz
Line length	Up to 30 m (32.81 yd) not shielded; Greater than 30 m (32.81 yd) shielded

CONNECTION CAPACITY OF THE TERMINALS (DIGITAL INPUTS AND OUTPUTS)

Connectible conductors. Only one conductor may be connected per terminal!

Single core, multi-core, fine-stranded	0.2 – 1.5 mm ² , AWG 28-16
Wire ferrules (non-insulated)	0.2 – 1.5 mm ² , AWG 26-16
Wire ferrules (insulated)	0.2 – 1.5 mm ² , AWG 26-16
Tightening torque	0.2 – 0.25 Nm (1.77 – 2.21 lbf in)
Strip length	7 mm (0.2756 in)

POTENTIAL ISOLATION AND ELECTRICAL SAFETY OF THE DIGITAL INPUTS AND OUTPUTS

- The digital inputs and outputs are double-insulated from the current and voltage measurement inputs and the supply voltage.
- Relative to each other and to the Ethernet, Profibus, RS-485 and digital I/O interfaces there is only functional isolation.
- The auxiliary voltage to be connected externally must be implemented with SELV or PELV.

RS-485 INTERFACE

3-conductor connection with GND, A, B

Protocol	Modbus RTU/Slave, Modbus RTU/Master, Modbus RTU/Gateway
Transmission rate	9.6 kbps, 19.2 kbps, 38.4 kbps, 57.6 kbps, 115.2 kbps, 921.6 kbps
Termination resistor	Can be activated via microswitch

TERMINAL CONNECTION CAPACITY (SERIAL INTERFACE – RS-485)

Connectible conductors. Only one conductor may be connected per terminal!

Single core, multi-core, fine-stranded	0.2 – 1.5 mm ² , AWG 28-16
Wire ferrules (non-insulated)	0.2 – 1.5 mm ² , AWG 26-16
Wire ferrules (insulated)	0.2 – 1.5 mm ² , AWG 26-16
Tightening torque	0.2 – 0.25 Nm (1.77 – 2.21 lbf in)
Strip length	7 mm (0.2756 in)

PROFIBUS INTERFACE

Connection	SUB D 9-pin
Protocol	Profibus DP/V0 according to EN 50170
Transmission rate	9.6 kBaud to 12 MBaud

ETHERNET INTERFACE

Connection	RJ45
Function	Modbus gateway, embedded web server (HTTP)
Protocols	CP/IP, EMAIL (SMTP), DHCP client (BootP), Modbus/TCP, Modbus RTU over Ethernet, FTP, ICMP (Ping), NTP, TFTP, BACnet (option), SNMP

POTENTIAL ISOLATION AND ELECTRICAL SAFETY OF THE INTERFACES

- The RS-485, Profibus and Ethernet interfaces are double insulated from the current and voltage measurement inputs as well as from the supply voltage.
- Relative to each other and to the RCM and temperature as well as the digital I/O measuring inputs there is only functional isolation.
- The interfaces of the devices connected here must have double or reinforced insulation from mains voltages (according to IEC 61010-1: 2010).

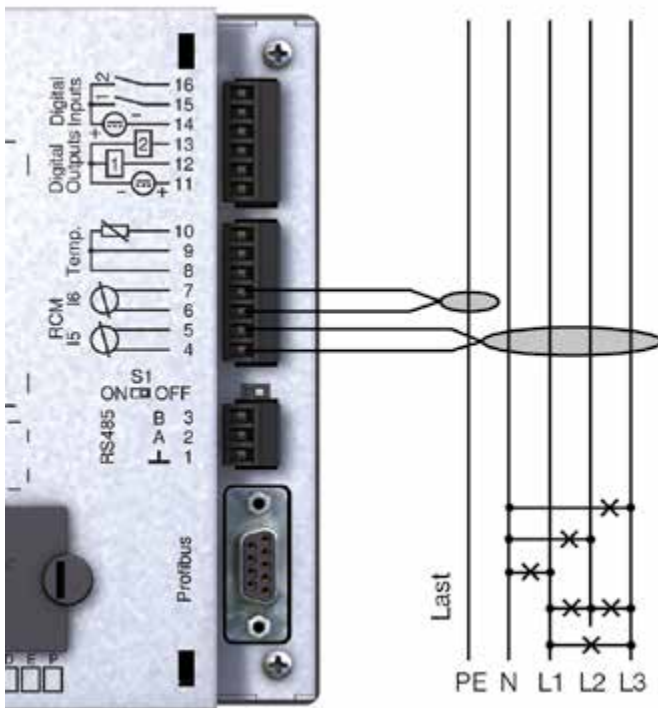

Fig.: Connection example for residual current measurement and PE via current transformer

DIN RAIL MEASUREMENT DEVICES



UMG 806
Modularly expandable
universal measurement device



UMG 103-CBM
Compact energy analyzer



UMG 801
Modularly expandable
network analyzer



UMG 604-PRO
Functionally expandable
network analyzer



UMG 605-PRO
Power quality analyzer Class S
according to IEC 61000-4-30



UMG 20CM
Multi-channel operating
current and residual current
monitoring device



RCM 202-AB
Residual current monitoring
device Type AB



RCM 201-ROGO
Residual current monitoring
device Type A with Rogowski
current transformer



MID energy meters
MID and IEC calibrated ex works,
lead-sealed terminal cover

DIN RAIL MEASUREMENT DEVICES



Overviews	98	UMG 806	Modularly expandable universal measurement device
	108	UMG 103-CBM	Compact energy analyzer
	114	UMG 801	Modularly expandable power analyzer
	132	UMG 604-PRO	Functionally expandable power analyzer
	140	UMG 605-PRO	Power quality analyzer (Class S according to IEC 61000-4-30)
	146	UMG 20CM	Multi-channel operating current and residual current meter
	156	RCM 202-AB	Residual current monitor, type AB
	162	RCM 201-ROGO	Residual current monitor, type A
	166	MID energy meters	MID and IEC calibrated ex works

MODULARLY EXPANDABLE UNIVERSAL MEASUREMENT DEVICE



COMMUNICATION

- RS-485
- Modbus TCP – via module
- SNMP V2c – via module

POWER QUALITY

- Harmonics current up to the 31st harmonic
- Unbalance
- Distortion factor THD-U / THD-I

PERIPHERALS

- Pulse output
- Thermistor input

MEASURING ACCURACY

- Class 0.2S
- Voltage 0.2%
- Sampling frequency 8 kHz

OPERATION

- Operation directly via device display
- 2-button operation

RESIDUAL CURRENT DETECTION

- RCM input onboard
- Detect residual currents at an early stage

MODULARITY

- Enhancement module for Ethernet communication
- Analog input module for additional analog inputs and relay outputs
- Digital input module for additional digital inputs and relay outputs

MEASUREMENT DATA MEMORY

- Internal 4 MB data memory
- Data security through redundant measurement data storage

UMG 806

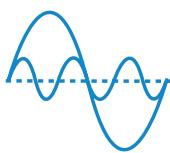

POWER QUALITY

Important basic parameters for assessing power quality

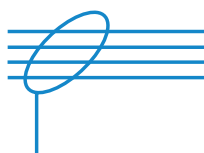

RCM

Residual current detection for personal and fire protection purposes

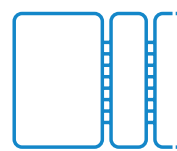

MODULAR

Retrofit Ethernet interface and additional inputs and outputs

UMG 806 – DIMENSIONED DRAWING

All dimensions in mm

Front view

Side view

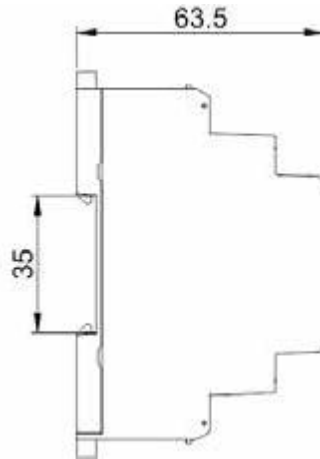
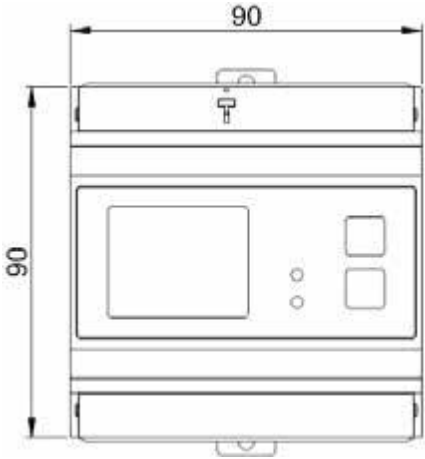

UMG 806 – CONNECTION EXAMPLE

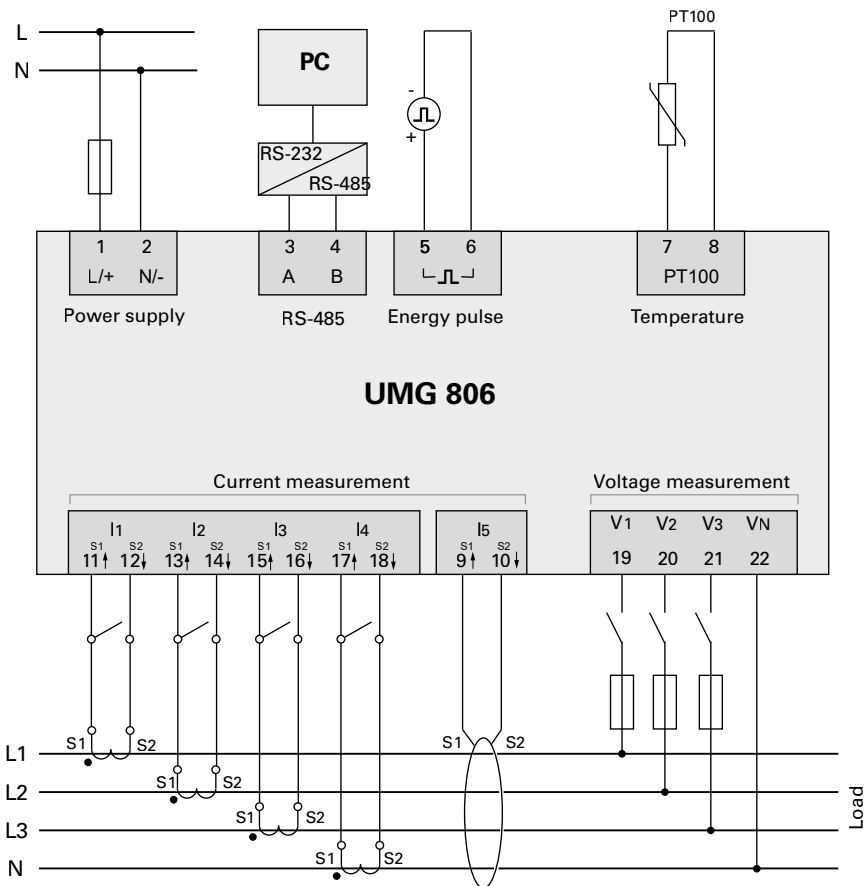

UMG 806 – TECHNICAL DATA

UMG 806	
PART NUMBER	1402025
GENERAL	
Supply voltage	80 ... 270 VAC; 80 ... 270 VDC
Net weight	300 g (0.66 lb)
Device dimensions	Approx. B = 90 mm (3.54 in), H = 90 mm (3.54 in), D = 63.5 mm (2.5 in)
Battery	Type Li-Mn CR2032, 3 V
Backlight service life	45000 h (50% of the initial brightness)
Mounting orientation	As desired
Impact resistance	IK04 according to IEC 62262
TRANSPORT AND STORAGE (The following specifications apply for devices transported and stored in the original packaging)	
Free fall	1 m (39.37 in)
Temperature	-30° C (-17.2 °F) to +80° C (176 °F)
Relative humidity	5 to 95 % RH at 77 °F (25 °C), non-condensing
ENVIRONMENTAL CONDITIONS DURING OPERATION	
The device is for weather-protected and stationary use. ... fulfills operating conditions according to DIN IEC 60721-3-3. ... has protection class II according to IEC 60536 (VDE 0106, part 1), a ground wire connection is not required!	
Rated temperature range	-25 °C (-13 °F) to +70 °C (158 °F)
Relative humidity	5 to 95% at 77 °F (25 °C), non-condensing
Operating elevation/overvoltage category	< 2500 m (13123 ft) above sea level
Pollution degree	2
Ventilation	No forced ventilation required
Protection against foreign matter and water	IP20 according to EN60529
SUPPLY VOLTAGE	
Nominal range	AC/DC: 80 V – 270 V
Operating range	± 10% of nominal range
Power consumption	max. 7 VA
Recommended overcurrent protective device for line protection	5 A, (Char. B), IEC-/UL approval
VOLTAGE MEASUREMENT	
3-phase 4-conductor systems with rated voltages up to	230 V _{LN} / 400 V _{LL} (± 10%) acc. to IEC
3-phase 3-conductor systems (grounded) with rated voltages up to	400 V _{LL} (± 10%) acc. to IEC
Overvoltage category	300 V CAT III according to IEC
Rated surge voltage	4 kV
Protection of the voltage measurement	1 - 10 A tripping characteristic B (with IEC/UL approval)
Measuring range L-N	0 .. 230 V _{rms} (max. overvoltage 277 V _{rms})
Measuring range L-L	0 .. 400 V _{rms} (max. overvoltage 480 V _{rms})
Resolution	0.1 V
Crest factor	2 (referred to measuring range 230 V L-N)
Impedance	>1.7 MΩ/phase
Power consumption	approx. 0.1 VA / phase
Sampling frequency	8 kHz / phase
Frequency of fundamental oscillation	45 Hz .. 65 Hz
- Resolution	0.01 Hz
Harmonics	1 .. 31st

CURRENT MEASUREMENT (.../1 A) (.../5 A)

Nominal current	5 A
Channels	4
Measuring range	0.005 .. 6 A _{eff}
Crest factor (relative to the nominal current)	2
Overload for 1 s	100 A (sinusoidal)
Resolution	1 mA
Overvoltage category	300 V CATII
Rated surge voltage	4 kV
Power consumption	approx. 0.2 VA
Sampling frequency	8 kHz
Harmonics	1 .. 31st

CURRENT MEASUREMENT (MEASURING RANGE 0 .. 40 MA, AC)

Channel I5	1
------------	---

DIGITAL OUTPUT (energy pulse output)

Switching voltage	max. 35 V DC
Switching current	max. 10 mA _{eff} DC
Response time	approx. 500 ms
Pulse width	80 ms ± 20%
Digital output (energy pulses)	max. 10 Hz

TEMPERATURE MEASUREMENT

Update time	1 s
Total load (sensor and cable)	max. 0.35 kΩ
Suitable sensor types	PT100

CABLE LENGTH (DIGITAL OUTPUT, TEMPERATURE MEASUREMENT)

Up to 30 m (32.81 yd)	Unshielded
Greater than 30 m (32.81 yd)	Shielded

RS-485 INTERFACE (2-wire connection)

Protocol	Modbus RTU
Transmission rate	up to 115.2 kbps

CONNECTION CAPACITY OF THE TERMINALS (supply voltage)

Connectible conductors. Only connect one conductor per terminal!

Single core, multi-core, fine-stranded	0.14 – 2.5 mm ² , AWG 26-14
Wire ferrules (non-insulated)	0.25 – 2.5 mm ² , AWG 23-14
Wire ferrules (insulated)	0.25 – 1.5 mm ² , AWG 23-16
Tightening torque	0.5 – 0.6 Nm (4.43 – 5.31 lbf in)
Strip length	7 mm (0.2756 in)

CONNECTION CAPACITY OF THE TERMINALS (current measurement)

Connectible conductors. Only connect one conductor per terminal!

Single core, multi-core, fine-stranded	0.2 – 4 mm ² , AWG 24-12
Wire ferrules (non-insulated)	0.25 – 2.5 mm ² , AWG 23-14
Wire ferrules (insulated)	0.25 – 1.5 mm ² , AWG 23-16
Tightening torque	0.5 – 0.6 Nm (4.43 – 5.31 lbf in)
Strip length	7 mm (0.2756 in)

CONNECTION CAPACITY OF THE TERMINALS (voltage measurement)

Connectible conductors. Only connect one conductor per terminal!

Single core, multi-core, fine-stranded	0.2 – 4 mm ² , AWG 24-12
Wire ferrules (insulated/non-insulated)	0.25 – 2.5 mm ² , AWG 23-14
Strip length	7 mm (0.2756 in)

CONNECTION CAPACITY OF THE TERMINALS (RS-485, digital output, temperature measurement)

Single core, multi-core, fine-stranded	0.2 – 4 mm ² , AWG 24-12
Wire ferrules (non-insulated)	0.25 – 2.5 mm ² , AWG 23-14
Wire ferrules (insulated)	0.25 – 1.5 mm ² , AWG 23-16
Tightening torque	0.5 – 0.6 Nm (4.43 – 5.31 lbf in)
Strip length	7 mm (0.2756 in)

*Busbar feeders in a computer center*

MODULAR EXPANSIONS FOR THE UMG 806 METER

806-EC1 module

- Ethernet communication module
- Modbus TCP
- SNMP V2Cc

Module 806-E11

- Analog input module
- Monitoring and evaluation of external signals and sensors
- Inputs: four at 4 ... 20 mA
- Outputs: two relay outputs



806-ED1 module

- Digital input module
- Integration of digital inputs and relay outputs
- Inputs: four digital inputs
- Outputs: two relay outputs

MODULE 806-EC1 – DIMENSIONED DRAWING

All dimensions in mm

Front view

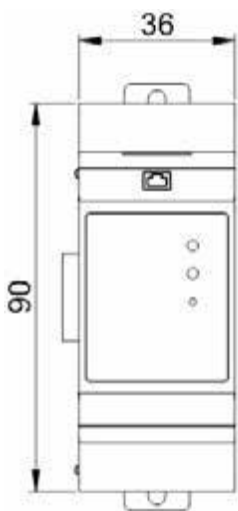

Side view

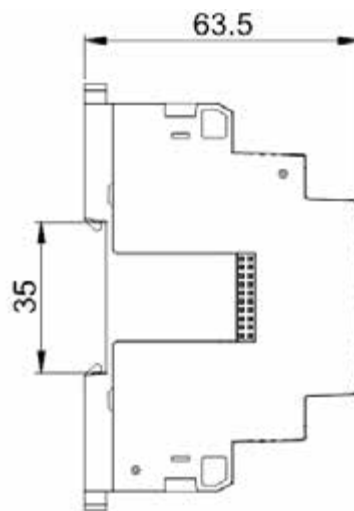

MODULE 806-ED1 – DIMENSIONED DRAWING

All dimensions in mm

Front view

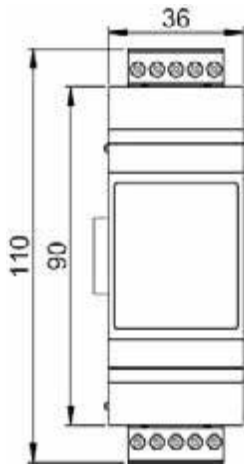

Side view

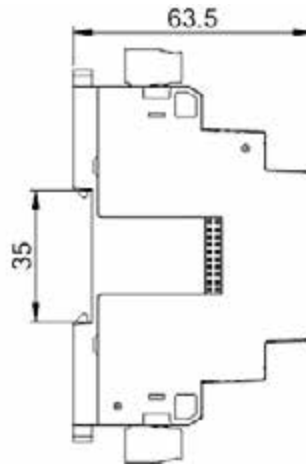

MODULE 806-EL1 – DIMENSIONED DRAWING

All dimensions in mm

Front view

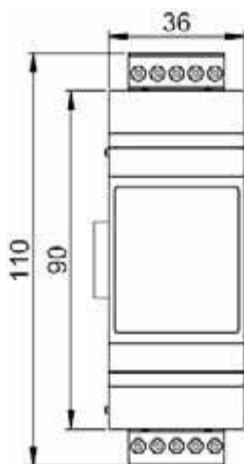

Side view

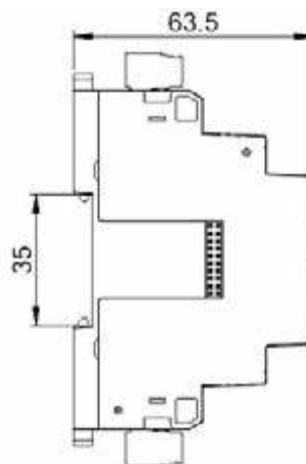

UMG 806 MODULES – TECHNICAL DATA

UMG 806 MODULES			
MODULE	806-EC1	806-EI1	806-ED1
PART NUMBER	1402016	1402020	1402019
Net weight	82 g (0.18 lbs)	91 g (0.20 lb)	82 g (0.18 lbs)
GENERAL			
Device dimensions	B = 36 mm (1.42 in), H = 90 mm (3.54 in), T = 63.5 mm (2.5 in)		
Mounting orientation	As desired		
Installation - suitable DIN rails - 35 mm (1.38")	According to EN 60715		
Impact resistance	IK04 according to IEC 62262		
TRANSPORT AND STORAGE (The following specifications apply for devices transported and stored in the original packaging)			
Free fall	1 m (39.37 in)		
Temperature	-40 °C (-40 °F) to +85 °C (185 °F)		
Relative humidity	5 to 95% RH at 25 °C (77 °F), non-condensing		
ENVIRONMENTAL CONDITIONS DURING OPERATION			
The device is for weather-protected and stationary use. ... fulfills operating conditions according to DIN IEC 60721-3-3. ... has protection class II according to IEC 60536 (VDE 0106, part 1), a ground wire connection is not required!			
Rated temperature range	-40 °C (-40 °F) to +70 °C (158 °F)		
Relative humidity	5 to 95% at 77 °F (25 °C), non-condensing		
Operating elevation	< 2500 m (13123 ft) above sea level		
Pollution degree	2		
Ventilation	No forced ventilation required		
Protection against foreign matter and water	IP20 according to EN60529		
MODULE 806-EC1 Ethernet communication module			
Interface	RJ45 (10M)		
Transmission technology	IEE 802.3		
Operating mode	Server		
MAC	IEEE certification		
IP	Static		
Protocol	Modbus/TCP, SNMP V2c		
Function	Modbus gateway		
Isolation voltage	1.5 kV AC		



The basic device is compatible with every type 806 module

COMPACT ENERGY ANALYZER



COMPARATOR

- Limit value monitoring of current, voltage, power

INTERFACES

- RS-485

MEASURED VOLTAGE

- No additional supply necessary

DESIGN

- Low installation depth
- Compatible with sub distributors
- DIN rail: No door cutout necessary
- Up to 8 meters on a DIN rail in a 600 mm cabinet

MEASUREMENT DATA MEMORY

- 4 MB / approx. 3 months (according to factory setting)

MEASURING ACCURACY

- Class 0.2S
- Current: 0.5%
- Voltage: 0.2%
- Sampling frequency 5.4 kHz

POWER QUALITY

- Harmonics current up to the 40th harmonic
- Distortion factor THD-U / THD-I
- Minimum & maximum values

UMG 103-CBM

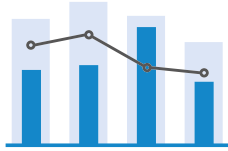

ENERGY MANAGEMENT

Storage of historical values
and subsequent analysis

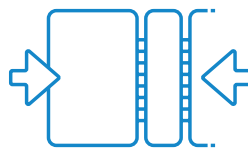

COMPACT

Low installation depth ->
Compatible with sub distributors

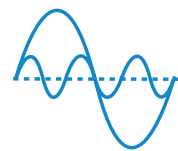

POWER QUALITY

Measurement up to the
40th harmonic

UMG 103-CBM – DIMENSIONED DRAWING

All dimensions in mm

Front view

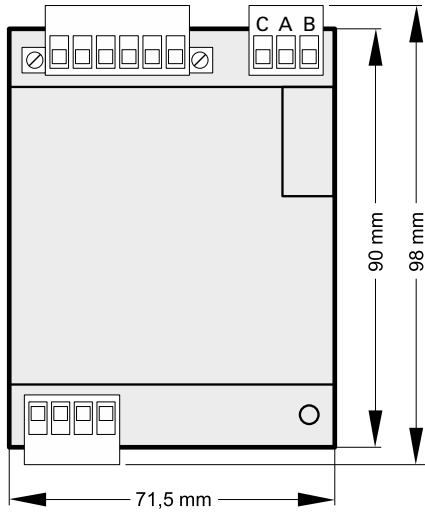

Side view

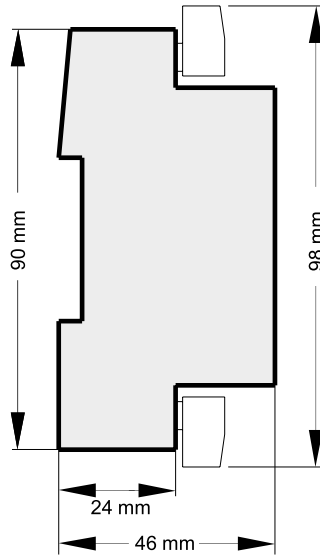

UMG 103-CBM – CONNECTION EXAMPLE

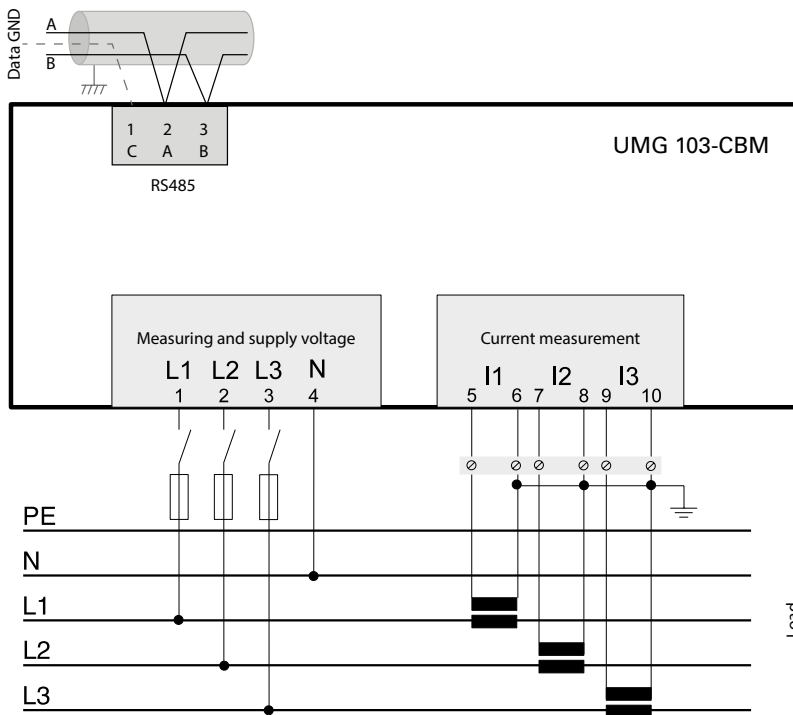

UMG 103-CBM – ILLUSTRATION OF TYPICAL APPLICATION WITH 2 FEEDERS

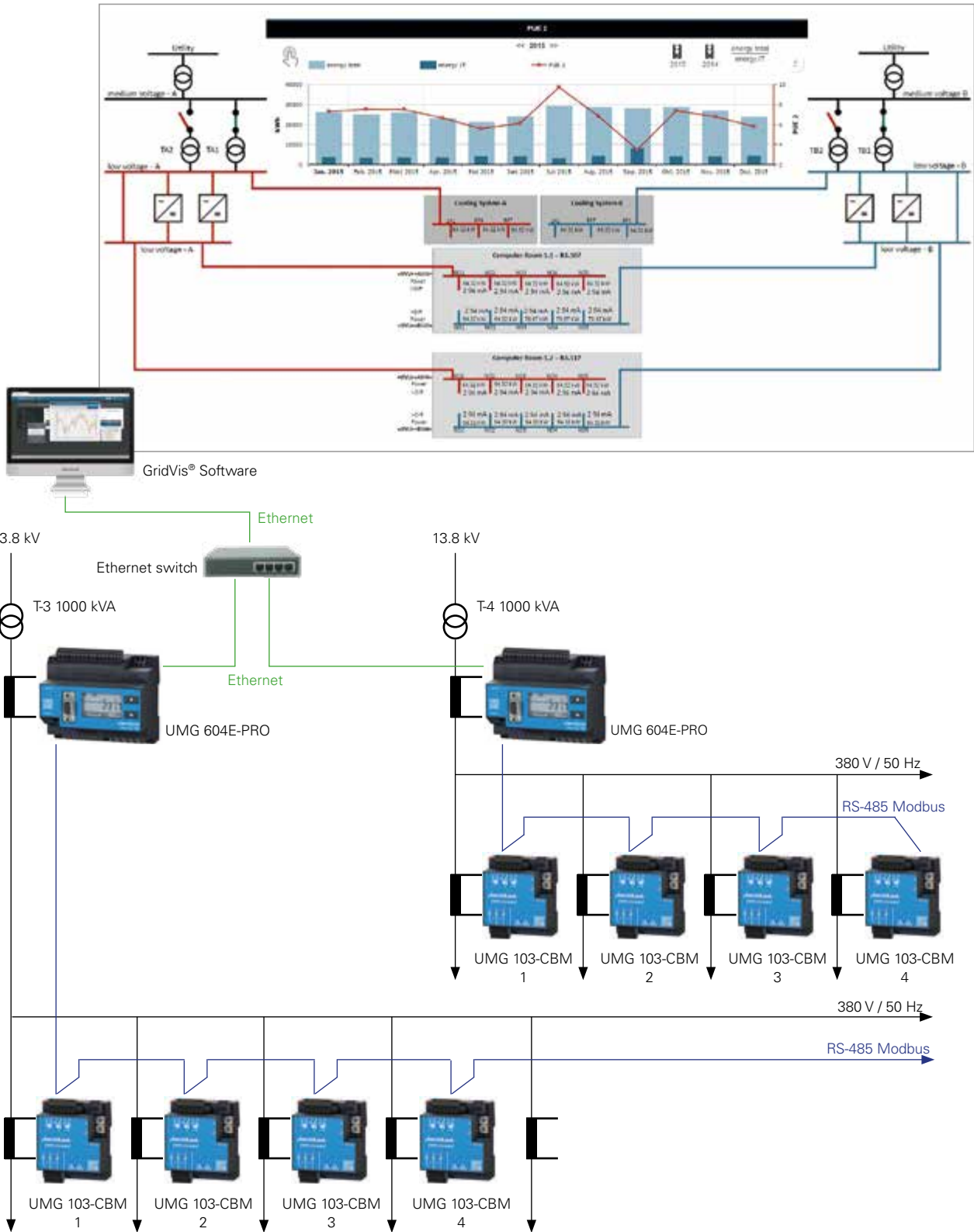

Fig.: Illustration of typical application with 2 feeders, UMG 604-PRO as master meters in the main feeder and UMG 103-CBM for measuring the low voltage outgoing feeders.

UMG 103-CBM – TECHNICAL DATA

UMG 103-CBM	
PART NUMBER	5228001
GENERAL	
Net weight (with attached plug-in connectors)	approx. 200 g (0.44 lbs)
Device dimensions (W x H x D)	71.5 x 98 x 46 mm (2.82 x 3.86 x 1.18 in)
ENVIRONMENTAL CONDITIONS DURING OPERATION	
The device is for weather-protected and stationary use. ... fulfills the operating conditions according to DIN IEC 60721-3-3 ... has protection class II according to IEC 60536 (VDE 0106, part 1) and ... does not require a ground wire connection.	
Working temperature range	-25 °C .. +60 °C (-13 °F..to 140 °F)
Relative humidity	5 to 95% (at +25 °C/77 °F), no condensation
Operating elevation	0 ... 2000 m above sea level
Pollution degree	2
Housing flammability classification	UL 94V-0
Mounting orientation	As desired
Ventilation	No forced ventilation required
Installation/assembly	DIN rail, 35 mm, to IEC/EN60999-1, DIN EN50022
Stress due to impact	2 joules, IK07 according to IEC/EN61010-1:2010
Protection against foreign matter and water	IP20 according to EN60529, September 2000, IEC60529:1989
MEASUREMENT DATA RECORDING	
Memory (flash)	4 MB
Battery (soldered), typical life expectancy	BR 1632, 3V, 8 - 10 years
TRANSPORT AND STORAGE	
The following information applies to devices that are transported or stored in their original packaging.	
Free fall	1 m (39.37 in)
Temperature	-20 °C ... +70 °C (68 °F ... 158 °F)
Relative humidity	0 to 90% RH
SUPPLY VOLTAGE (The device obtains the supply voltage from the measured voltage!)	
Supply from 1st phase	115 – 277 V (±10%), 50/60 Hz
Supply from 3 phases	80 – 277 V (±10%), 50/60 Hz
Power consumption	max. 1.5 VA
VOLTAGE MEASUREMENT	
3-phase 4-wire systems with nominal voltages (L-N/L-L)	max. 277 V/480 V
Networks	Measurement in TT and TN networks
Rated surge voltage	4 kV
Protection of the voltage measurement	1 – 10 A tripping characteristic B, (with IEC/UL approval)
Overvoltage category	300 V CAT III
Resolution	0.01 V
Crest factor	2 (relative to 240 Vrms)
Sampling frequency	5.4 kHz
Frequency of the fundamental oscillation	45 Hz ... 65 Hz
- Resolution	0.001 Hz
Fourier analysis	1st-40th Harmonics (all odd)

CURRENT MEASUREMENT

Nominal current	5 A
Rated current	6 A
Crest factor	2 (relative to 6 Arms)
Resolution	0.1 mA
Measuring range	0.005 .. 6 Arms
Overvoltage category	300 V CAT II
Rated surge voltage	2 kV
Power consumption	approx. 0.2 VA (Ri = 5 mΩ)
Overload for 1 s	60 A (sinusoidal)
Sampling frequency	5.4 kHz

TERMINAL CONNECTION CAPACITY

Connectible conductors. Only connect one conductor per terminal!

Single core, multi-core, fine-stranded	0.08 – 2.5 mm ² , AWG 28 - 12
Tightening torque	max. 0.5 Nm
Strip length	min. 8 mm

RS-485 INTERFACE

Protocol, Modbus RTU	Modbus RTU/Slave
Transmission rate	9.6 kbps, 19.2 kbps, 38.4 kbps, 57.6 kbps, 115.2 kbps automatic detection

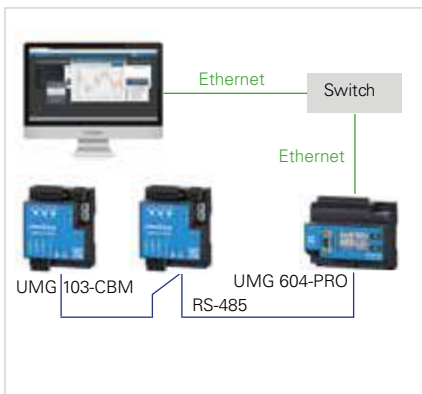

Fig.: Connection of several UMG 103-CBMs to a PC via a UMG 604-PRO (with Ethernet option)

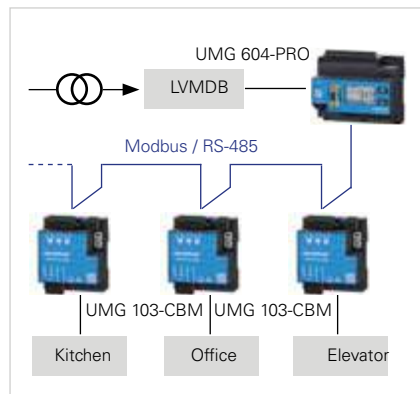

Fig.: Topology example for UMG 604-PRO (master) - UMG 103-CBM (slave)

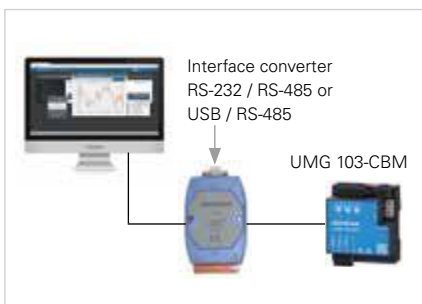
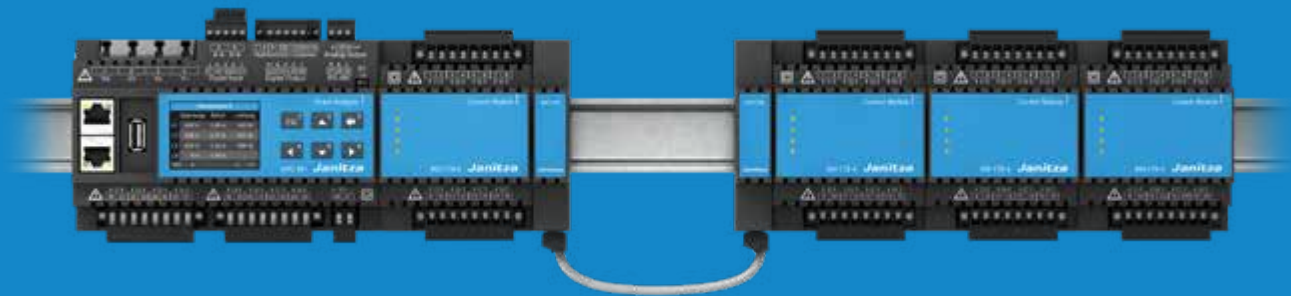

Fig.: Connection of a UMG 103-CBM to a PC via an interface converter

MODULARLY EXPANDABLE NETWORK ANALYZER



MODULARITY

- Expandable to 92 current measurement channels
- The modules can be mixed modules can be mixed with each other and maximum 10 module slots
- Measuring distance bridging up to 100 m

POWER QUALITY

- Event and transient detection
- Event browser
- Harmonics up to the 127th harmonic

MEASUREMENT DATA MEMORY

- 4 GB device-internal memory / no factory setting

COMMUNICATION

- Modbus RTU & gateway
- OPC UA
- NTP time synchronization

INTERFACES

- RS-485
- 2 x Ethernet

PERIPHERALS

- 4 digital inputs
- 4 digital outputs
- 1 analog output

MEASURING ACCURACY

- Class 0.2S
- Current: 0.2%
- Voltage: 0.2%

MULTIFUNCTION CHANNELS

- Flexible use
- Residual current detection
- Temperature measurement
- Current measurement

RESIDUAL CURRENT DETECTION

- Residual current measurement with open circuit detection

UMG 801

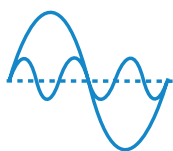

POWER QUALITY

Events and transients
for two feeders

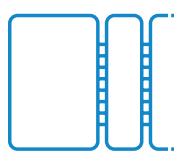

MODULAR

Modular expansion to up to
92 current measurement channels



COMMUNICATION

Future-proof communication
options with OPC UA

UMG 801 – DIMENSIONED DRAWING

All dimensions in mm

Rear view

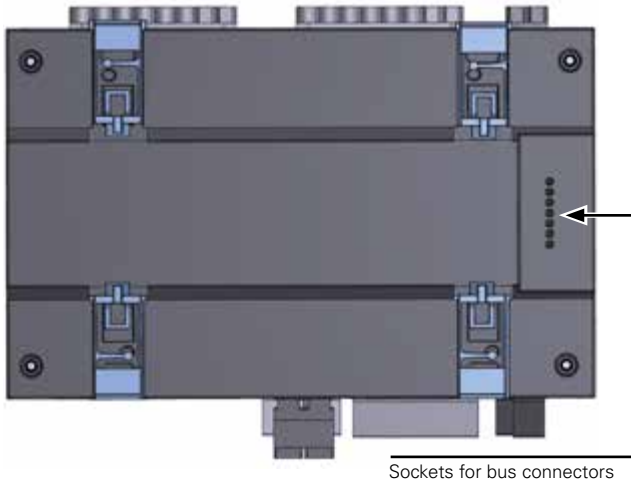

Bus connector

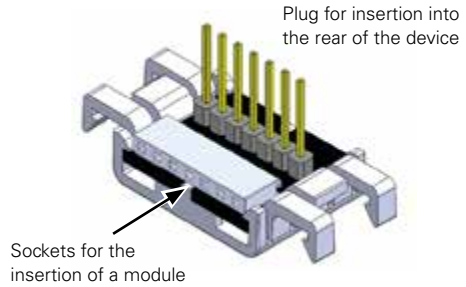

Bottom view

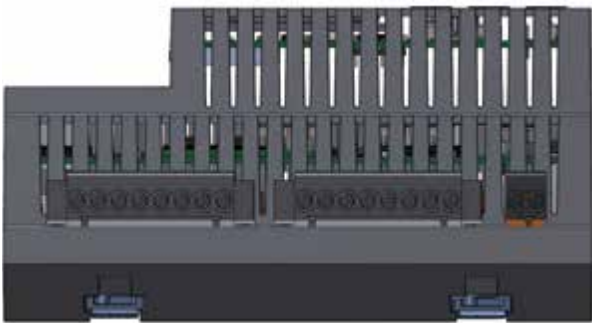

Top view

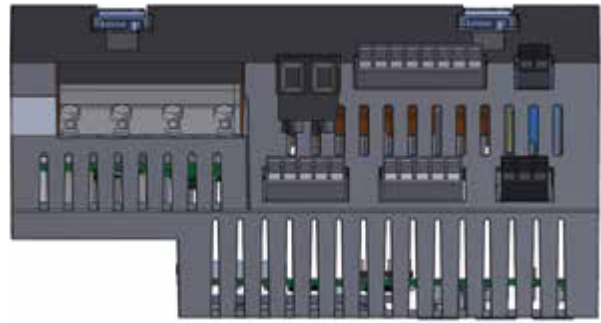

Front view



View from left

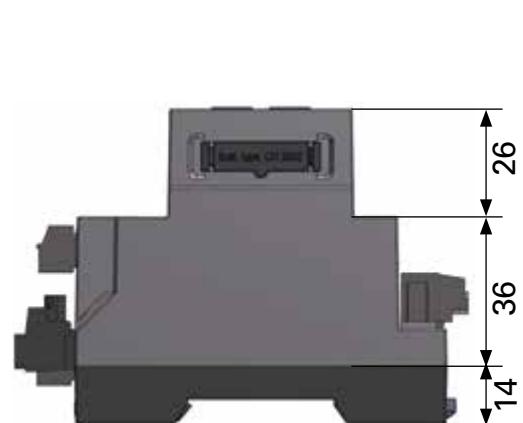

UMG 801 – CONNECTION EXAMPLE

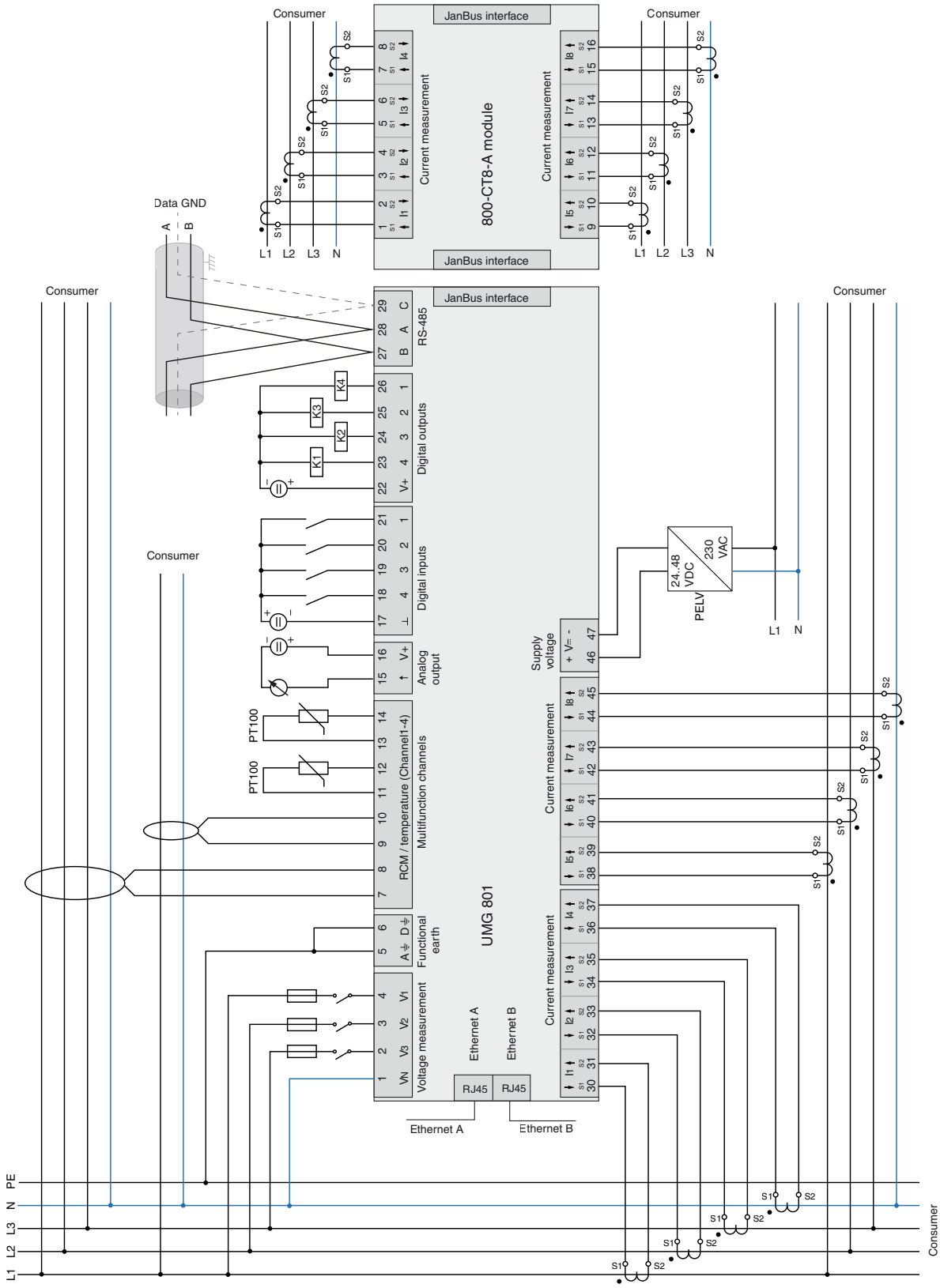

UMG 801 – TECHNICAL DATA

UMG 801 ^{*1}	
PART NUMBER	5231003
GENERAL	
Net weight	420 g (0.93 lb)
Device dimensions (W x H x D)	approx. 144 x 90 x 76 mm (5.67 x 3.54 x 2.99 in)
Battery	Type: Lithium CR2032, 3 V (UL1642 approval)
Integrated memory	4 GB
Backlight service life	40000 h (50% of the start brightness)
Mounting orientation	As desired
Fastening/mounting - suitable DIN rails - 35 mm (1.38 in)	TS 35/7.5 according to EN 60715 TS 35/10 TS 35/15 x 1.5
Impact resistance	IK07 according to IEC 62262
TRANSPORT AND STORAGE	
The following specifications apply for devices transported and stored in the original packaging.	
Free fall	1 m (39.37 in)
Temperature	-25 °C to +70 °C (-13 °F to 158 °F)
Relative humidity	5 to 95 % RH at 25 °C (77 °F), no condensation
ENVIRONMENTAL CONDITIONS DURING OPERATION	
The device:	
– is for weather-protected and stationary use.	
– fulfills operating conditions according to DIN IEC 60721-3-3.	
– Has protection class II according to IEC 60536 (VDE 0106, part 1), a ground wire connection is not required!	
Rated temperature range	-10 °C to +55 °C (14 °F to 131 °F)
Relative humidity	5 to 95 % at 25 °C (77 °F), no condensation
Operating elevation/overvoltage category	2000 m (6562 ft) above sea level Voltage measurement: 1000 V CAT III; 600 V CAT IV Current measurement: 300 V CAT II
	4000 m (13123 ft) above sea level Voltage measurement: 600 V CAT III; Current measurement: 300 V CAT II
Pollution degree	2
Ventilation	No forced ventilation required
Protection against foreign matter and water	IP20 according to EN60529
SUPPLY VOLTAGE	
Nominal range	DC: 24 V, PELV
Operating range	± 10% of nominal range
Power consumption	max. 4 W
Maximum power consumption with 10 modules	12 W (UMG 801 at 4 W plus 10 modules at 0.8 W each)
Recommended overcurrent protective device for line protection	2–6 A, (Char. B), IEC-/UL approval
*1 Separate power supply required, optionally available: Switching power supply UltraSlim, part no. 1605012 or switching power supply with stepped/circuit-breaker design, part no. 1605014	

VOLTAGE MEASUREMENT

3-phase 4-conductor systems with rated voltages up to	480 V _{LN} / 830 V _{LL} (± 10%) according to IEC 347 V _{LN} / 600 V _{LL} (± 10%) according to UL
3-phase 3-conductor systems (grounded) with rated voltages up to	830 VL-L (± 10%) according to IEC 600 VL-L (± 10%) according to UL
3-phase 3-conductor systems (non-grounded) with rated voltages up to	690 VL-L (± 10%) according to IEC 600 VL-L (± 10%) according to UL
Oversvoltage category	1000 V CAT III according to IEC 600 V CAT III according to UL
Rated surge voltage	8 kV
Protection of the voltage measurement	1–10 A tripping characteristic B (with IEC/UL approval)
Measuring range L-N	0 ¹⁾ ... 720 Vrms (max. oversvoltage 1000 Vrms)
Measuring range L-L	0 ¹⁾ ... 1000 Vrms (max. oversvoltage 1000 Vrms)
Measuring range N-PE	up to 100 V
Resolution	16 bit
Crest factor	1.6 (referred to measuring range 600 V L-N)
Impedance	4 MΩ/phase
Power consumption	approx. 0.1 VA
Sampling frequency	51.2 kHz
Frequency of fundamental oscillation	40 Hz ... 70 Hz
– Resolution	0.01 Hz
Harmonics	1 ... 127.

1) ... The device only measures if at least one voltage measurement input has an L-N voltage of > 10 Vrms or an L-L voltage of > 18 Vrms applied.

CURRENT MEASUREMENT (.../1 A) (.../5 A)

Nominal current	5 A
Channels	8 2 systems – L1, L2, L3, N (optional) Single channels
Measuring range	0.005 ... 6 Aeff
Crest factor (relative to nominal current)	1.98
Overload for 1 s	120 A (sinusoidal)
Resolution	0.1 mA (color graphic display 0.01 A)
Oversvoltage category	300 V CAT II
Rated surge voltage	2.5 kV
Power consumption	approx. 0.2 VA (Ri = 5 mΩ)
Sampling frequency	25.6 kHz
Harmonics	1 ... 63th

RESIDUAL CURRENT MEASUREMENT (RCM)

Nominal current	30 mAeff
Measuring range	0 ... 40 mAeff
Operating current	50 μA
Resolution	1 μA (color graphic display 0.01 A)
Crest factor	1.414 (relative to 40 mA)
Load	4 Ω
Overload for 20 ms	50 A
Overload for 1 s	5 A
Permanent overload	1 A
Norm	IEC/TR 60755 (2008-01), Typ A + Typ B and B+ (via corresponding current transformers)

TEMPERATURE MEASUREMENT

Update time	1 s
Total load (sensor and cable)	max. 4 k Ω
Cable	Up to 30 m (32.81 yd) not shielded Greater than 30 m (32.81 yd) shielded
Suitable sensor types	KTY83, KTY84, PT100, PT1000

DIGITAL INPUTS

4 digital inputs, solid state relays, not short-circuit proof.

Maximum counter frequency	20 Hz
Input signal applied	18 ... 28 V DC (typically 4 mA)
Input signal not applied	0 ... 5 V DC, current less than 0.5 mA

DIGITAL OUTPUTS

4 digital outputs, solid state relays, not short-circuit proof.

Switching voltage	Max. 60 V DC
Switching current	max. 50 mA _{eff} DC
Response time	approx. 500 ms
Digital output (energy pulses)	max. 20 Hz

CABLE LENGTH (DIGITAL INPUTS/OUTPUTS)

Up to 30 m (32.81 yd)	Unshielded
Greater than 30 m (32.81 yd)	Shielded

ANALOG OUTPUTS

1 channel

External power supply	max. 33 V DC
Current	0/4...20 mA DC
Update time	0.2 s
Load	max. 300 Ω
Resolution	10 bit

RS-485 INTERFACE

3-conductor connection with A, B, GND

Protocol	Modbus RTU/Slave Modbus RTU/Gateway
Transmission rate	9.6 kbps, 19.2 kbps, 38.4 kbps, 57.6 kbps, 115.2 kbps
Termination	DIP switches

ETHERNET INTERFACES

Connection	2 x RJ45
Function	Modbus gateway
Protocols, services and time synchronization	OPC UA, DHCP, Modbus/TCP, NTP
Time synchronization	NTP

CONNECTION CAPACITY OF THE TERMINALS (SUPPLY VOLTAGE)

Connectible conductors. Only connect one conductor per terminal!

Single core, multi-core, fine-stranded	0.2 – 2.5 mm ² , AWG 26–12
Wire ferrules (non-insulated) – recommended stripping length	0.2 – 2.5 mm ² , AWG 26–12 – 10 mm (0.3937 in)
Wire ferrules (insulated) – recommended stripping length	0.2 – 2.5 mm ² , AWG 26–12 – 13 mm (0.5118 in)
Wire ferrules: Length of the contact sleeve	10 mm (0.3937 in)

CONNECTION CAPACITY OF THE TERMINALS (CURRENT MEASUREMENT)

Connectible conductors. Only connect one conductor per terminal!

Single core, multi-core, fine-stranded	0.2 - 2.5 mm ² , AWG 26-12
Wire ferrules (non-insulated) – recommended stripping length	0.2 - 2.5 mm ² , AWG 26-12 – 10 mm (0.3937 in)
Wire ferrules (insulated) – recommended stripping length	0.2 - 2.5 mm ² , AWG 26-12 – 13 mm (0.5118 in)
Screw flange tightening torque	0.2 Nm (1.77 lbf in)
Wire ferrules: Length of the contact sleeve	10 mm (0.3937 in)

CONNECTION CAPACITY OF THE TERMINALS (VOLTAGE MEASUREMENT)

Connectible conductors. Only connect one conductor per terminal!

Single core, multi-core, fine-stranded	0.08 – 4.0 mm ² , AWG 28–12
Wire ferrules (insulated/non-insulated)	0.25 – 2.5 mm ² , AWG 24–14
Strip length	8 – 9 mm (0.3150 – 0.3543 in)

CONNECTION CAPACITY OF THE TERMINALS (FUNCTIONAL EARTH A/D)

Connectible conductors. Only connect one conductor per terminal!

Single core, multi-core, fine-stranded	0.2 – 4.0 mm ² , AWG 24–12
Wire ferrules (non-insulated)	0.2 – 4.0 mm ² , AWG 24–12
Wire ferrules (insulated)	0.2 – 2.5 mm ² , AWG 26–14
Tightening torque	0.4 – 0.5 Nm (3.54 – 4.43 lbf in)
Strip length	7 mm (0.2756 in)

CONNECTION CAPACITY OF THE TERMINALS - MULTIFUNCTION CHANNELS (RCM, TEMP.)

Connectible conductors. Only connect one conductor per terminal!

Single core, multi-core, fine-stranded	0.2 – 1.5 mm ² , AWG 24–16
Wire ferrules (non-insulated)	0.2 – 1.5 mm ² , AWG 26–16
Wire ferrules (insulated)	0.2 – 1 mm ² , AWG 26–18
Tightening torque	0.2 – 0.25 Nm (1.77 – 2.21 lbf in)
Strip length	7 mm (0.2756 in)

CONNECTION CAPACITY OF THE TERMINALS (DIGITAL INPUTS/OUTPUTS, ANALOG OUTPUT)

Single core, multi-core, fine-stranded	0.2 – 1.5 mm ² , AWG 24–16
Wire ferrules (non-insulated)	0.2 – 1.5 mm ² , AWG 26–16
Wire ferrules (insulated)	0.2 – 1 mm ² , AWG 26–18
Tightening torque	0.2 – 0.25 Nm (1.77 – 2.21 lbf in)
Strip length	7 mm (0.2756 in)

CONNECTION CAPACITY OF THE TERMINALS (RS-485)

Single core, multi-core, fine-stranded	0.2 – 1.5 mm ² , AWG 24–16
Wire ferrules (non-insulated)	0.2 – 1.5 mm ² , AWG 26–16
Wire ferrules (insulated)	0.2 – 1 mm ² , AWG 26–18
Tightening torque	0.2 – 0.25 Nm (1.77 – 2.21 lbf in)
Strip length	7 mm (0.2756 in)

MODULAR EXPANSIONS FOR THE UMG 801 METER

Module combinations

- The UMG 801 basic unit allows the connection of modules for measuring channel expansion
- The modules can be combined with each other
- The number of modules that can be connected is limited to 10 capacity units (so-called module slots)
- With the help of the corresponding modules, the basic unit can be expanded to up to 92 current measuring channels or 144 digital inputs

Possible connections of the modules

- 4 x 800-DI14 + 6 x 800-CT8-A + 2 x 800-CON = 10 module slots
- 3 x 800-CT8-A + 7 x 800-DI14 = 10 module slots
- 5 x 800-CT8-A = 5 module slots

800-CT8-A module

- Uses 1 module slot
- Easy connection thanks to plug & play
- Expand to up to 92 current measurement channels
- Compact design

800-CON module

- Uses 0 module slots
- Measuring distance bridging up to 100 m
- Simple connection via plug & play
- Optimal use of available space

UMG 801: 145 mm x 90 mm x 76 mm*



800-DI14 module

- Uses 1 module slot
- Expansion by up to 144 digital inputs
- Compact 1 TE design
- Accommodates, for example, door contacts, fans or switch positions for visualisation in GridVis or third-party systems
- Simple connection thanks to Plug & Play

RD 96

- Uses 0 module slots
- Remote display
- Operation of the UMG 801 and all modules via front panel
- Fast & easy connection



800-CT8-A module: 73 mm x 90 mm x 76 mm*

* Dimensions: Width x height x depth

MODULE 800-CT8-A – DIMENSIONED DRAWING

All dimensions in mm

Front view

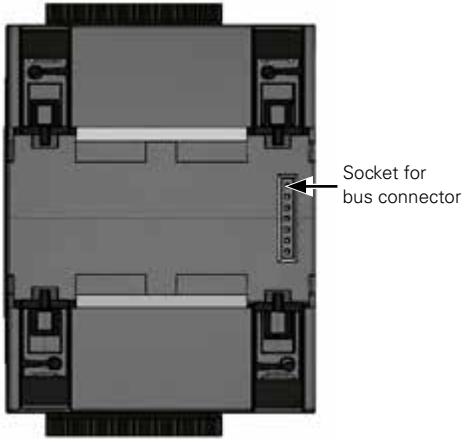

Side view

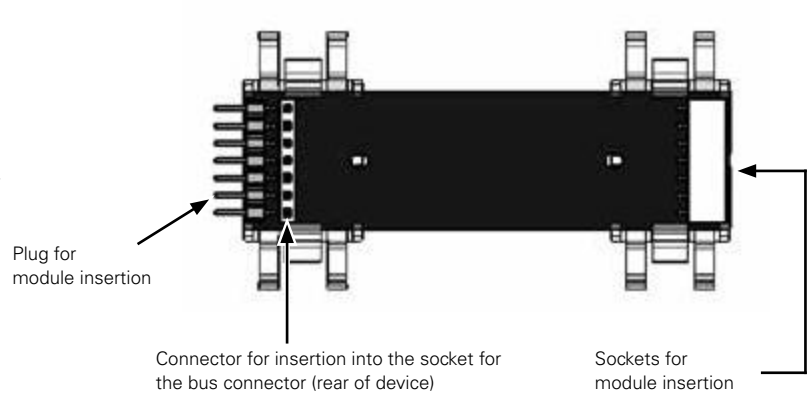

Bottom view

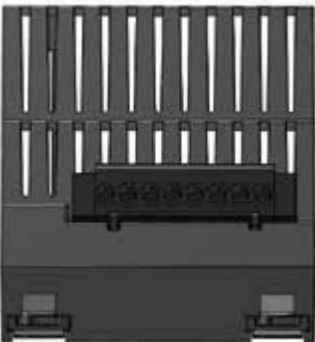

Top view

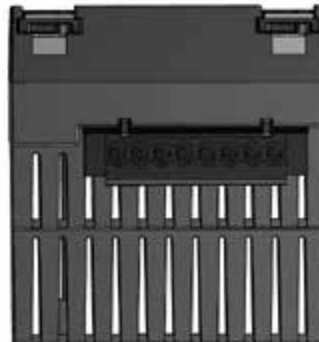

Front view

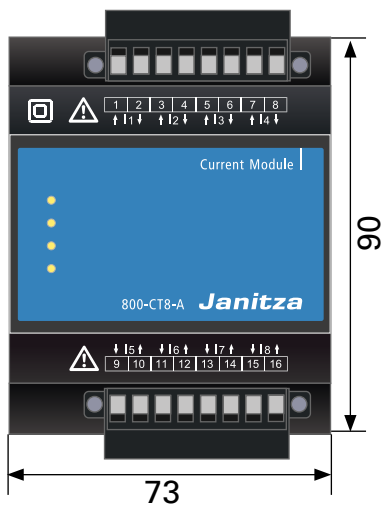

View from left

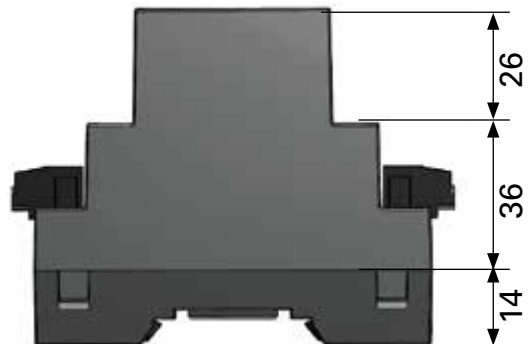

MODULE 800-CT8-A – TECHNICAL DATA

800-CT8-A MODULE	
PART NUMBER	5231230

GENERAL

Net weight	approx. 220 g (0.49 lbs)
Device dimensions (W x H x D)	approx. 72 x 90 x 76 mm (2.83 x 3.54 x 2.99 in)
Mounting orientation	As desired
Fastening/mounting - suitable DIN rails (35 mm / 1.38 in)	TS 35/7.5 according to EN 60715 TS 35/10 TS 35/15 x 1.5
Impact resistance	IK07 according to IEC 62262

TRANSPORT AND STORAGE

The following specifications apply for devices transported and stored in the original packaging

Free fall	1 m (39.37 in)
Temperature	K55: -25° C to +70° C (-13 °F ..to 158 °F)
Relative humidity	5 to 95% at 25 °C (77 °F), no condensation

ENVIRONMENTAL CONDITIONS DURING OPERATION

The device:

- is for weather-protected and stationary use.
- fulfills operating conditions according to DIN IEC 60721-3-3.
- Has protection class II according to IEC 60536 (VDE 0106, part 1), a ground wire connection is not required!

Rated temperature range	-10 °C to +55 °C (14 °F to 131 °F)
Relative humidity	5 to 95% at 25 °C (77 °F), no condensation
Pollution degree	2
Ventilation	No forced ventilation required
Protection against foreign matter and water	IP20 according to EN60529

INTERFACE AND ENERGY SUPPLY

JanBus (proprietary)	- Via bus connector - The maximum bus length of the JanBus is 100 m.
----------------------	---

CURRENT MEASURING MODULE 800-CT8-A

Nominal current	5 A
Channels	2 systems (L1, L2, L3, N) Single channels
Measuring range	0.005 .. 6 A
Crest factor	2 (relative to 6 A _{eff})
Overload for 1 s	120 A (sinusoidal)
Resolution	0.1 mA (color graphic display 0.01 A)
Overvoltage category	300 V CAT II
Rated surge voltage	2.5 kV
Power consumption	approx. 0.2 VA (R _i = 5 mΩ)
Sampling frequency	8.3 kHz
Frequency of the fundamental oscillation	40 Hz ... 70 Hz
Harmonics	1 ... 9 (odd only)

CONNECTION CAPACITY OF THE TERMINALS (CURRENT MEASUREMENT) – MODULE 800-CT8-A

Connectible conductors. Only connect one conductor per terminal!

Single core, multi-core, fine-stranded	0.2 – 2.5 mm ² , AWG 26–12
Wire ferrules (non-insulated) – recommended stripping length	0.2 – 2.5 mm ² , AWG 26–12 – 10 mm (0.3937 in)
Wire ferrules (insulated) – recommended stripping length	0.2 – 2.5 mm ² , AWG 26–12 – 13 mm (0.5118 in)
Screw flange tightening torque	0.2 Nm (1.77 lbf in)
Wire ferrules: Length of the contact sleeve	10 mm (0.3937 in)

MODULE 800-CON – DIMENSIONED DRAWING

All dimensions in mm

Rear view

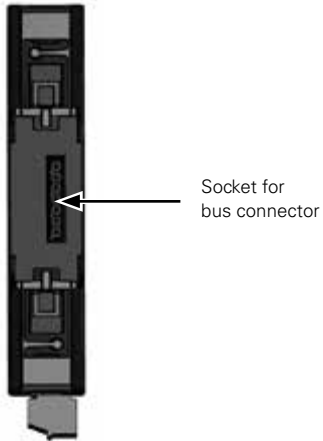

Bus connector for transfer module – Output

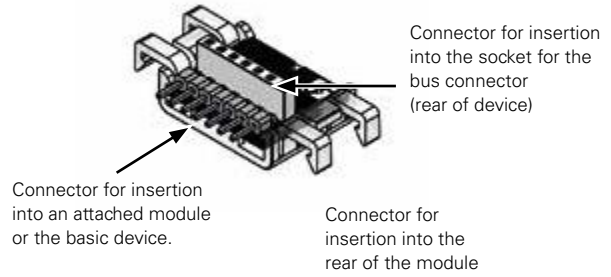

Bottom view



Top view



Bus connector for transfer module - Input

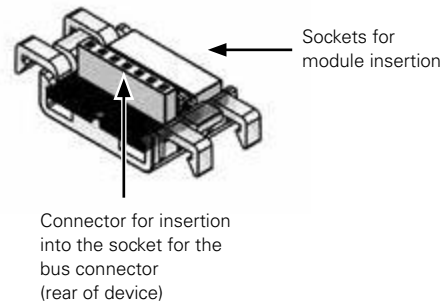

Front view

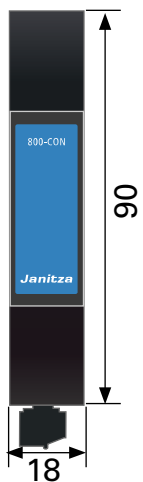

View from left

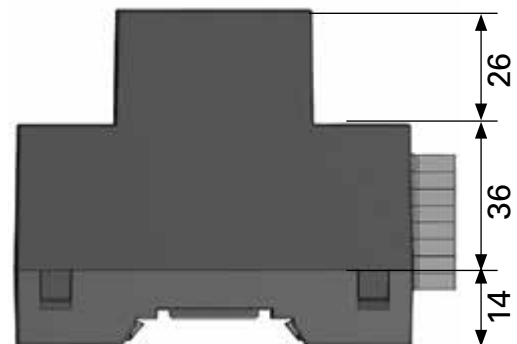

MODULE 800-CON – TECHNICAL DATA

MODULE 800-CON*1	
PART NUMBER	5231210
GENERAL	
Net weight (with plug-in terminals)	approx. 55 g (0.12 lb) – 1 device
Device dimensions (W x H x D)	approx. 18 x 90 x 76 mm (0.71 x 3.54 x 2.99 in)
Mounting orientation	As desired
Fastening/mounting - suitable DIN rails (35 mm)	TS 35/7.5 according to EN 60715 TS 35/10 TS 35/15 x 1.5
Impact resistance	IK07 according to IEC 62262
TRANSPORT AND STORAGE	
The following specifications apply for devices transported and stored in the original packaging	
Free fall	1 m (39.37 in)
Temperature	K55: -25° C to +70° C (-13 °F ..to 158 °F)
Relative humidity	5 to 95% at 25 °C (77 °F), no condensation
ENVIRONMENTAL CONDITIONS DURING OPERATION	
The device: – is for weather-protected and stationary use. – fulfills operating conditions according to DIN IEC 60721-3-3. – has protection class II according to IEC 60536 (VDE 0106, part 1), a ground wire connection is not required!	
Rated temperature range	-10 °C to +55 °C (14 °F to 131 °F)
Relative humidity	5 to 95% at 25 °C (77 °F), no condensation
Pollution degree	2
Ventilation	No forced ventilation required
Protection against foreign matter and water	IP20 according to EN60529
INTERFACE	
JanBus (proprietary)	– Via bus connector to device and module series
NOTE! To connect the transfer modules, use a twisted pair, stranded, shielded data cable (cable connection 1:1)!	– Via shield clamps between the transfer modules with twisted pair, shielded data cable (cable connection 1:1) – The maximum bus length of the JanBus is 100 m.
TERMINAL CONNECTION CAPACITY	
Connectible conductors. Only connect one conductor per terminal!	
Single core, multi-core, fine-stranded	0.2–1.5 mm ² , AWG 24–16
Wire ferrules (non-insulated)	0.2–1.5 mm ² , AWG 26–16
Wire ferrules (insulated)	0.2–1 mm ² , AWG 26–18
Tightening torque	0.2–0.25 Nm (1.77 – 2.21 lbf in)
Strip length	7 mm (0.2756 in)

MODULE 800-DI14 – DIMENSIONED DRAWING

All dimensions in mm

Rear view

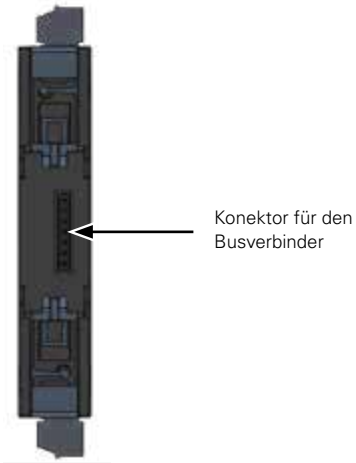

Bottom view



Top view



Communication bus connector to module 800-DI14

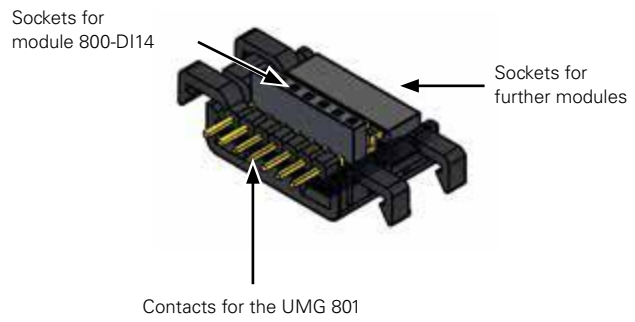

Front view

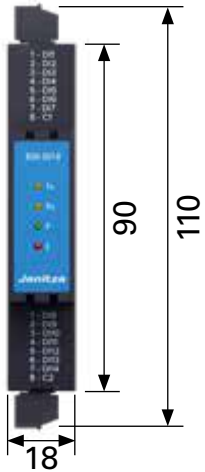

View from left

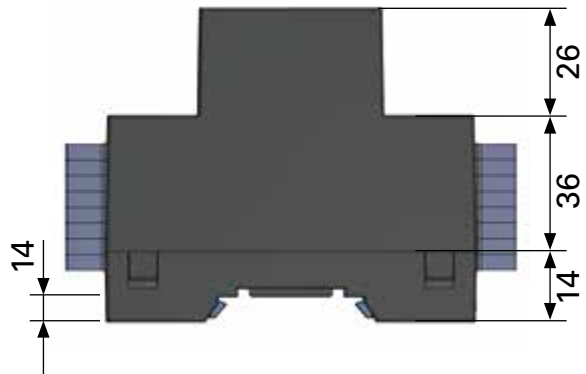

MODULE 800-DI14 – TECHNICAL DATA

MODUL 800-DI14	
PART NUMBER	5231214
GENERAL	
Net weight (with plug-in terminals)	approx. 73 g (0.16 lb) –1 Gerät
Device dimensions (W x H x D)	approx. 18 x 90 x 76 mm (0.71 x 3.54 x 2.99 in)
Mounting orientation	As desired
Fastening/mounting - suitable DIN rails (35 mm)	TS 35/7,5 according to EN 60715 TS 35/10 TS 35/15 x 1,5
Impact resistance	IK07 according to IEC 62262
TRANSPORT AND STORAGE	
The following specifications apply for devices transported and stored in the original packaging	
Free fall	1 m (39.37 in)
Temperature	K55: -25 °C (-13 °F) to +70 °C (158 °F)
Relative humidity	0 to 95% at 25 °C (77 °F), no condensation
ENVIRONMENTAL CONDITIONS DURING OPERATION	
The device:	
– weather-protected and stationary.	
– Meets operating conditions according to DIN IEC 60721-3-3.	
– Has protection class II according to IEC 60536 (VDE 0106, part 1), a protective earth connection is not required!	
Rated temperature range	-10 °C (14 °F to +55 °C (131 °F)
Relative humidity	5 to 95% at 25 °C (77 °F), no condensation
Pollution degree	2
Ventilation	No forced ventilation required
Protection against foreign matter and water	IP20 according to EN60529
DIGITAL INPUTS	
14 digital inputs, solid state relays, not short-circuit proof	
Maximum counter frequency	20 Hz
Input signal is present	18 .. 28 V DC (typically 4 mA)
Input signal is not present	0 .. 5 V DC, Strom kleiner 0,5 mA
SCHNITTSTELLE	
JanBus	– via bus connector
TERMINAL CONNECTION CAPACITY	
Connectible conductors. Only connect one conductor per terminal!	
Single core, multi-core, fine-stranded	0.2 – 1.5 mm ² , AWG 24-16
Wire ferrules (non-insulated)	0.2 – 1.5 mm ² , AWG 26-16
Wire ferrules (insulated)	0.2 – 1 mm ² , AWG 26-18
Tightening torque	0.2 – 0.25 Nm (1.77 – 2.21 lbf in)
Strip length	7 mm (0.2756 in)

RD 96 – DIMENSIONED DRAWING

Front view



Side view

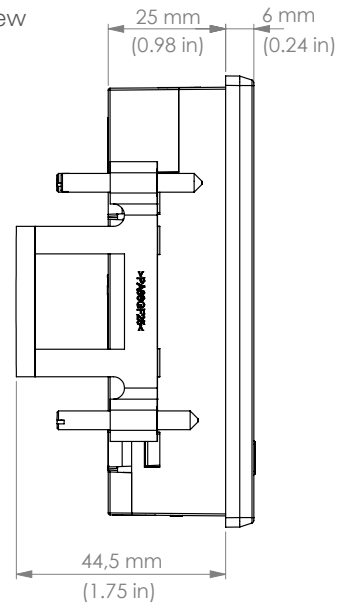

Front view

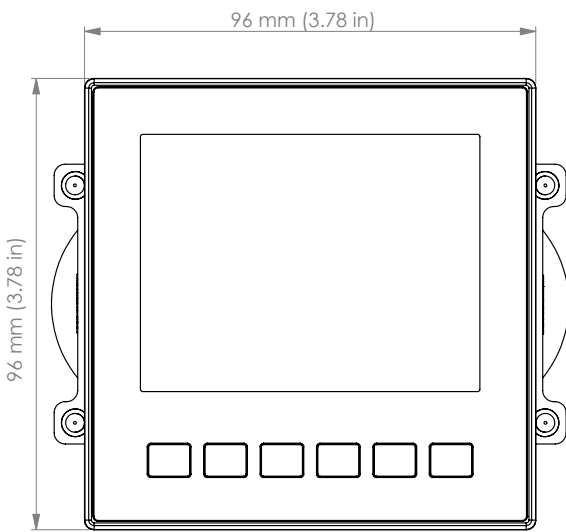

Rear view

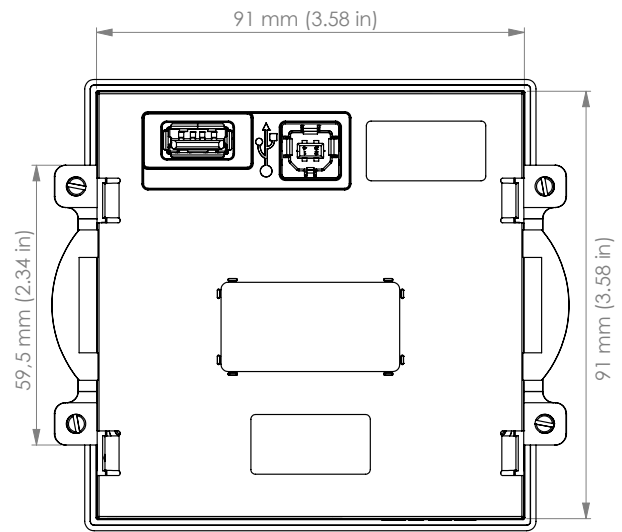

Top view

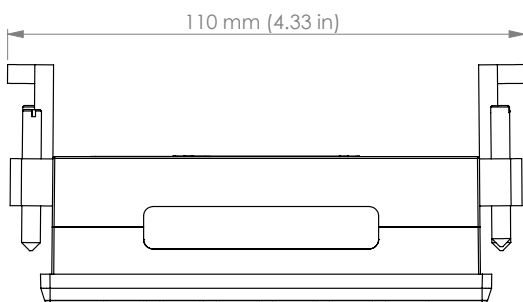

Bottom view

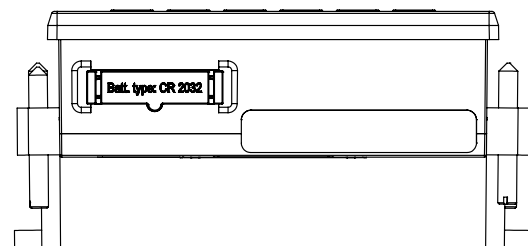

RD 96 – TECHNICAL DATA

	RD 96*1
PART NUMBER	5231212

GENERAL

Net weight	approx. 140 g (0.31 lbs)
Package weight (incl. accessories)	approx. 440 g (0.97 lbs)
Dimensions W x H x D without mounting clamps	96 mm x 96 mm x 30 mm(3.78 in x 3.78 in x 1.18 in)
Backlight service life	40000 h (after 40000 h the backlight goes down to approx. 50%)
Impact resistance	IK07 according to IEC 62262

SERIAL INTERFACE (USB)

USB 2.0 (type A)	1x
USB 2.0 (type B)	1x
Supply voltage	DC 5 V
Nominal current	200 mA
Operating range	± 5% of nominal range
Power consumption	1 W

TRANSPORT AND STORAGE

The following specifications apply for devices transported and stored in the original packaging.

Free fall	1 m (39.37 in)
Temperature	-25° C (-13 °F) to +70° C (158 °F)
Relative air humidity (non-condensing)	0 to 90% RH

ENVIRONMENTAL CONDITIONS DURING OPERATION

The device:

- is for weather-protected and stationary use.
- Protection class II according to IEC 60536 (VDE 0106, Part 1).

Rated temperature range	-10 °C (14 °F) to +55 °C (131 °F)
Relative air humidity (non-condensing)	0 to 75% RH
Operating elevation	0 – 2000 m (6562 ft) above sea level
Pollution degree	2
Mounting orientation	As desired
Ventilation	No forced ventilation required
Protection against foreign matter and water	
- Front	IP40 according to EN60529
- Rear	IP20 according to EN60529
- Front with seal	IP54 according to EN60529

USB CABLE

(included in delivery)

USB 2.0 (type A to type B connector)	1.8 m (1.97 yd)
--------------------------------------	-----------------

*1 The USB cable is included in the scope of delivery. The RD 96 works exclusively with the UMG 801.

FUNCTIONALLY EXPANDABLE NETWORK ANALYZER

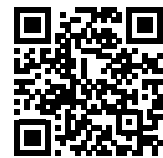

INTERFACES

- Ethernet
- RS-232
- RS-485

PERIPHERALS

- Digital inputs and outputs
e.g. pulse input
- State monitoring
and limit value output
- Thermistor input

ENERGY MANAGEMENT

- Peak load optimization (optional)
- Up to 64 switch-off stages

PROGRAMMABLE

- PLC functionality
- Jasic®
- APPs from the Janitza library

DEVICE HOMEPAGE

- Online & historical data
- Graphs available directly on
homepage

MEASURING ACCURACY

- Class 0.2S
- Sampling frequency 20 kHz

MEASUREMENT DATA MEMORY

- 128 MB / approx. 47.97 months
(according to factory setting)
- Record range up to 2 years

POWER QUALITY

- Harmonics current up to the
40th harmonic
- Events and transients
- Unbalance
- Full wave RMS recording

UMG 604-PRO

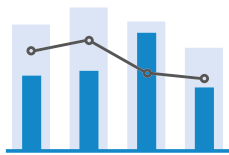

ENERGY MANAGEMENT

Energy data acquisition with power quality analysis



COMMUNICATION

Integrated Modbus gateway for integration of devices (energy meters)

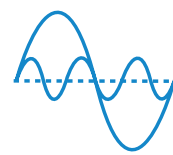

POWER QUALITY

Capture of events and transients

UMG 604-PRO – DIMENSIONED DRAWING

All dimensions in mm

Front view

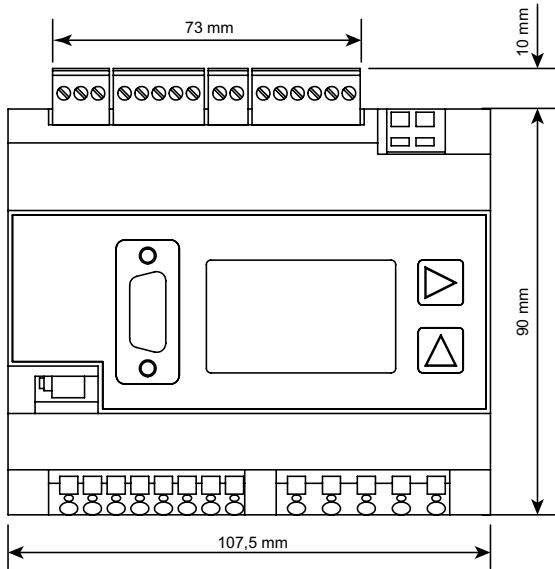

Side view

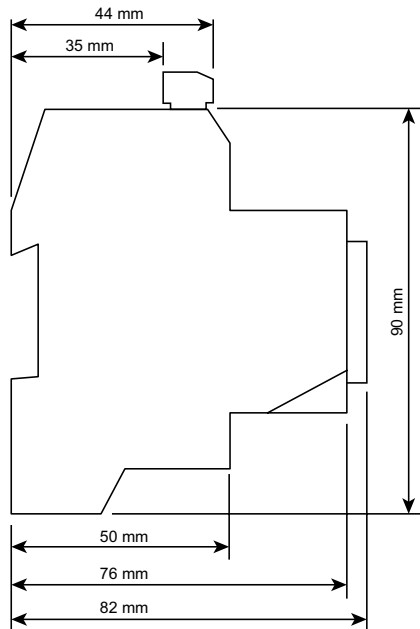

UMG 604-PRO- CONNECTION EXAMPLE

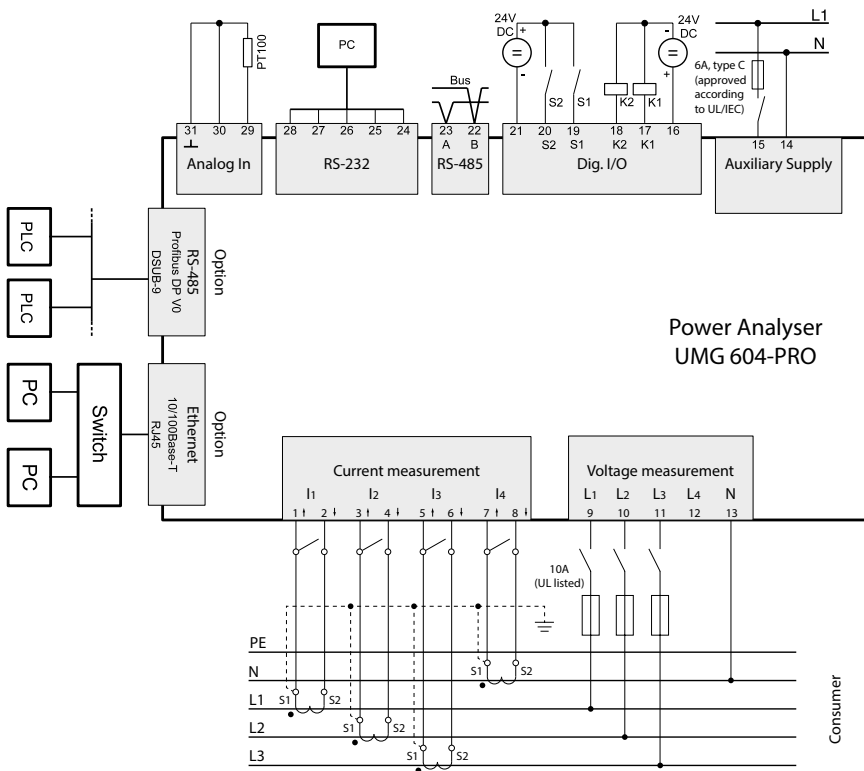

UMG 604-PRO – TECHNICAL DATA

	UMG 604E-PRO			UMG 604EP-PRO	
PART NUMBER	5216012				
PART NUMBER (UL)	5216202	–	5216222	5216201	5216221
Supply voltage, AC	95 ... 240 VAC	50 ... 110 V AC	20 ... 50 VAC	95 ... 240 VAC	20 ... 50 VAC
Supply voltage, DC	135 ... 340 V DC	50 ... 155 VDC	20 ... 70 V DC	135 ... 340 V DC	20 ... 70 V DC
INTERFACES					
RS-485: 9.6 – 921.6 kbps (pluggable screw terminal)	•	•	•	•	•
RS-232: 9.6 – 115.2 kbps (pluggable screw terminal)	•	•	•	•	•
Profibus DP: up to 12 Mbps (DSUB-9 plug)	–	–	–	•	•
Ethernet 10/100 base TX (RJ-45 socket)	•	•	•	•	•
PROTOCOLS					
Modbus RTU, Modbus TCP, Modbus RTU over Ethernet	•	•	•	•	•
Modbus gateway for master-slave configuration	•	•	•	•	•
Profibus DP V0	–	–	–	•	•
HTTP (homepage configurable)	•	•	•	•	•
SMTP (email)	•	•	•	•	•
NTP (time synchronization)	•	•	•	•	•
TFTP (automatic configuration)	•	•	•	•	•
FTP (file transfer)	•	•	•	•	•
SNMP	•	•	•	•	•
DHCP	•	•	•	•	•
TCP/IP	•	•	•	•	•
BACnet (optional)	•	•	•	•	•
ICMP (ping)					
DEVICE OPTIONS					
BACnet communication	5216081	5216081	5216081	5216081	5216081

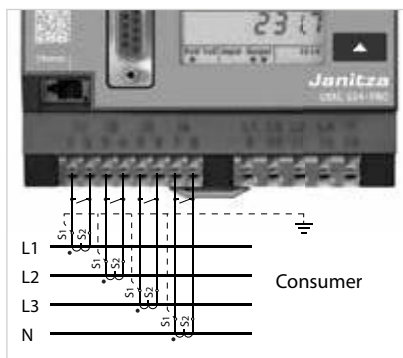

Fig.: Current measurement via current transformers

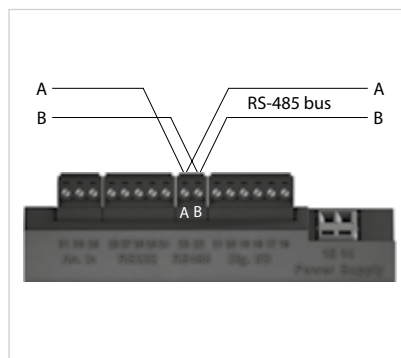

Fig.: RS-485 interface, 2-pole plug contact



Fig.: Example thermistor input (KTY83) and S0 pulse generator

UMG 604-PRO – TECHNICAL DATA

GENERAL

Net weight	350 g (0.77 lb)
Device dimensions in mm (W x H x D)	approx. 90 x 82 x 107.5 mm (3.54 x 3.62 x 4.23 in) (according to DIN 43871:1992)
Housing flammability classification	UL 94V-0
Mounting orientation	As desired
Installation/assembly	DIN rail 35 mm (according to IEC/EN60999-1, DIN EN 50022)
Battery	Type, lithium CR2032, 3 V (approval according to UL 1642)
Backlight service life (option)	40000 h (50% of the start brightness)

ENVIRONMENTAL CONDITIONS

The device ...
... is for weather-protected and stationary use.
– fulfills operating conditions according to DIN IEC 60721-3-3.

Working temperature range	-10 °C ... +55 °C (14 °F..to 131 °F)
Relative humidity	5 to 95%, (at +25 °C/77 °F), no condensation
Pollution degree	2
Operating elevation	0 ... 2000 m above sea level
Mounting orientation	As desired
Ventilation	forced ventilation is not required.

TRANSPORT AND STORAGE

The following information applies to devices that are transported or stored in their original packaging.

Free fall	1 m
Temperature	-20 °C to +70 °C (-4 °F..to 158 °F)

SUPPLY VOLTAGE

The supply voltage must be connected to the device via a UL/IEC approved fuse (6A Char. B).

Option 230 V:	
Nominal range	95 V ... 240 V (50/60 Hz) / DC 135 V ... 340 V
Operating range	±10% of nominal range
Power consumption	max. 3.2 W / 9 VA
Overvoltage category	300 V CAT II
Option 90 V (without UL approval):	
Nominal range	50 V ... 110 V (50/60 Hz) / DC 50 V ... 155 V
Operating range	±10% of nominal range
Power consumption	max. 3.2 W / 9 VA
Overvoltage category	300 V CAT II
Option 24 V:	
Nominal range	20 V ... 50 V (50/60 Hz) / DC 20 V ... 70 V
Operating range	±10% of nominal range
Power consumption	max. 5 W / 8 VA
Overvoltage category	150 V CAT II

CONNECTION CAPACITY OF THE TERMINALS (SUPPLY VOLTAGE)

Connectible conductors. Only one conductor may be connected per terminal!

Single core, multi-core, fine-stranded	0.08 – 2.5 mm ² , AWG 28-12
Wire ferrules (non-insulated)	0.20 – 1.5 mm ² , AWG 24-16
Wire ferrules (insulated)	0.25 – 1.5 mm ² , AWG 24-16
Strip length	5 – 6 mm (0.2 – 0.24 in)

PROTECTION CLASS

Protection class II according to IEC 60536 (VDE 0106, Part 1), no ground wire connection is required!

Protection against foreign matter and water	IP20 according to EN60529, September 2014, IEC60529:2013
---	--

DIGITAL INPUTS

Maximum counter frequency (pulse input S0)	20 Hz
--	-------

Switching input

Input signal applied	18 V ... 28 VDC (typically 4 mA)
Input signal not applied	0 ... 5 VDC, current less than 0.5 mA
Response time (Jasic program)	200 ms
Line length	up to 30 m not shielded; greater than 30 m shielded

DIGITAL OUTPUTS (2 digital outputs; solid state relays, not short-circuit proof)

Switching voltage	max. 60 VDC, 30 VAC
Switching current	max. 50 mAeff AC/DC
Response time (Jasic program)	200 ms
Output of voltage dips	20 ms
Output of voltage surges	20 ms
Switching frequency	max. 20 Hz
Line length	up to 30 m not shielded; greater than 30 m shielded

CONNECTION CAPACITY OF THE TERMINALS (DIGITAL INPUTS AND OUTPUTS)

Connectible conductors. Only one conductor may be connected per terminal!

Single core, multi-core, fine-stranded	0.2 – 1.5 mm ² , AWG 24-16
Wire ferrules (non-insulated)	0.2 – 1.5 mm ² , AWG 24-16
Wire ferrules (insulated)	0.2 – 1.0 mm ² , AWG 24-18
Tightening torque	0.25 Nm (1.77 – 2.21 lbf in)
Strip length	7 mm (0.2756 in)

TEMPERATURE MEASUREMENT INPUT (3-wire measurement)

Update time	approx. 200 ms
Connectible sensors	PT100, PT1000, KTY83, KTY84
Total load (sensor and cable)	max. 4 k Ω
Line length	up to 30 m not shielded; greater than 30 m shielded

SENSOR TYPE	TEMPERATURE RANGE	RESISTANCE RANGE	MEASUREMENT UNCERTAINTY
KTY83	-55 °C ... +175 °C (-67 °F..to +347 °F)	500 Ω ... 2.6 k Ω	\pm 1.5% rng ¹⁾
KTY84	-40 °C ... +300 °C (-40 °F..to +572 °F)	350 Ω ... 2.6 k Ω	\pm 1.5% rng ¹⁾
PT100	-99 °C ... +500 °C (-146.2 °F..to +932 °F)	60 Ω ... 180 Ω	\pm 1.5% rng ¹⁾
PT1000	-99 °C ... +500 °C (-146.2 °F..to +932 °F)	600 Ω ... 1.8 k Ω	\pm 1.5% rng ¹⁾

¹⁾ rng = measuring range

CONNECTION CAPACITY OF THE TERMINALS (TEMPERATURE MEASUREMENT INPUT)

Single core, multi-core, fine-stranded	0.2 – 1.5 mm ² , AWG 24-16
Wire ferrules (non-insulated)	0.2 – 1.5 mm ²
Wire ferrules (insulated)	0.2 – 1.5 mm ²
Tightening torque	0.25 Nm (1.77 – 2.21 lbf in)
Strip length	7 mm (0.2756 in)

VOLTAGE MEASUREMENT INPUTS

Three-phase 4-wire systems (L-N/L-L)	max. 277 V / 480 V
Three-phase 3-wire systems (L-L)	max. 480 V
Resolution	0.01 V
Measuring range L-N	0 ¹⁾ ... 600 Vrms
Measuring range L-L	0 ¹⁾ ... 1000 Vrms
Crest factor	2 (relative to 480 Vrms)
Overvoltage category	300 V CAT III
Rated surge voltage	4 kV
Protection of the voltage measurement	1 – 10 A
Impedance	4 MΩ/phase
Power consumption	approx. 0.1 VA
Sampling frequency	20 kHz/phase
Transients	> 50 μs
Frequency of the fundamental oscillation	45 Hz ... 65 Hz
Resolution	0.001 Hz

¹⁾ The UMG device can only determine measured values if a voltage L-N of greater than 10 Vrms or a voltage L-L of greater than 18 Vrms is present at at least one voltage measurement input.

CURRENT MEASUREMENT INPUT

Nominal current	5 A
Rated current	6 A
Fuse protection for direct measurement (without current transformer)	6 A, Char. B (approved according to UL/IEC)
Display resolution	10 mA
Measuring range	0.005 .. 7 Arms
Crest factor	2 (relative to 6 Arms)
Overvoltage category	300 V CAT III
Rated surge voltage	4 kV
Power consumption	approx. 0.2 VA (Ri = 5 mΩ)
Overload for 1 s	100 A (sinusoidal)
Sampling frequency	20 kHz
Phase angle measuring accuracy	0.15°

CONNECTION CAPACITY OF THE TERMINALS (VOLTAGE AND CURRENT MEASUREMENT)

Connectible conductors. Only one conductor may be connected per terminal!

Single core, multi-core, fine-stranded	0.08 – 4.0 mm ² , AWG 28-12
Wire ferrules (non-insulated)	0.25 – 2.5 mm ²
Wire ferrules (insulated)	0.25 – 2.5 mm ²
Strip length	8–9 mm (0.31 – 0.35 in)

RS-232 INTERFACE

Connection	5-pole screw terminals
Protocol	Modbus RTU/Slave

RS-485 INTERFACE

Connection	2-pole screw terminals
Protocol	Modbus RTU/Slave, Modbus RTU/Master
Transmission rate	9.6 kbps, 19.2 kbps, 38.4 kbps, 57.6 kbps, 115.2 kbps, 921.6 kbps

TERMINAL CONNECTION CAPACITY (SERIAL INTERFACE–RS-485)

Connectible conductors. Only one conductor may be connected per terminal!

Single core, multi-core, fine-stranded	0.2 – 1.5 mm ² , AWG 28-16
Wire ferrules (non-insulated)	0.2 – 1.5 mm ² , AWG 26-16
Wire ferrules (insulated)	0.2 – 1.5 mm ² , AWG 26-16
Tightening torque	0.2 – 0.25 Nm (1.77 – 2.21 lbf in)
Strip length	7 mm (0.2756 in)

PROFIBUS INTERFACE (OPTION)

Connection	SUB D 9-pin
Protocol	Profibus DP/V0 according to EN 50170
Transmission rate	9.6 kBaud to 12 MBaud

ETHERNET INTERFACE

Connection	RJ45
Function	Modbus gateway, embedded web server (HTTP)
Protocols	TCP/IP, EMAIL (SMTP), DHCP client (BootP), Modbus/TCP (Port 502), ICMP (Ping), NTP, TFTP, Modbus RTU over Ethernet (Port 8000), FTP SNMP

POTENTIAL ISOLATION AND ELECTRICAL SAFETY OF THE INTERFACES

- The RS-485, RS-232, Profibus and Ethernet interfaces are double insulated from the current and voltage measurement inputs as well as from the supply voltage.
- The RS-232 and RS-485 interfaces are not isolated from each other and from the temperature measurement input.
- The Profibus and Ethernet interfaces are functionally isolated from each other and from the RS-232, RS-485, temperature measurement input and digital inputs and outputs.
- The interfaces of the devices connected here must have double or reinforced insulation from mains voltages (according to IEC 61010-1: 2010).

MEASUREMENT UNCERTAINTY

The measurement uncertainty of the device applies to its use for the following measuring ranges. The measured value must be within the specified limits. The measurement uncertainty is not specified outside these limits.

Measured value	Measurement uncertainties
Voltage	± 0.2% according to DIN EN 61557-12:2008
Current L	± 0.25% following DIN EN 61557-12:2008
Current N	± 1% according to DIN EN 61557-12:2008
Power	± 0.4% according to DIN EN 61557-12:2008
Harmonics U, I	Class 1, DIN EN 61000-4-7
Active energy	
Current transformer .. /5 A	Class 0.5 (IEC61557-12) Class 0.5S (IEC62053-22) Class 0.5 (ANSI C12.20)
Current transformer .. /1 A	Class 1 (IEC61557-12)
Reactive energy	
Current transformer .. /5 A	Class 2 (IEC62053-23)
Current transformer .. /1 A	Class 2 (IEC62053-23)
Frequency	±0.01 Hz
Internal clock	±1 minute/month (18 °C ... 28 °C) (64.4 °F to 82.4 °F)

The specification is valid under the following conditions:

- annual recalibration,
- a preheating time of 10 minutes,
- an ambient temperature of 18 ... 28 °C (64.4 °F to 82.4 °F).

If the device is operated outside the range of 18 ... 28 °C (64.4 °F ..to 82.4 °F), an additional measuring error of ±0.01% of the measured value per °C deviation must be taken into account.

POWER QUALITY ANALYZER

(CLASS S ACCORDING TO IEC 61000-4-30)



POWER QUALITY

- Analysis onboard
- 63rd harmonic
- Flicker measurement
- Events and transients
- Unbalance
- Half-wave RMS value recording

PROGRAMMABLE

- PLC functionality
- Jasic®
- APPs from the Janitza library

DEVICE HOMEPAGE

- Online & historical data
- Graphs available directly on homepage

INTERFACES

- Ethernet
- RS-232
- RS-485

GATEWAY

- Integration in PLC systems and BMS
- Simultaneous query of the interfaces

PERIPHERALS

- Digital inputs and outputs e.g. pulse input
- State monitoring and limit value output
- Thermistor input

MEASURING ACCURACY

- Class 0.2S
- Sampling frequency 20 kHz

MEASUREMENT DATA MEMORY

- 128 MB / approx. 2.37 months (according to factory setting)
- Record range up to 2 years

UMG 605-PRO

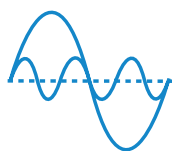

POWER QUALITY

Measurement of power quality parameters according to Class S



APPS

Watchdog monitoring of the PQ standards

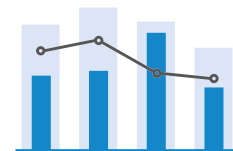

ENERGY MANAGEMENT

Additional acquisition of energy measurement data

UMG 605-PRO – DIMENSIONED DRAWING

All dimensions in mm

Front view

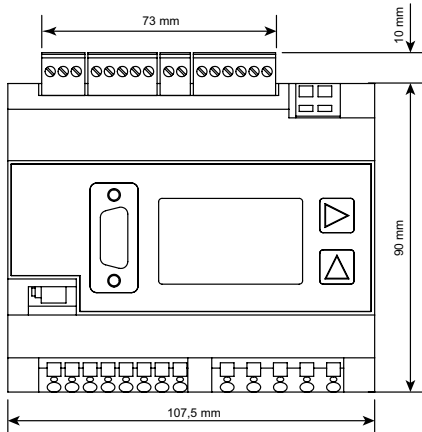

Side view

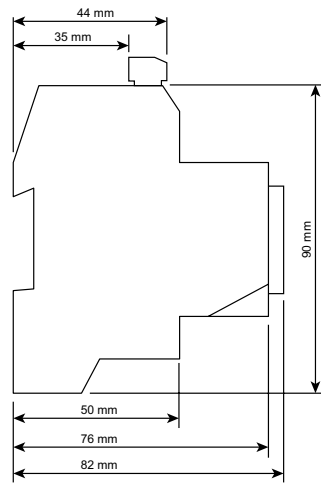

UMG 605-PRO – CONNECTION EXAMPLE

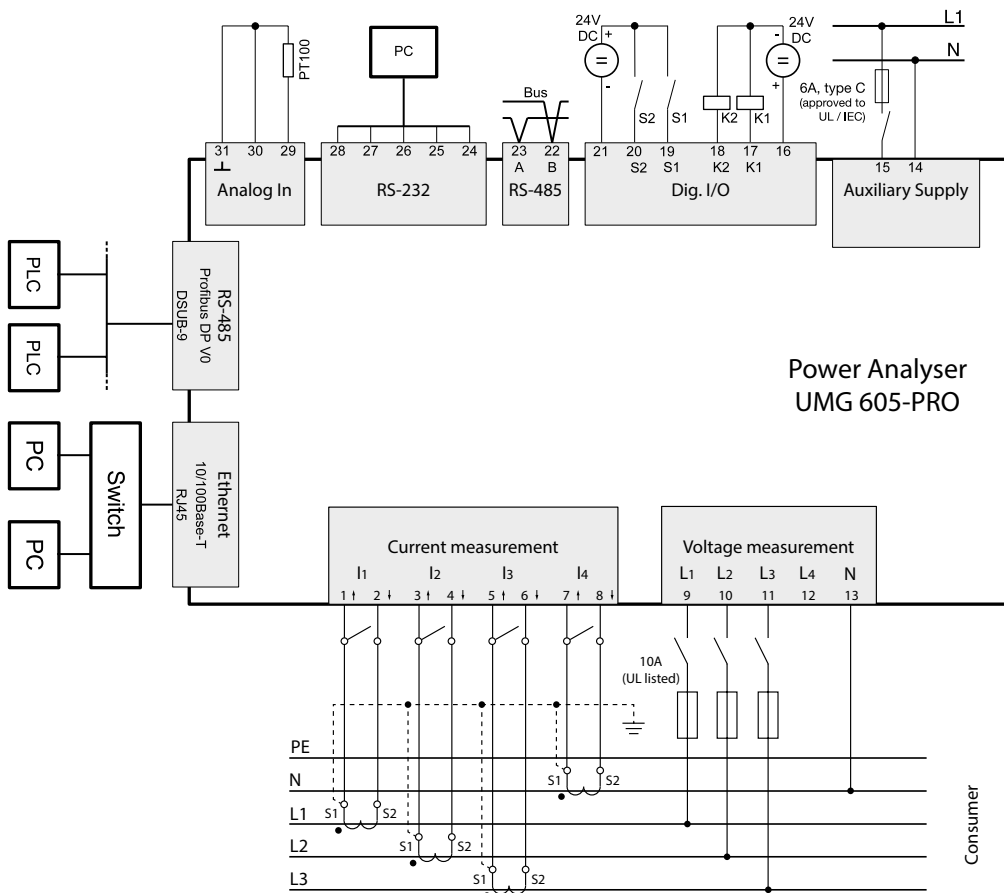

UMG 605-PRO – TECHNICAL DATA

UMG 605-PRO			
PART NUMBER	5216028		
PART NUMBER (UL)	5216227	–	5216229
Supply voltage, AC	95 ... 240 VAC	50 ... 110 V AC	20 ... 50 VAC
Supply voltage, DC	135 ... 340 V DC	50 ... 155 VDC	20 ... 70 V DC
DEVICE OPTIONS			
BACnet communication	5216083	5216083	5216083
GENERAL			
Net weight	350 g (0.77 lb)		
Device dimensions in mm (W x H x D)	approx. 90 x 82 x 107.5 mm (3.54 x 3.23 x 4.23 in) (according to DIN 43871:1992)		
Housing flammability classification	UL 94V-0		
Mounting orientation	As desired		
Installation/assembly	DIN rail 35 mm (according to IEC/EN60999-1, DIN EN 50022)		
Battery	Type, lithium CR2032, 3 V		
ENVIRONMENTAL CONDITIONS			
The device is for weather-protected and stationary use. ... fulfills operating conditions according to DIN IEC 60721-3-3.			
Working temperature range	–10 °C ... +55 °C (14 °F..to 131 °F)		
Relative humidity	5 to 95%, (at +25 °C/77 °F), no condensation		
Pollution degree	2		
Operating elevation	0 ... 2000 m above sea level		
Mounting orientation	As desired		
Ventilation	forced ventilation is not required.		
TRANSPORT AND STORAGE			
The following information applies to devices that are transported or stored in their original packaging.			
Free fall	1 m		
Temperature	–20 °C to +70 °C (–4 °F..to 158 °F)		
SUPPLY VOLTAGE			
The supply voltage must be connected to the device via a UL/IEC approved fuse (6A Char. B).			
Option 230 V:			
Nominal range	95 V ... 240 V (50/60 Hz) / DC 135 V ... 340 V		
Operating range	±10% of nominal range		
Power consumption	max. 3.2 W / 9 VA		
Overvoltage category	300 V CAT II		
Option 90 V (without UL approval):			
Nominal range	50 V ... 110 V (50/60 Hz) / DC 50 V ... 155 V		
Operating range	±10% of nominal range		
Power consumption	max. 3.2 W / 9 VA		
Overvoltage category	300 V CAT II		
Option 24 V:			
Nominal range	20 V ... 50 V (50/60 Hz) / DC 20 V ... 70 V		
Operating range	±10% of nominal range		
Power consumption	max. 5 W / 8 VA		
Overvoltage category	150 V CAT II		

CONNECTION CAPACITY OF THE TERMINALS (SUPPLY VOLTAGE)

Connectible conductors. Only one conductor may be connected per terminal!

Single core, multi-core, fine-stranded	0.08 – 2.5 mm ² , AWG 28-12
Terminal pins, wire ferrules	1.5 mm ² , AWG 16

PROTECTION CLASS

Protection class II according to IEC 60536 (VDE 0106, Part 1), no ground wire connection is required!

Protection against foreign matter and water	IP20 according to EN60529, September 2014, IEC60529:2013
---	--

DIGITAL INPUTS

S0 pulse input

Maximum counter frequency	20 Hz
---------------------------	-------

Switching input

Input signal applied	18 V ... 28 VDC (typically 4 mA)
Input signal not applied	0 ... 5 VDC, current less than 0.5 mA
Response time (Jasic program)	200 ms
Line length	up to 30 m not shielded; greater than 30 m shielded

DIGITAL OUTPUTS (2 digital outputs; solid state relays, not short-circuit proof)

Switching voltage	max. 60 VDC, 30 VAC
Switching current	max. 50 mA _{eff} AC/DC
Response time (Jasic program)	200 ms
Output of voltage dips	20 ms
Output of voltage surges	20 ms
Switching frequency	max. 20 Hz
Line length	up to 30 m not shielded; greater than 30 m shielded

TERMINAL CONNECTION CAPACITY: DIGITAL INPUTS AND OUTPUTS

Single core, multi-core, fine-stranded	0.2 – 1.5 mm ² , AWG 24-16
Cable end sleeve (not insulated)	0.2 – 1.5 mm ²
Cable end sleeve (insulated)	0.2 – 1.5 mm ²
Tightening torque	0.25 Nm (2.21 lbf in)
Stripping length	7 mm (0.2756 in)

TEMPERATURE MEASUREMENT INPUT

Update time	approx. 200 ms
Connectible sensors	PT100, PT1000, KTY83, KTY84
Total load (sensor and cable)	max. 4 k Ω
Line length	up to 30 m not shielded; greater than 30 m shielded

SENSOR TYPE	TEMPERATURE RANGE	RESISTANCE RANGE	MEASUREMENT UNCERTAINTY
KTY83	-55 °C ... +175 °C (-67 °F ..to 347 °F)	500 Ω ... 2.6 k Ω	\pm 1.5% rng ¹⁾
KTY84	-40 °C ... +300 °C (-40 °F ..to 572 °F)	350 Ω ... 2.6 k Ω	\pm 1.5% rng ¹⁾
PT100	-99 °C ... +500 °C (-146.2 °F ..to 932 °F)	60 Ω ... 180 Ω	\pm 1.5% rng ¹⁾
PT1000	-99 °C ... +500 °C (-146.2 °F ..to 932 °F)	600 Ω ... 1.8 k Ω	\pm 1.5% rng ¹⁾

1) rng = measuring range

TERMINAL CONNECTION CAPACITY: TEMPERATURE MEASUREMENT INPUT

Single core, multi-core, fine-stranded	0.2 – 1.5 mm ² , AWG 24-16
Cable end sleeve (not insulated)	0.2 – 1.5 mm ²
Cable end sleeve (insulated)	0.2 – 1.5 mm ²
Tightening torque	0.25 Nm (2.21 lbf in)
Stripping length	7 mm (0.2756 in)

RS-232 INTERFACE

Connection	5-pole screw terminals
Protocol	Modbus RTU/Slave
Transmission rate	9.6 kbps, 19.2 kbps, 38.4 kbps, 57.6 kbps, 115.2 kbps

RS-485 INTERFACE

Connection	2-pole screw terminals
Protocol	Modbus RTU/Slave, Modbus RTU/Master
Transmission rate	9.6 kbps, 19.2 kbps, 38.4 kbps, 57.6 kbps, 115.2 kbps, 921.6 kbps

PROFIBUS INTERFACE

Connection	SUB D 9-pin
Protocol	Profibus DP/V0 according to EN 50170
Transmission rate	9.6 kBaud to 12 MBaud

ETHERNET INTERFACE

Connection	RJ45
Function	Modbus gateway, embedded web server (HTTP)
Protocols	TCP/IP, EMAIL (SMTP), DHCP client (BootP), Modbus/TCP (Port 502), ICMP (Ping), NTP, TFTP, Modbus RTU over Ethernet (Port 8000), FTP SNMP.

VOLTAGE MEASUREMENT INPUTS

Three-phase 4-wire systems (L-N/L-L)	max. 277 V / 480 V
Three-phase 3-wire systems (L-L)	max. 480 V
Resolution	0.01 V
Crest factor	2 (relative to 480 Vrms)
Overvoltage category	300 V CAT III
Rated surge voltage	4 kV
Protection of the voltage measurement	1 – 10 A
Impedance	4 M Ω /phase
Power consumption	approx. 0.1 VA
Sampling frequency	20 kHz/phase
Transients	> 50 μ s
Frequency of the fundamental oscillation	15 Hz ... 440 Hz
Resolution	0.001 Hz

VOLTAGE MEASUREMENT INPUTS

Nominal current	5 A
Rated current	6 A
Fuse protection for direct measurement (without current transformer)	6 A, Char. B (approved according to UL/IEC)
Display resolution	10 mA
Crest factor	2 (relative to 6 Arms)
Overvoltage category	300 V CAT III
Rated surge voltage	4 kV
Power consumption	approx. 0.2 VA (R _i = 5 m Ω)
Overload for 1 s	100 A (sinusoidal)
Sampling frequency	20 kHz
Phase angle measuring accuracy	0.15 °

CONNECTION CAPACITY OF THE TERMINALS (CURRENT MEASUREMENT AND VOLTAGE MEASUREMENT)

Connectible conductors. Only one conductor may be connected per terminal!

Single core, multi-core, fine-stranded	0.08 – 4 mm ² , AWG 24-16
Cable end sleeve (not insulated)	0.25 – 2.5 mm ²
Cable end sleeve (insulated)	0.25 – 2.5 mm ²
Stripping length	8-9 mm (0.31 - 0.35 in)

MULTI-CHANNEL OPERATING CURRENT AND RESIDUAL CURRENT MONITORING DEVICE



INTERFACES

- RS-485

PERIPHERALS

- Pulse output
- Relay/ PLC input

POWER QUALITY

- Harmonics up to the 63rd harmonic
- Crest factor/harmonic distortion factor
- Minimum and maximum values for currents
- Limit value for each current channel

20 CURRENT MEASUREMENT CHANNELS

- True RMS measurement
- High sampling rate of 20 kHz
- Measurement of operating current or RCM

COMMUNICATION

- Modbus RTU

MEASURING ACCURACY

- Class 1
- Current: 1%
- Voltage: 1%
- Sampling rate 20 kHz

MEASUREMENT DATA MEMORY

- 768 kB / approx. 1 month (with factory setting)

MODULAR

- Expand to up to 96 measuring channels
- Integrated current transformers
- Display of the status by means of LEDs

UMG 20CM

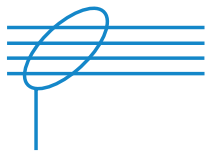

RCM

Maximum safety for systems and personnel, improved fire protection

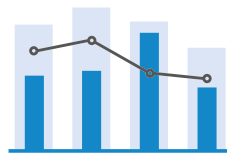

ENERGY MANAGEMENT

Optional use of the current channels for operating current measurement

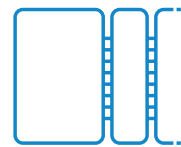

MODULAR

Modular expansion through active transformer bar

UMG 20CM – DIMENSIONED DRAWING

All dimensions in mm

Front view

Side view

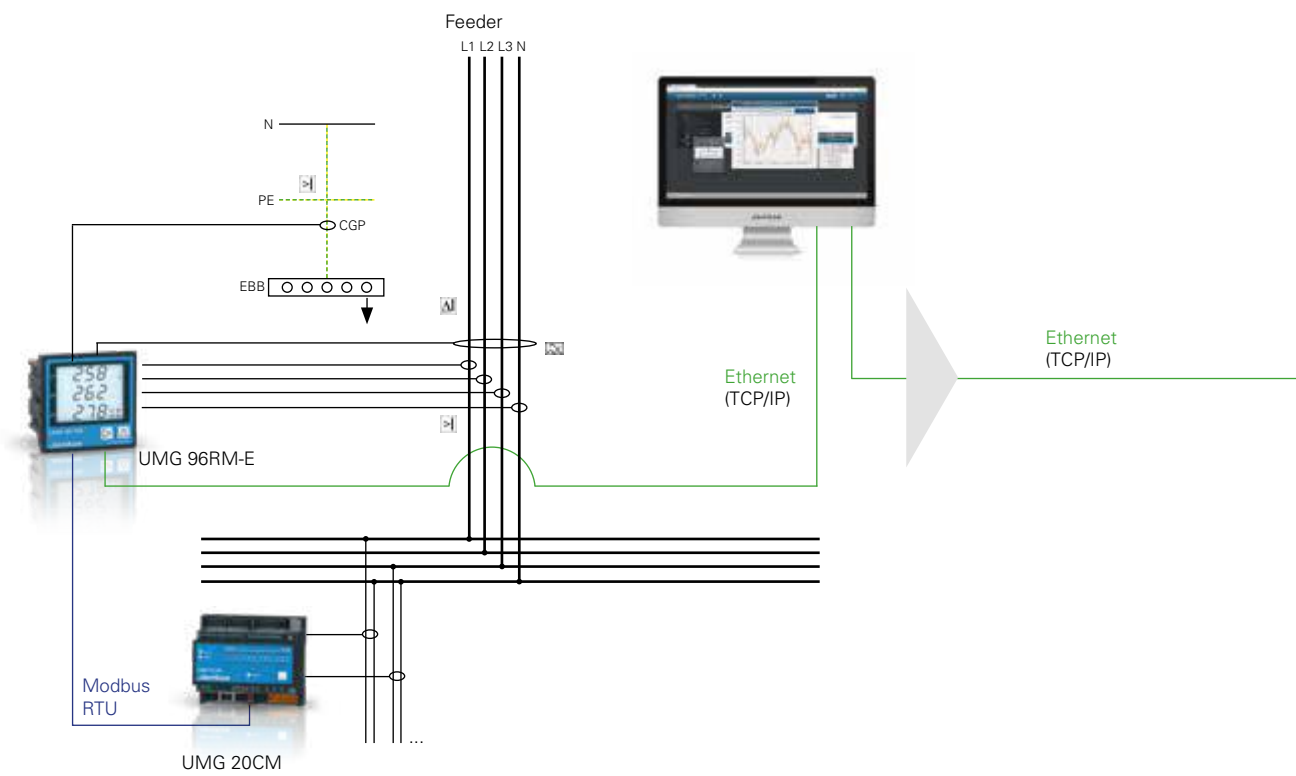
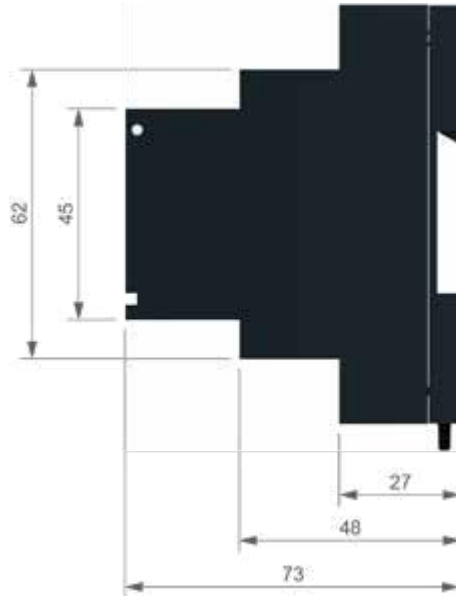
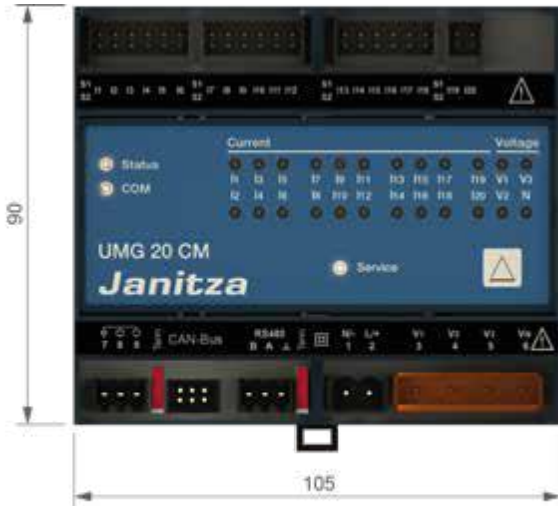
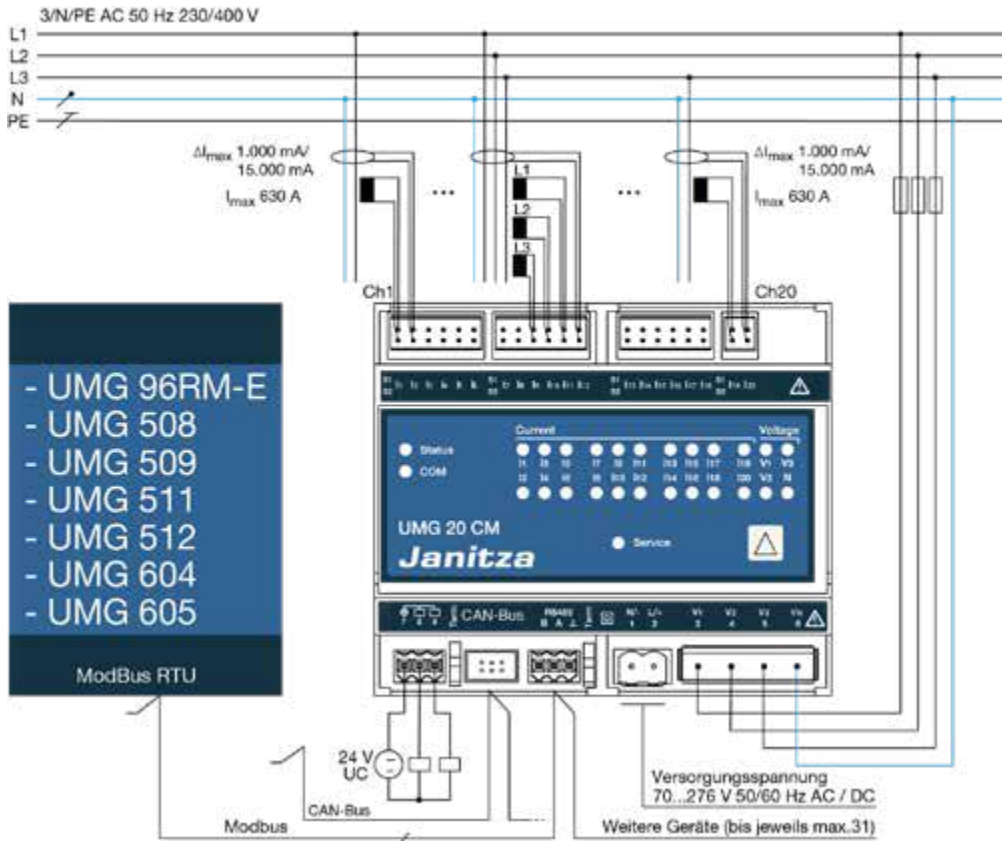
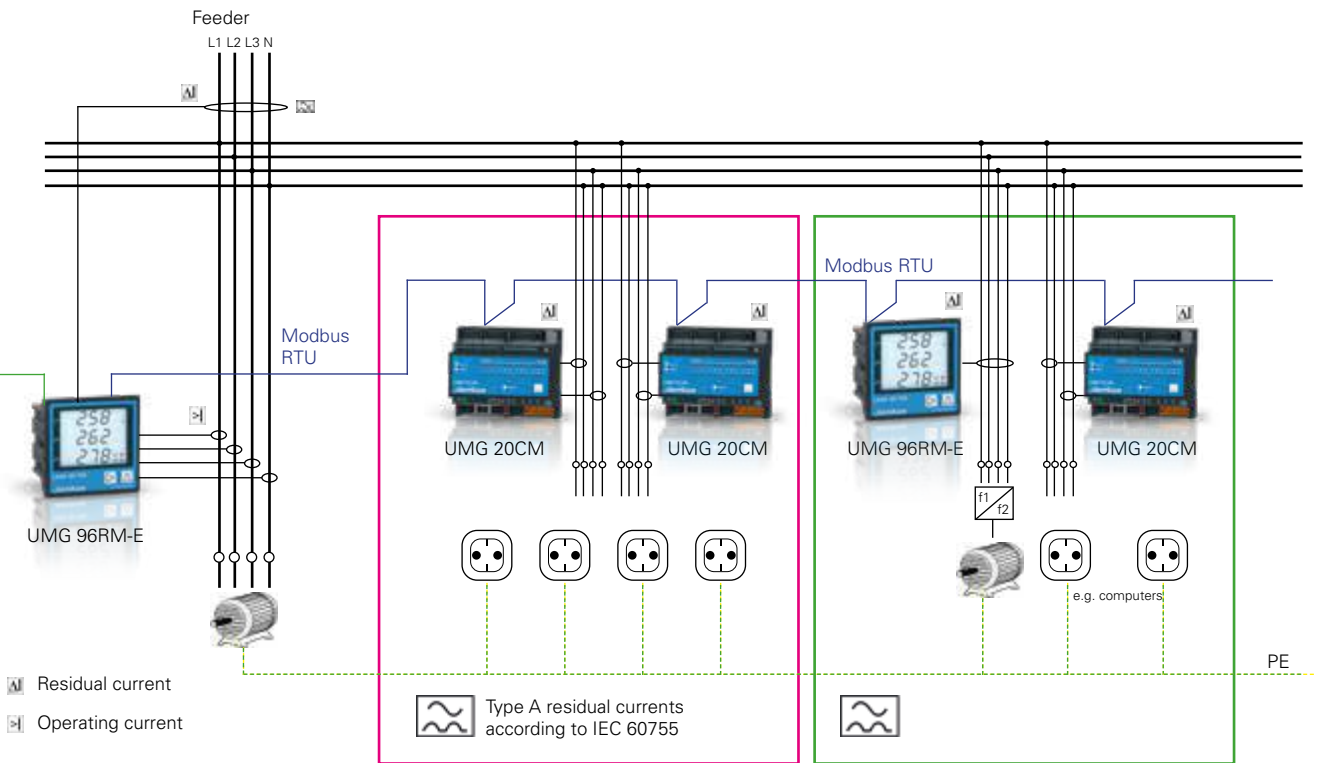

Fig.: The 20 channels of the UMG 20CM can be optionally used for residual or operating current monitoring using the corresponding current transformers. Residual current monitoring detects the residual currents flowing to ground or via other paths.

UMG 20CM – CONNECTION EXAMPLE



Recommendation: When using several UMG 20CM measuring channels, the bus should not contain more than 10 devices of type UMG 20CM. When using the APP "20CM Webmonitor", the number is limited to 5 devices due to the APP management.



UMG 20CM – APPLICATION EXAMPLE

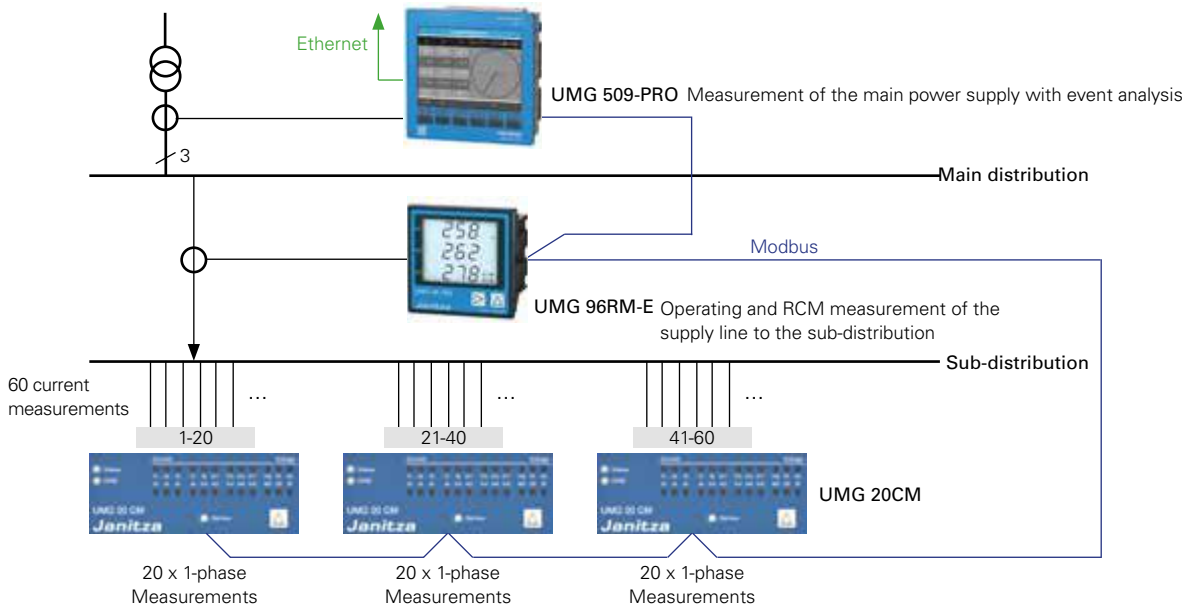

Fig.: Extremely compact solution for complete monitoring over three levels with state-of-the-art master-slave communication architecture

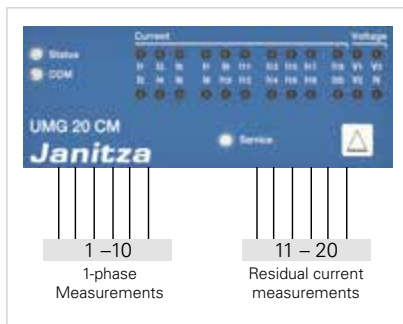

Fig.: 10 single-phase operating current measurements, 10 single-phase residual current measurements

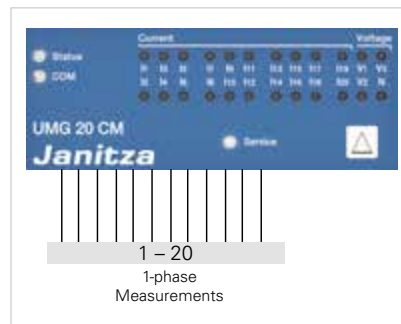

Fig.: 20 single-phase operating current or RCM measurements

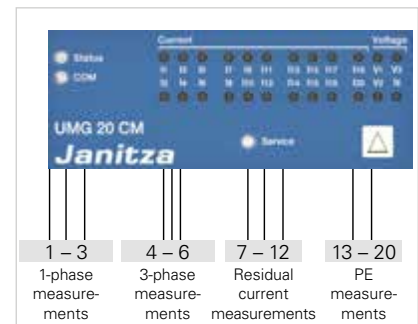

Fig.: 3 single-phase operating current measurements, 1 three-phase operating current measurement, 6 single-phase residual current measurements, 8 single-phase PE measurements

UMG 20CM – TECHNICAL DATA

UMG 20CM	
PART NUMBER	1401625
GENERAL	
Supply voltage	90 ... 276 VAC / 90 ... 276 VDC
Type of measurement	Continuous true RMS measurement up to the 63rd harmonic
Operating voltage	90 ... 276 VAC and DC
Measurement in quadrants	4
Networks TN, TT, IT	TN, TT, IT
Measurement in single-phase/multiphase networks	1 ph, 2 ph, 3 ph and up to 20 times 1 ph
MEASURED VOLTAGE INPUT	
Overvoltage category	300 V CAT III
Measuring range, voltage L-N, AC (without transformer)	10 ... 300 Vrms
Measuring range, voltage L-L, AC (without transformer)	10 ... 480 Vrms
Resolution	0.1 V
Impedance	1.3 M Ω / phase
Frequency measuring range	45 ... 65 Hz
Sampling frequency	20 kHz / phase
MEASURED CURRENT INPUT	
Operating current evaluation range	0 ... 630 A
Residual current evaluation range	10 mA ... 1 A/50 mA ... 15 A *
Resolution	1 mA
Cut-off frequency	3.2 kHz
Relative deviation	\pm 1%
<small>* with additional resistor (load) of 3.9 Ω (part no.: 1503086)</small>	
MONITORING FUNCTION	
Response function	0 ... 650 s
Reset delay time	0 ... 650 s
Delay resolution	10 ms
DIGITAL INPUTS AND OUTPUTS	
Number of digital outputs	2
Switching voltage	max. 60 VDC, 30 VAC
Maximum current	350 mA
Switch-on resistance	2 Ω
Maximum cable length	up to 30 m not shielded, from 30 m shielded
POWER CONSUMPTION	
Power consumption (own consumption)	3 W (7 AV)
Voltage inputs 1 ph/3 ph	40 mW/120 mW
Current inputs (single)	max. 10 mW (at 0.8 Ω load)
MECHANICAL PROPERTIES	
Weight	270 g (0.6 lb)
Device dimensions in mm (W x H x D)	105 x 90 x approx. 73 (4.13 x 3.54 x 2.87 in)
Protection class according to EN 60529	IP20
Mounting according to IEC EN 60999-1 / DIN EN 50022	35 mm DIN profile rail

CONNECTION CAPACITY OF THE TERMINALS (voltage and current measurement)

Connectable conductors; Only one conductor may be connected per terminal!

Single core, multi-core, fine-stranded	0.2 ... 1 mm ² , AWG 26-12 (current) 0.08 ... 4.0 mm ² , AWG 28-12 (voltage)
Terminal pins, wire ferrules	0.2...2.5 mm ²
Tightening torque	0.4...0.5 Nm
Strip length	7 mm

ENVIRONMENTAL CONDITIONS

Temperature range	Operation: K55 (-10 °C ... +55 °C) (14 °F..to 131 °F)
Relative humidity	Operation: 5 ... 95% (at 25 °C/77 °F)
Operating elevation	0 ... 2000 m above sea level
Pollution degree	2
Mounting orientation	As desired

ELECTROMAGNETIC COMPATIBILITY

Electromagnetic compatibility of equipment	Directive 2004/108/EC
Electrical equipment for use within specified voltage limits	Directive 2006/95/EC

DEVICE SAFETY

Safety regulations for electrical measuring, control, and laboratory devices	
Part 1: General requirements	IEC/EN 61010-1
Part 2-030: Special requirements for test and measurement circuits	IEC/EN 61010-2-030

IMMUNITY FROM INTERFERENCE

Class A: Industrial area	IEC/EN 61326-1
Electrostatic discharge	IEC/EN 61000-4-2
Voltage dips	IEC/EN 61000-4-11

EMITTED INTERFERENCE

Class B: Residential area	IEC/EN 61326-1
RFI field strength 30 ... 1000 MHz	IEC/CISPR11/EN 55011
RFI voltage 0.15 ... 30 MHz	IEC/CISPR11/EN 55011

SAFETY

Europe	CE conformity marking
--------	-----------------------

MODULAR EXPANSION FOR THE UMG 20CM METER

Module 20CM-CT6 at a glance

- The 20CM-CT6 module is used to expand the UMG 20CM basic device
- A maximum of 16 modules with 6 channels each (up to 96 channels in total) can be added
- The measurement data of all modules are mapped via the UMG 20CM
- Internal communication and supply via CAN bus interface
- Measured value acquisition via integrated current transformers
- Memory for historical data
- RCM diagnostic variables onboard
- Display of the limit value monitoring status by means of 6 LEDs



MODULE 20CM-CT6 – DIMENSIONED DRAWING

All dimensions in mm

Front view



Bottom view

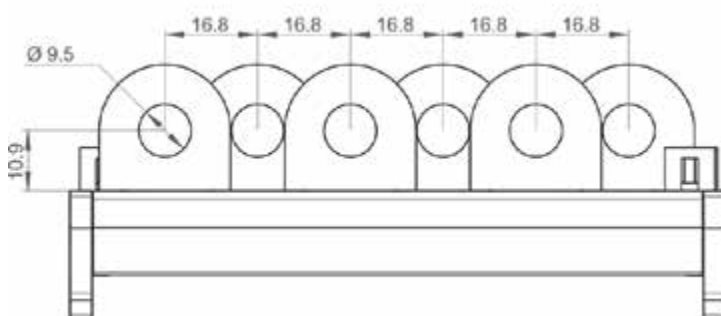

Side view

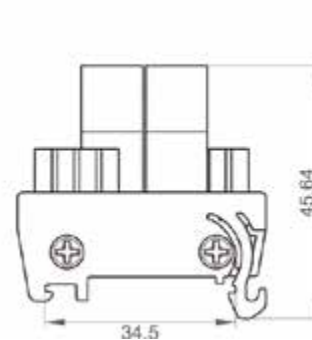

MODULE 20CM-CT6 – CONNECTION EXAMPLE

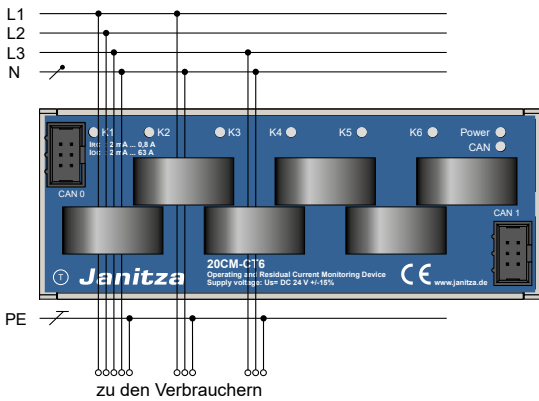

Fig.: Residual current detection

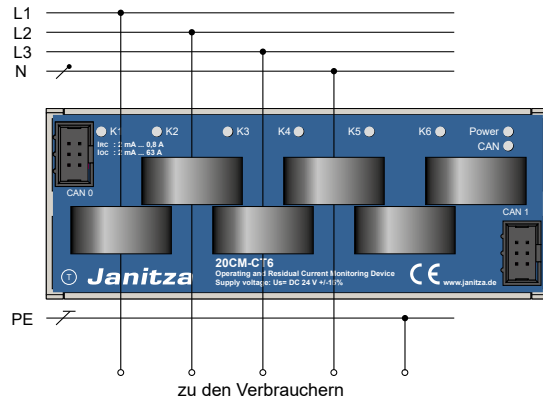

Fig.: Operating current measurement, e.g. 6 x 1-phase

MODULE 20CM-CT6 – TECHNICAL DATA

MODULE 20CM-CT6	
PART NUMBER	1401626
GENERAL	
Device dimensions in mm (W x H x D)	119 x 47 x 45 (4.69 x 1.85 x 1.77 in)
Net weight	170 g (0.37 lb)
Operating mode	Continuous operation
Protection class according to DIN EN 60529	IP20
Protection class	III
Flammability classification	UL-V0
The device meets the requirements of the standards	EN 62020:1998+A1:2005, (VDE 0663):2005
ENVIRONMENTAL CONDITIONS	
Ambient temperature (operational)	-10 °C ... +55 °C (14 °F..to 131 °F)
Storage temperature	-25 °C ... +70 °C (-13 °F..to 158 °F)
Altitude	0 ... 2000 m above sea level
Relative humidity (operating)	5 to 95% (at 25 °C/77 °F)
Pollution degree	3
Mounting orientation	Vertical/ horizontal
Mounting	35 mm DIN rail according to DIN EN 60175
SUPPLY VOLTAGE	
Supply voltage U_s (via internal bus)	DC 24 V ($\pm 10\%$, PELV)
Power consumption (own consumption)	2 W

MEASUREMENT

Type of measurement	Continuous true RMS measurement up to the 63rd harmonic
Measurement in quadrants	4
Systems	TN, TT, IT
Measurement in single-phase/multiphase networks	1 ph, 2 ph, 3 ph and up to 6 times 1 ph
Number of measuring channels	6
Number of measuring channels in the bus segment	max. 96
Measured value acquisition	Parallel, true RMS
Rated voltage (current transformer)	AC 250 V
Rated frequency (current transformer)	50 Hz
Response operating current	AC 2 mA ... 63 A
Response residual current	AC 2 mA ... 1 A
Resolution 2 mA ... 1 A	0.5 mA
1 A ... 63 A	35 mA
Cut-off frequency	3.3 kHz
Relative deviation (measuring range)	± 0.5%
Frequency range	45 ... 65 Hz

MONITORING FUNCTION

Response function	0 ... 650 s [10 ms]
Reset delay	0 ... 650 s [10 ms]
Delay resolution	10 ms

COMMUNICATION INTERFACE/PROTOCOL

Interface	2 x CAN/CAN 2.0 (according to ISO 11898)
Protocol	CANopen
Connection type CAN bus (CAN bus connector)	2 x 6-pin IDC connector
Connection cross section (solid/fine-stranded)	max. 9.3 mm (all cables and single wires)

DISPLAYS AND MESSAGES

Displays (operating and communication status) (Power of the measuring channels)	2 x multicolor LEDs 6 x multicolor LEDs
Messages	LED/CAN bus

ACCESSORIES*

LCAN-RS45 incl. 2 connection cables (2 m ribbon cable each, 1 x with 2 IDC connectors and 1 x with 3 IDC connectors)	Part no. 0802447
---	------------------

RESIDUAL CURRENT MONITORING DEVICE

(TYPE A, TYPE B, TYPE B+)



PERIPHERALS

- 2 digital alarm outputs
- 2 freely scalable analog outputs

COMMUNICATION

- Modbus RTU

RESIDUAL CURRENT MONITORING

- 2 channels
- Compatible with all Janitza residual current transformers
- All-current sensitive up to 20 kHz (Type A, B and B+)

RCM ANALYSIS VARIABLES

- Individual limit values can be set for type A, type B and type B+
- Individual frequencies for 1-2000 Hz
- Spectrum display for 2-20 kHz

MEASUREMENT METHOD/ TRANSFORMERS:

- Use of type A transformers for residual currents for a Type B/B+ measurement (measurement according to DIN EN 62020)
- Transformer: CT-AC RCM series, DACT 20, KBU 23/58/812 D

NETWORKS

- TN networks
- TT networks

DISPLAY

- LCD display
- Display of the momentary current values
- Errors and alarms

CONFIGURATION

- Completely configurable on site

RCM 202-AB



SAFETY

Alarms in case of limit violations
via outputs and Modbus



PRICE

Easy integration, use of
conventional transformers

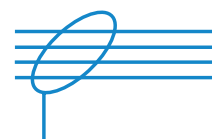

RCM

Type A, B & B+ (up to 20 kHz), also
with conventional type A transformers

RCM 202-AB – DIMENSIONED DRAWING

All dimensions in mm

Front view



Side view

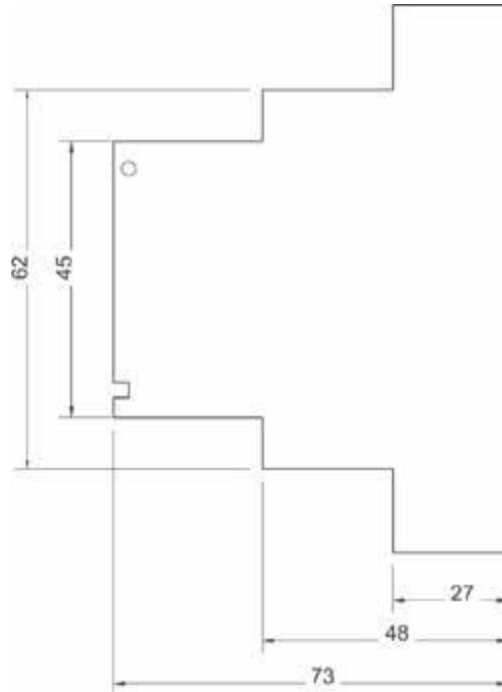

A	Sensitive to pulsed current Sinusoidal alternating current pulsed direct current	
B	Universally current sensitive All currents up to 2 kHz	
B +	Universally current sensitive All currents up to 20 kHz	<div style="border: 1px solid black; padding: 5px; display: inline-block; font-size: 2em; font-weight: bold;">kHz</div>

RCM 202-AB – APPLICATION EXAMPLE

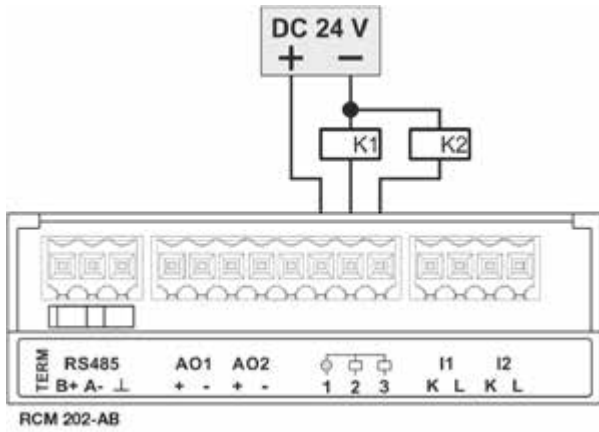

Fig.: Application example for RCM 202-AB in stand-alone operation – Connection of two relays to the digital outputs

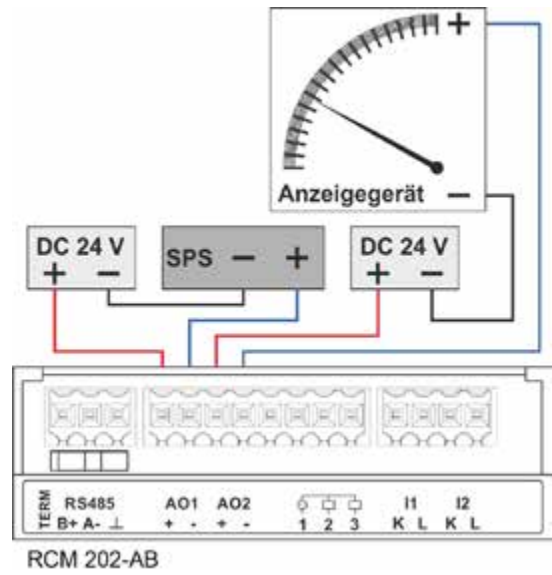

Fig.: Application example for analog outputs (interface 4 ... 20 mA) – Connection of a display device and a PLC to the analog outputs

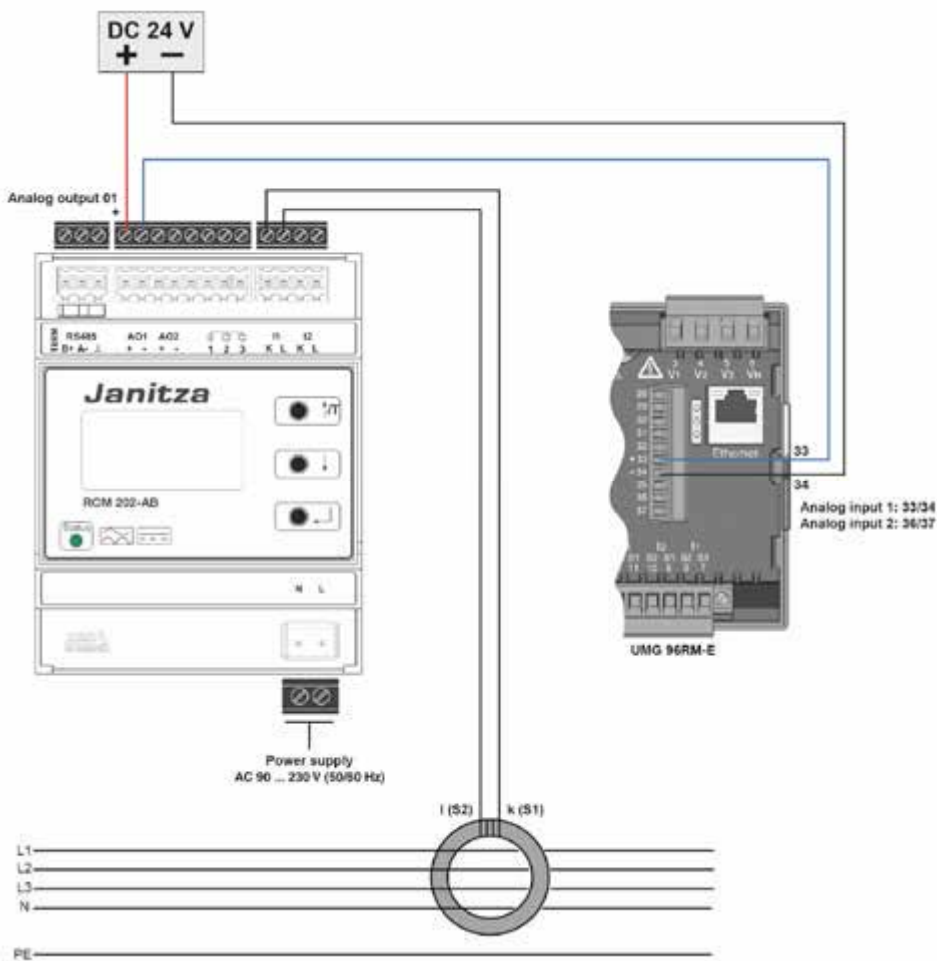

Fig.: Application example for analog outputs and UMG 96RM-E

RCM 202-AB – TECHNICAL DATA

RCM 202-AB	
PART NUMBER	1401627
GENERAL	
Supply voltage U_s	AC 90 ... 276 V/50 ... 60 Hz
Required external back-up fuse for the power supply	Circuit breaker 1-pole, 3 A, AC 230 V
Operating mode	Continuous operation
Power consumption (own consumption)	8 W
INSULATION COORDINATION ACCORDING TO IEC 60664-1	
Rated current I_b	4 kA
Rated surge voltage	4 kV
Pollution degree	2
Rated voltage	AC 250 V, 50 ... 60 Hz
TRANSFORMER	
Current transformer rated voltage	AC 20 ... 720 V
Current transformer rated frequency	0 ... 20 kHz
Current transformer rated current	(depending on type)
MEASURING CHANNELS	
Number of measuring channels	2 (current transformers, connectable)
Measured value acquisition	Parallel, true RMS
Evaluation	Residual current types A and B to IEC 62020
Rated residual current $I_{\Delta n}$	Configurable, 30 mA ... 20 A
Response delay for warning and alarm alerts, tv	Configurable, 10 ms ... 10 s
Reset delay	Configurable, 10 ms ... 10 s
TRANSFORMER CONNECTIONS	
Connection to current transformers	Line resistance max. 2 Ω
Transformer cable	2-conductor
LINE LENGTH	
Single wires (0.75 to 1.5 mm ²)	max. 1 m
Single wires twisted (0.75 to 1.5 mm ²)	max. 10 m
Shielded wiring (0.75 to 1.5 mm ²)	max. 10 m
DISPLAYS, ALERTS AND MEMORY	
Full graphic display (LCD)	128 x 64 pixels
LED status	Three-color
Controls	3 buttons
Menu languages	German, English, Spanish
Date and time	With RTC, zero-voltage safe
Configuration	on the RCM 202-AB in the configuration menu
Messages	Display/ LED/ Modbus/ digital outputs
Measured value memory	18,725 data records (ring buffer) with date and time
EXAMPLES	
Shielded cable 0.75 mm ² (shield to I)	Length max. 20 m (21.87 yd)
Cable type J-Y(ST)Y \varnothing 0.6 mm	Length max. 15 m (16.4 yd)
ANALOG OUTPUTS	
Interface	4 ... 20 mA
Quantity	2
Supply voltage of the analog outputs	DC 12 ... 24 V

DIGITAL OUTPUTS

Number of digital outputs	2
Switching voltage	max. DC 60 V, AC 30 V
Maximum current	350 mA
Switch-on resistance	2 Ω
Maximum cable length	up to 30 m (32.8 yd) unshielded, Greater than 30 m (32.8 yd) shielded

RS-485 INTERFACE

Protocol	Modbus RTU (RCM 202-AB as slave)
Interface	RS-485
Baud rate	Configurable, 9.6 ... 115.2 kbaud
Address range	1 ... 247
Max. line length (38.4 kbaud)	1200 m (1212.3 yd)
Cable (shielded, shield to PE at one end)	Unitronic Li2YCY(TP) 2x2x0.22 (Lapp cable)
Termination resistor	120 Ω (can be switched on at the device)

DEVICE SAFETY (Safety regulations for electrical measuring, control and laboratory devices)

Part 1: General requirements	IEC/EN 61010-1
Part 2-030: Special requirements for test and measurement circuits	IEC/EN 61010-2-030

IMMUNITY FROM INTERFERENCE

Class A: Industrial area	IEC/EN 61326-1
Electrostatic discharge	IEC/EN 61000-4-2
Voltage dips	IEC/EN 61000-4-11

EMITTED INTERFERENCE

Class B: Residential area	IEC/EN 61326-1
RFI field strength 30 ... 1000 MHz	IEC/CISPR11/EN 55011
RFI voltage 0.15 ... 30 MHz	IEC/CISPR11/EN 55011

STANDARDS

The RCM 202-AB fulfills the requirements according to EN 62020:1998+A1:2005 (VDE 0663):2005

ENVIRONMENTAL CONDITIONS

Ambient temperature during operation	-5 ... +55 °C (23 °F .. 131 °F)
Ambient temperature during storage	-25 ... +70 °C (-13 °F .. 158 °F)
Ambient temperature during transport	-25 ... +70 °C (-13 °F .. 158 °F)
Altitude	0 ... 2000 m (0 ... 1.24 mi)
Climate class according to IEC 60721-3-3 (operation)	3K5

INSTALLATION CONDITIONS

Mounting orientation	horizontal/vertical
Mounting	Rail mounting to DIN EN 60715
Device dimensions in mm (H x W x D)	71 x 90 x 73
Protection level to EN 60259	IP 20
Protection class	III
Flammability class Weight	UL 94V-0
Weight	approx. 170 g (0.375 lbs)
Connection type/line	Terminal blocks/copper
Connection cross section, solid/fine-stranded	0.2 ... 4 mm ² /0.2 ... 1.5 mm ² (AWG 24-15)

RESIDUAL CURRENT MONITORING DEVICE

(TYPE A FOR ROGOWSKI CURRENT
TRANSFORMERS)



RESIDUAL CURRENT MONITORING

- 1 connection
- Compatible with Janitza Rogowski coils
- Type A measurement up to 5 kHz
- DIN EN 62020

ROGOWSKI COIL

- Retrofittable
- Large cable cross sections and busbars
- Up to 4000 A

ALARM FUNCTION

- Configurable limit values
- Alarm output

PERIPHERALS

- 1 x 0-40 mA analog output

COMMUNICATION

- Modbus RTU

INTERFACE

- RS-485

OPERATION

- Current measurement range configurable directly on the device
- Button lock via Modbus

NETWORKS

- TN-S systems

CONFIGURATION

- Configurable on site

RCM 201-ROGO

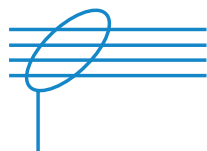

RCM

Acquisition of AC residual and residual currents in applications

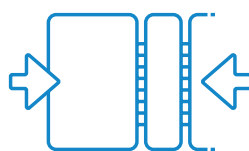

COMPACT

Compact design, flexible mounting of Rogowski coils



COMMUNICATION

Easy integration using Modbus communication

RCM 201-ROGO – CONNECTION EXAMPLE

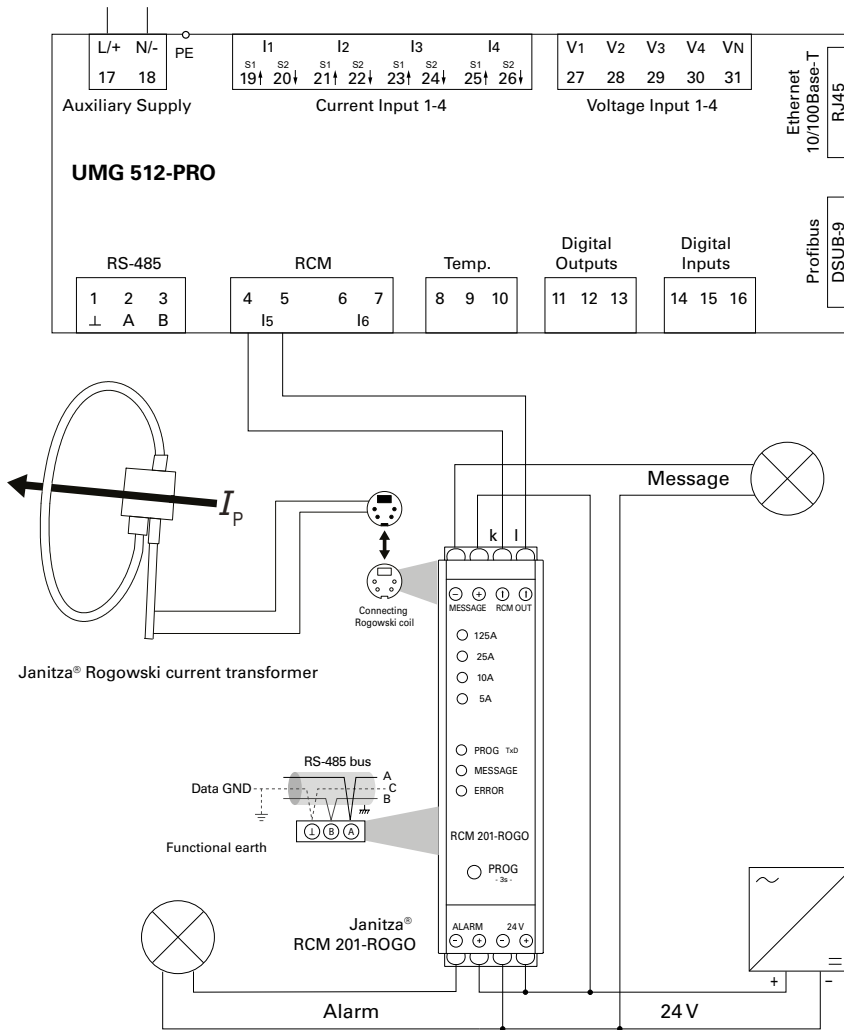

Fig.: Connection example to a UMG 512-PRO



ROGOWSKI COILS & RCM 201-ROGO – TECHNICAL DATA

ROGOWSKI COILS	
PART NUMBER (Ø 120 MM, COIL LENGTH 350 MM)	1503622
PART NUMBER (Ø 200 MM, COIL LENGTH 600 MM)	1503623
PART NUMBER (Ø 290 MM, COIL LENGTH 900 MM)	1503624
PART NUMBER (Ø 390 MM, COIL LENGTH 1200 MM)	1503625
PART NUMBER (Ø 580 MM, COIL LENGTH 1800 MM)	1503626

Connection cable length	3.0 m
Closure	Bayonet
Working temperature	-30 °C to +80 °C (-22 °F ... 176 °F)
Storage temperature	-40 °C to +80 °C (-40 °F ... 176 °F)
Secondary voltage	100 mV/1kA @ 50 Hz
Overvoltage category	1000 Vrms CAT III 600 Vrms CAT IV
Protection level	IP67

RCM 201-ROGO	
PART NUMBER	1503614

Dimensions	22.5 x 100 x 110 mm (W x H x D) 0.89 x 3.94 x 4.33 in (w x h x d)
Weight	approx. 0.2 kg (0.44 lb)
Power supply	24 VDC / 0.1 A
Connections	Screw terminal (max. 2.5 mm ²)
Rogowski loop connection	Mini-DIN 4-pin
Rated response residual current measuring ranges	2.5 A – 125 A 0.5 A – 25 A 0.2 A – 10 A 0.1 A – 5 A
Setting the current measurement ranges	Manually via button (> 3 s) or Modbus (measuring range selection via microcontroller and PGA)
Test alert and alarm output	Manually via button (> 6 s) or Modbus
Operating and measuring range display	Measuring range display: LED green Measuring range selection: LED yellow Alert output: LED yellow Alarm output: LED red
Nominal input voltage	100 µV / A
Output current	0 – 40 mA ~
max. output current at load = 0 Ω	70 mA ~
Overload current (continuous)	50 kA
Overload current (max. 1s)	100 kA
Transmission error	40 Hz ... 60 Hz < 1% 60 Hz ... 5 kHz < 5%
Rated frequency	40 Hz – 5 kHz
Load (40 mA output)	0 – 10 Ω
Operation lock	via MODBUS
Alarm output potential-free (opto) (programming via MODBUS)	Transistor output 24 _{VDC} / 100 mA
Output	Alarm normal (NO) Alarm inverted (NC)
Alarm functions	Residual current level Measuring loop interruption Overtemperature Undervoltage (24 V) Internal error
Response residual current, alarm output	10% – 100% (0.5% steps)
Hysteresis, response residual current level	5% (0 – 30%)
Alarm output response time	10 s (1 – 255 s)

MID ENERGY METER AND MEASUREMENT SYSTEM



COMMUNICATION

- Modbus
- M-Bus
- S0 pulse outputs

CERTIFICATION

- MID certified

ENERGY MANAGEMENT

- Cost center analysis
- Measuring transducer for PLC control or building management systems (BMS)
- Billing purposes
- Alarm function

MEASURING ACCURACY

- Class 1 for active energy

MEASURED VALUES

- Active energy & reactive energy
- Active power & reactive power

TAMPER-PROOF

- Lead-sealed terminal cover

ALTERNATING CURRENT METER B21

- Single-phase (1 + N)
- Direct connection up to 65 A
- Width: 2 DIN modules

THREE-PHASE METER B23

- Three-phase (3 + N)
- Direct connection up to 65 A
- For 3- and 4-wire connection
- Width: 4 DIN modules

TRANSFORMER METER B24

- Three-phase (3 + N)
- CT transformer connection, 1(6) A
- Transformer ratio freely configurable up to 9999/1-6
- For 3- and 4-wire connection
- Width: 4 DIN modules

MID ENERGY METERS



CERTIFICATION

MID certified



COMMUNICATION

Optionally as M-Bus
or Modbus

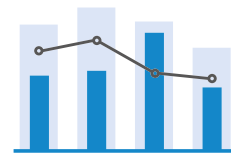

ENERGY MANAGEMENT

Legally valid billing &
acquisition for the BesAr

MID ENERGY METER B21 – ALTERNATING CURRENT METER, 65 A

- Alternating current meter, single-phase (1 + N)
- Direct connection up to 65 A
- With measured values and alarm function
- Width: 2 DIN modules
- Tested and approved according to MID*¹ and IEC
- Pulse output included



*1 In Switzerland, different regional requirements apply in connection with MID energy meters.

MID ENERGY METER B21 – TECHNICAL DATA

MID ENERGY METER B 21 – ALTERNATING CURRENT METER, 65 A

VOLTAGE V	ACCURACY CLASS	INPUTS/OUTPUTS	COMMUNICATION	TYPE	WEIGHT IN kg	PART NO.
1 x 230 V AC	Active energy: B (Class 1) Reactive energy: Class 2	2 outputs, 2 inputs	Pulse output	B21 311-10J	0.14	1401353
			Pulse output, RS-485	B21 312-10J	0.15	1401354
			Pulse output, M-Bus	B21 313-10J	0.15	1401355

MID ENERGY METER B21 – DIMENSIONED DRAWING

All dimensions in mm

Front view

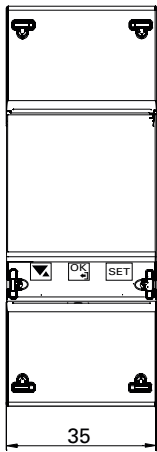

Side view

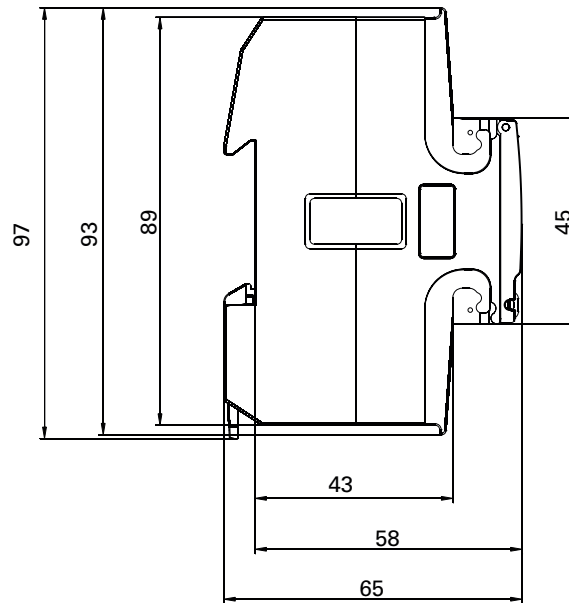

MID ENERGY METER B21 – CONNECTION EXAMPLE

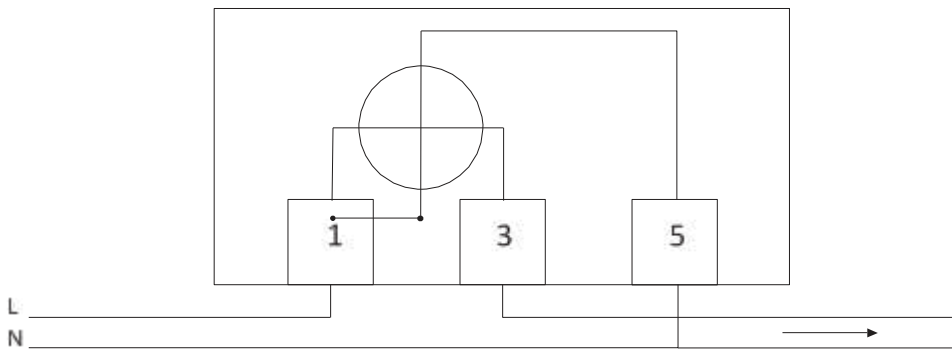
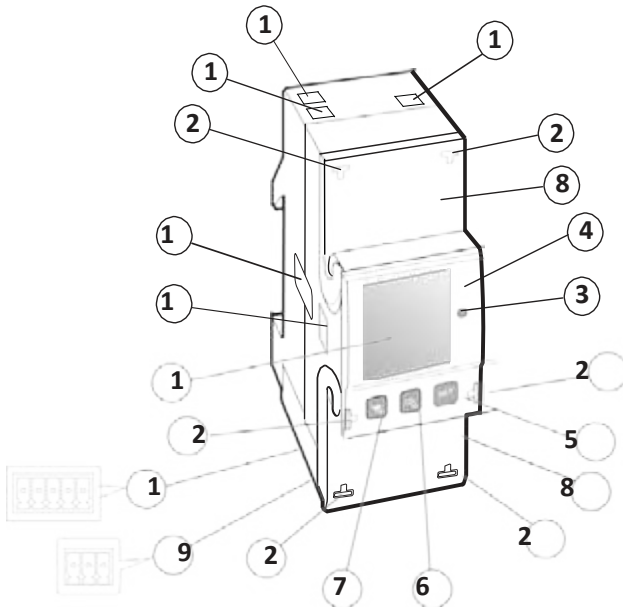

Fig.: 2-wire connection / 1 measuring unit

MID ENERGY METER B21 – DIMENSIONED DRAWING



NO.	DESCRIPTION	FUNCTION
1	Connecting terminals	Electrical connections
2	Lead-seal eyelets	To apply a lead seal to terminals
3	LED	Blinks proportionally to the measured energy
4	Product data/label	Contains information about the meter
5	SET button	To enter the configuration mode To confirm selections and menu items.
6	OK button	Short button stroke: Confirm selection Long button stroke: Return to previous menu or switch between standard and main menu To select a menu item
7	UP/DOWN button	Short button stroke: Down or forwards Long button stroke: Up or back
8	Lead-sealed cover	Protective cover with printed wiring diagram on the inside
9	Plug-in terminal for communication interfaces	Depending on meter type RS-485 (Modbus RTU) or M-Bus
10	Plug-in terminal for inputs and outputs	2 (relative to 480 Vrms)
11	LC display	To display the energy and measured values
12	Optical infrared interface (IR)	For internal use only!
13	Device seal	On both sides of the meter to protect against unauthorized opening of the meter

MID ENERGY METER B23 – THREE-PHASE METER, 65 A

- Three-phase meter, three-phase (3 + N)
- Direct connection up to 65 A
- With measured values and alarm function
- For 3- and 4-wire connection
- Width: 4 DIN modules
- Tested and approved according to MID*¹ and IEC
- Pulse output included



*1 In Switzerland, different regional requirements apply in connection with MID energy meters.

MID ENERGY METER B23 – TECHNICAL DATA

MID ENERGY METER B 23 – THREE-PHASE CURRENT METER, 65 A

VOLTAGE V	ACCURACY CLASS	INPUTS/OUTPUTS	COMMUNICATION	TYPE	WEIGHT IN kg	PART NO.
3 x 230/400 VAC	Active energy: B (Class 1) Reactive energy: Class 2	2 outputs, 2 inputs	Pulse output	B23 311-10J	0.33	1401356
			Pulse output, RS-485	B23 312-10J	0.34	1401357
			Pulse output, M-Bus	B23 313-10J	0.35	1401358

MID ENERGY METER B23 – DIMENSIONED DRAWING

All dimensions in mm

Front view

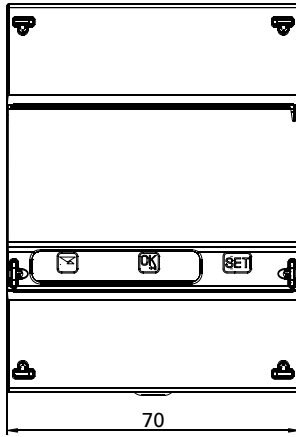

Side view

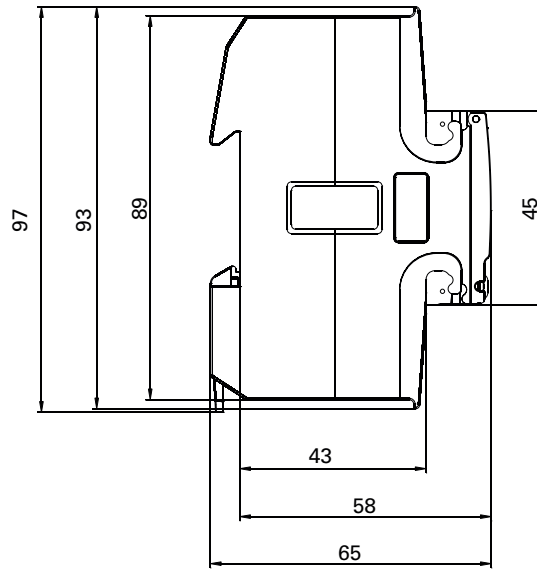

MID ENERGY METER B23 – CONNECTION EXAMPLE

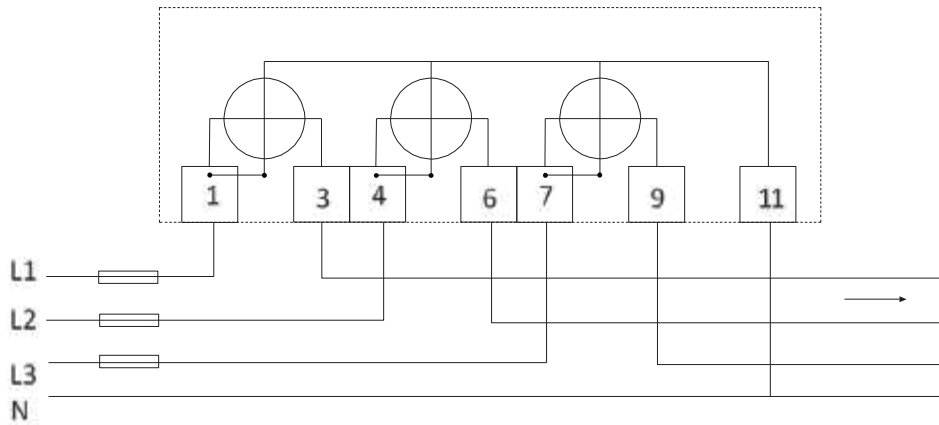

Fig.: 4-wire connection / 3 measuring units

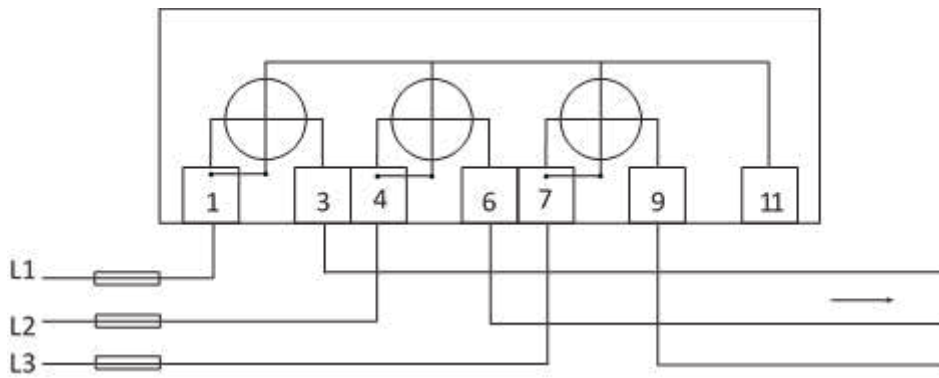

Fig.: 3-wire connection / 2 measuring units

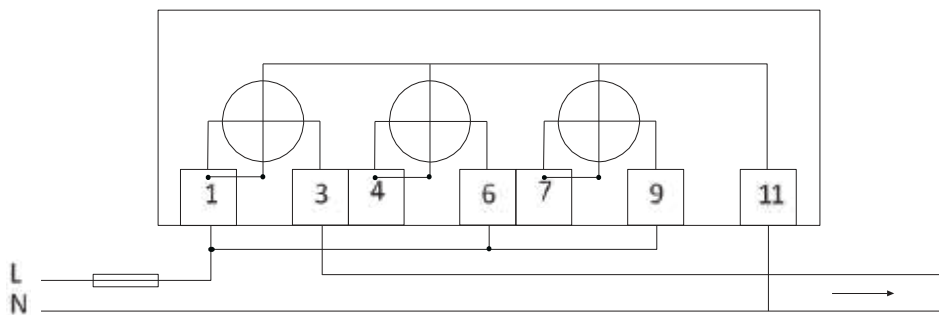
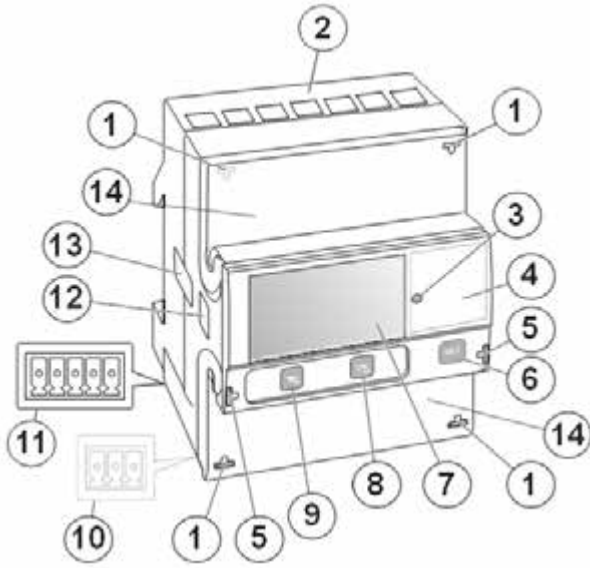

Fig.: 2-wire connection / 1 measuring unit

MID ENERGY METER B23 – DIMENSIONED DRAWING



NO.	DESCRIPTION	FUNCTION
1	Lead-seal eyelets	To apply a lead seal to terminals
2	Connecting terminals	Electrical connections
3	LED	Blinks proportionally to the measured energy
4	Product data/label	Contains information about the meter
5	Lead-seal eyelets	To seal the front cover
6	SET button	To enter the configuration mode
7	LC display	To display the energy and measured values
		To confirm selections and menu items.
8	OK button	Short button stroke: Confirm selection
		Long button stroke: Return to previous menu or switch between standard and main menu
		To select a menu item
9	UP/DOWN button	Short button stroke: Down or forwards
		Long button stroke: Up or back
10	Plug-in terminal for communication interfaces	Depending on meter type RS-485 (Modbus RTU) or M-Bus
11	Plug-in terminal for inputs and outputs	
12	Optical infrared interface (IR)	For internal use only!
13	Device seal	On both sides of the meter to protect against unauthorized opening of the meter
14	Lead-sealed cover	Protective cover with printed wiring diagram on the inside

MID ENERGY METER B24 – TRANSFORMER METER, 6 A

- Transformer meter, three-phase (3 + N)
- CT transformer connection, 1(6) A
- Transformer ratio freely configurable up to 9999/1-6
- With measured values and alarm function
- For 3- and 4-wire connection
- Width: 4 DIN modules
- Tested and approved according to MID*1 and IEC
- Pulse output included

*1 In Switzerland, different regional requirements apply in connection with MID energy meters.



MID ENERGY METER B24 – TECHNICAL DATA

MID ENERGY METER B 23 – THREE-PHASE CURRENT METER, 65 A

VOLTAGE V	ACCURACY CLASS	INPUTS/OUTPUTS	COMMUNICATION	TYPE	WEIGHT IN kg	PART NO.
3 x 230/400 VAC	Active energy: B (Class 1) Reactive energy: Class 2	2 outputs, 2 inputs	Pulse output	B24 311-10J	0.27	1401359
			Pulse output, RS-485	B24 312-10J	0.27	1401360
			Pulse output, M-Bus	B24 313-10J	0.29	1401361

MID ENERGY METER B24 – DIMENSIONED DRAWING

All dimensions in mm

Front view

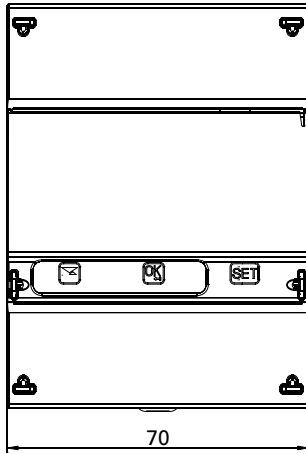

Side view

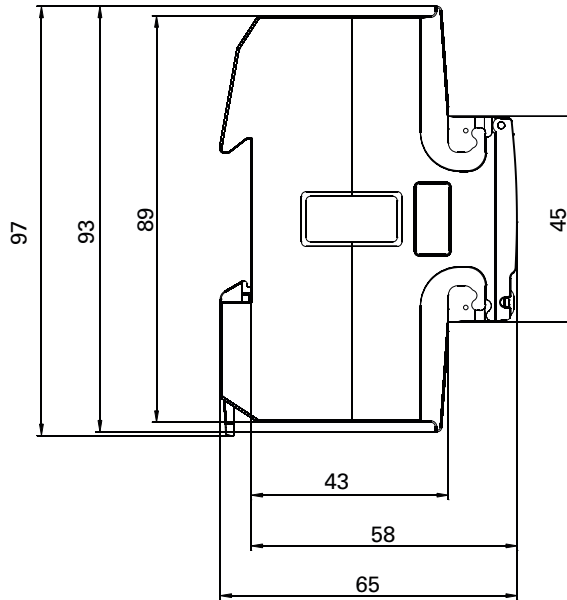

MID ENERGY METER B24 – CONNECTION EXAMPLE

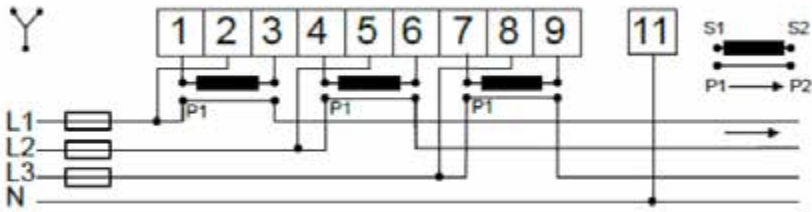

Fig.: 4-wire connection / 3 measuring units

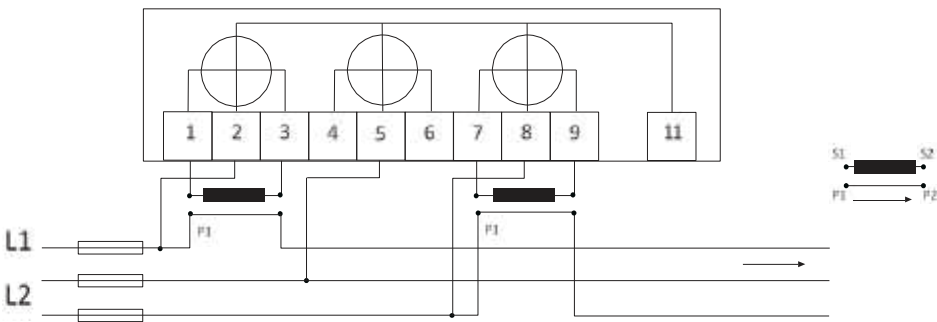

Fig.: 3-wire connection / 2 measuring units

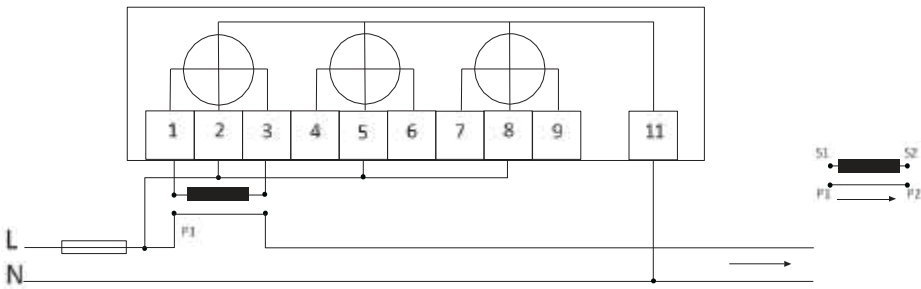
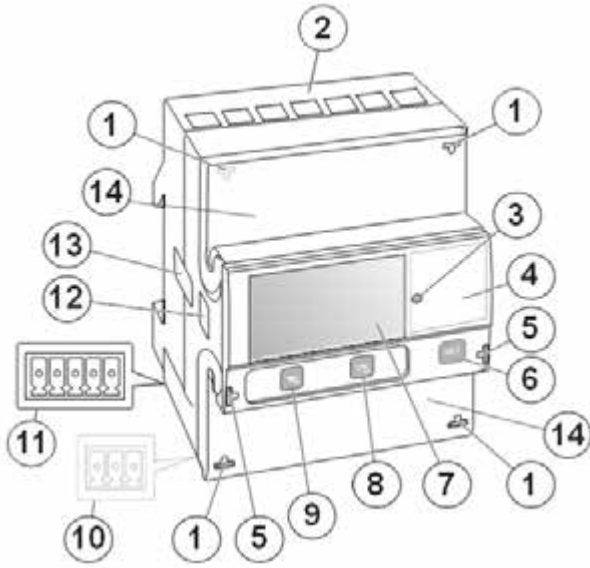

Fig.: 2-wire connection / 1 measuring unit

MID ENERGY METER B24 – DIMENSIONED DRAWING



NO.	DESCRIPTION	FUNCTION
1	Lead-seal eyelets	To apply a lead seal to terminals
2	Connecting terminals	Electrical connections
3	LED	Blinks proportionally to the measured energy
4	Product data/label	Contains information about the meter
5	Lead-seal eyelets	To seal the front cover
6	SET button	To enter the configuration mode
7	LC display	To display the energy and measured values
		To confirm selections and menu items.
8	OK button	Short button stroke: Confirm selection
		Long button stroke: Return to previous menu or switch between standard and main menu
		To select a menu item
9	UP/DOWN button	Short button stroke: Down or forwards
		Long button stroke: Up or back
10	Plug-in terminal for communication interfaces	Depending on meter type RS-485 (Modbus RTU) or M-Bus
11	Plug-in terminal for inputs and outputs	
12	Optical infrared interface (IR)	For internal use only!
13	Device seal	On both sides of the meter to protect against unauthorized opening of the meter
14	Lead-sealed cover	Protective cover with printed wiring diagram on the inside



MID ENERGY METERS – TECHNICAL DATA

	B21 alternating current meter	B23 three-phase meter	B24 Transformer meter
VOLTAGE/CURRENT INPUTS			
Nominal voltage	230 VAC	3 x 230/400 VAC	3 x 230/400 VAC
Voltage range	220 – 240 V AC (–20% – +15%)	3 x 220 – 240 VAC (–20% – +15%)	3 x 220 – 240 VAC (–20% – +15%)
Power dissipation of voltage circuits	1.0 VA (0.4 W) total	1.6 VA (0.7 W) total	1.6 VA (0.7 W) total
Power dissipation, circuits	0.007 VA (0.007 W) at 230 V AC and I_b	0.007 VA (0.007 W) per phase at 230 V AC and I_b	0.007 VA (0.007 W) per phase at 230 V AC and I_b
Reference current I_{ref}	5 A	5 A	1 A
Transient current I_{tr}	0.5 A	0.5 A	0.50 A
Maximum current I_{max}	65 A	65 A	6 A
Minimum current I_{min}	0.25 A	0.25 A	0.02 A
Starting current I_{st}	< 20 mA	< 20 mA	< 1 mA
Connection cross section	1 – 25 mm ²	1 – 25 mm ²	0.5 – 10 mm ²
Recommended tightening torque	3 Nm	3 Nm	1.5 Nm
TRANSFORMER RATIOS			
Configurable current ratio (CT)	–	–	9999/1-6
PULSE DISPLAY (LED)			
Pulse frequency	1000 pls/kWh	1000 pls/kWh	5000 pls/kWh
Pulse length	40 ms	40 ms	40 ms
GENERAL INFORMATION			
Frequency	50 or 60 Hz ± 5%	50 or 60 Hz ± 5%	50 or 60 Hz ± 5%
Accuracy class	B (Cl. 1) and reactive energy Cl. 2	B (Cl. 1) and reactive energy Cl. 2	B (Cl. 1) and reactive energy Cl. 2
Active energy	1%	1%	0.5%, 1%
Energy display	LCD with 6 digits	LCD with 7 digits	LCD with 7 digits
ENVIRONMENT			
Operating temperature	–40 °C – +70 °C	–40 °C – +70 °C	–40 °C – +70 °C
Storage temperature	–40 °C – +85 °C	–40 °C – +85 °C	–40 °C – +85 °C
Humidity	75% annual average, 95% on 30 days/year	75% annual average, 95% on 30 days/year	75% annual average, 95% on 30 days/year
Fire and heat resistance	Terminal 960 °C, Cover 650 °C (IEC 60695-2-1)	Terminal 960 °C, Cover 650 °C (IEC 60695-2-1)	Terminal 960 °C, Cover 650 °C (IEC 60695-2-1)
Water and dust resistance	IP20 on terminal blocks without protective housing and IP51 in protective housing, according to IEC 60529	IP20 on terminal blocks without protective housing and IP51 in protective housing, according to IEC 60529	IP20 on terminal blocks without protective housing and IP51 in protective housing, according to IEC 60529
Mechanical environment	Class M1 according to Measuring Instrument Directive (MID), (2004/22/EC)	Class M1 according to Measuring Instrument Directive (MID), (2004/22/EC)	Class M1 according to Measuring Instrument Directive (MID), (2004/22/EC)
Electromagnetic environment	Class E2 according to Measuring Instrument Directive (MID), (2004/22/EC)	Class E2 according to Measuring Instrument Directive (MID), (2004/22/EC)	Class E2 according to Measuring Instrument Directive (MID), (2004/22/EC)

	B21 alternating current meter	B23 three-phase meter	B24 Transformer meter
DIGITAL OUTPUT			
Current	2 – 100 mA	2 – 100 mA	2 – 100 mA
Voltage	24 V AC – 240 V AC, 24 V DC – 240 V DC For meters with only 1 output, 5 – 40 V DC	24 V AC – 240 V AC, 24 V DC – 240 V DC For meters with only 1 output, 5 – 40 V DC	24 V AC – 240 V AC, 24 V DC – 240 V DC For meters with only 1 output, 5 – 40 V DC
Output pulse frequency	Programmable: 1 - 999999 pls/kWh, pls/MWh	Programmable: 1 - 999999 pls/kWh, pls/MWh	Programmable: 1 - 999999 pls/kWh, pls/MWh
Pulse length	10 – 990 ms	10 – 990 ms	10 – 990 ms
Connection cross section	0.5 – 1 mm ²	0.5 – 1 mm ²	0.5 – 1 mm ²
Recommended tightening torque	0.25 Nm	0.25 Nm	0.25 Nm
DIGITAL INPUTS			
Voltage	0 – 240 V AC/DC	0 – 240 V AC/DC	0 – 240 V AC/DC
OFF	0 – 12 V AC/DC	0 – 12 V AC/DC	0 – 12 V AC/DC
ON	57 – 240 VAC/24 – 240 VDC	57 – 240 VAC/24 – 240 VDC	57 – 240 VAC/24 – 240 VDC
Minimum pulse length	30 ms	30 ms	30 ms
Connection cross section	0.5 – 1 mm ²	0.5 – 1 mm ²	0.5 – 1 mm ²
Recommended tightening torque	0.25 Nm	0.25 Nm	0.25 Nm
ELECTROMAGNETIC COMPATIBILITY			
Surge voltage test	6 kV 1.2/50 μs (IEC 60060-1)	6 kV 1.2/50 μs (IEC 60060-1)	6 kV 1.2/50 μs (IEC 60060-1)
Voltage swell test	4 kV 1.2/50 μs (IEC 61000-4-5)	4 kV 1.2/50 μs (IEC 61000-4-5)	4 kV 1.2/50 μs (IEC 61000-4-5)
Conducted transient	4 kV (IEC 61000-4-4)	4 kV (IEC 61000-4-4)	4 kV (IEC 61000-4-4)
Interference immunity to electromagnetic RF fields	80 MHz – 2 GHz (IEC 61000-4-6)	80 MHz – 2 GHz (IEC 61000-4-6)	80 MHz – 2 GHz (IEC 61000-4-6)
Interference immunity to conducted disturbances	150 kHz – 80 MHz (IEC 61000-4-6)	150 kHz – 80 MHz (IEC 61000-4-6)	150 kHz – 80 MHz (IEC 61000-4-6)
Interference immunity with harmonics	2 kHz – 150 kHz	2 kHz – 150 kHz	2 kHz – 150 kHz
High frequency emissions	EN 55022, Class B (CISPR22)	EN 55022, Class B (CISPR22)	EN 55022, Class B (CISPR22)
Electrostatic discharge	15 kV (IEC 61000-4-2)	15 kV (IEC 61000-4-2)	15 kV (IEC 61000-4-2)
Standards	IEC 62052-11, IEC 62053-21 Class 1 & 2, IEC 62053-22 Class 0.5S, IEC 62053-23 Class 2, IEC 62054-21, GB/T 17215.211-2006, GB/T 17215.312-2008 Class 1 & 2, GB/T 1725.322-2008 Class 0.5S, GB 4208-2008, EN 50470-3 Category A, B & C		
MECHANICAL			
Material	Polycarbonate in transparent front glass, lower and upper housing and terminal cover		
DIMENSIONS			
	35 X 97 X 65 MM (W X H X D)	70 X 97 X 65 MM (W X H X D)	70 X 97 X 65 MM (W X H X D)
DIN modules	2	4	4

REMOTE READING WITH A HIGHER-LEVEL PC

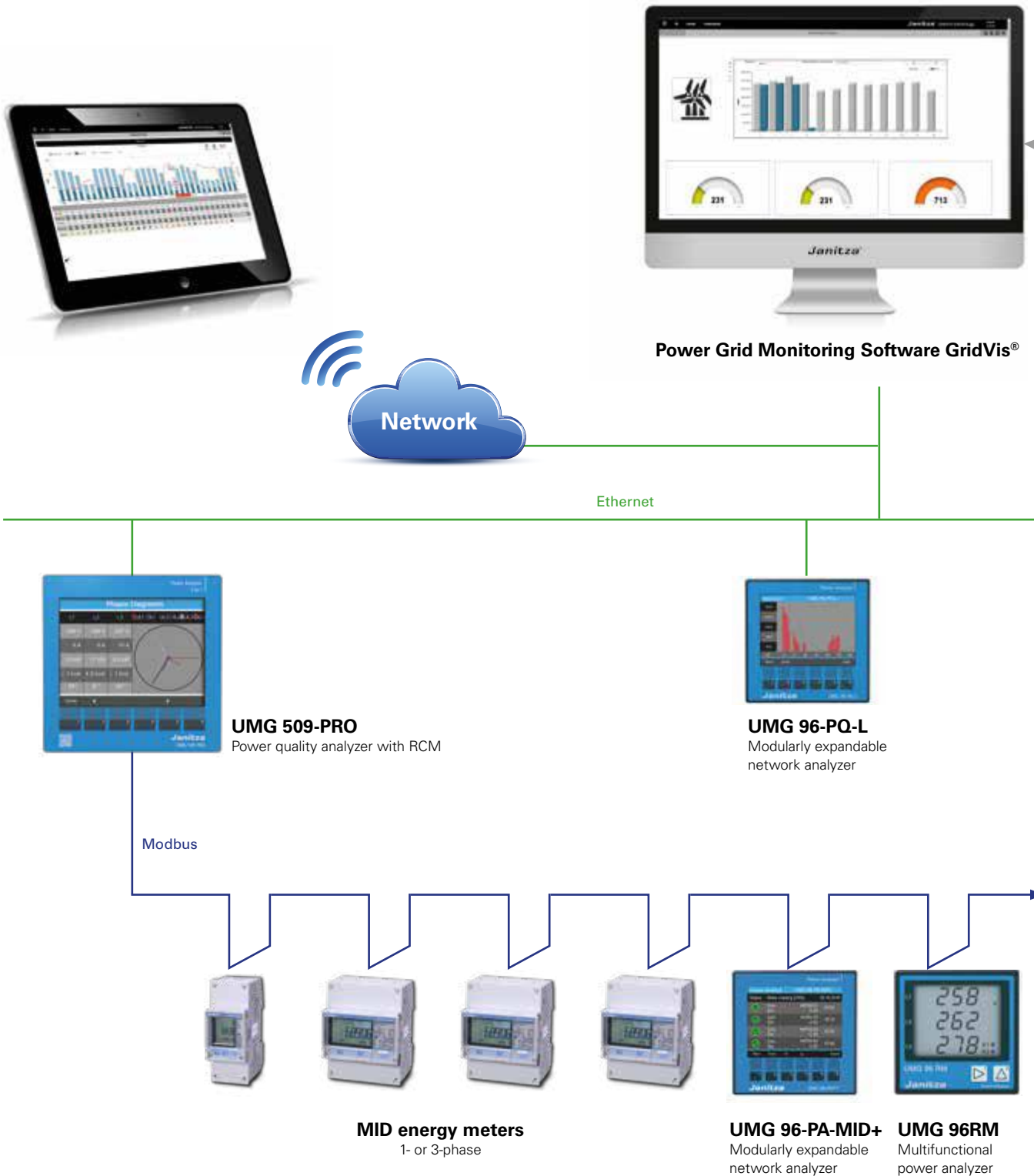

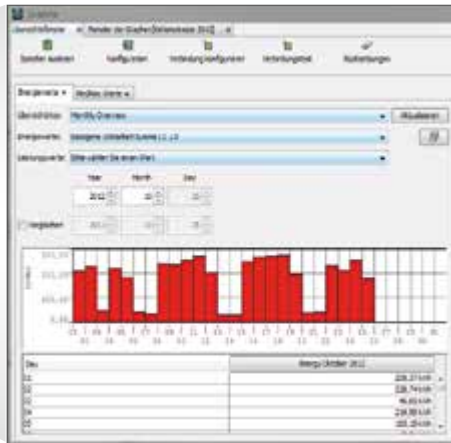

Tabular energy reports

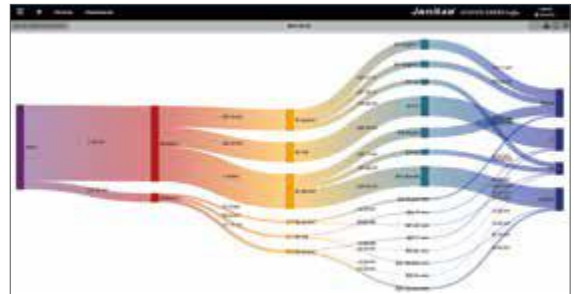

Sankey diagrams



Dashboard editor



UMG 604-PRO
Functionally expandable network analyzer

Modbus



MID energy meters
1- or 3-phase



ProData® Data Logger
Gateway for energy meters

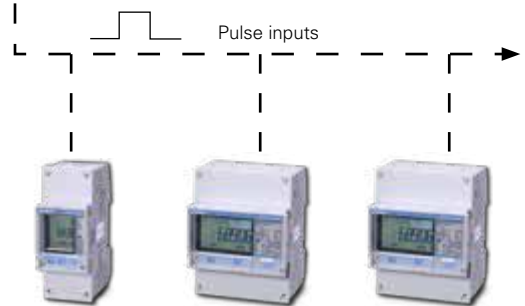

MID energy meters
1- or 3-phase

CURRENT TRANSFORMERS



Operating current transformers
Various designs,
classes and functions



Residual current transformer
Various residual current
types and designs



Accessories
Installation, communication
and supply

CURRENT TRANSFORMERS

Current transformers	187	Operating current transformers
	227	Residual current transformer
	247	Accessories

THE RIGHT CURRENT TRANSFORMER FOR EVERY APPLICATION

OPERATING CURRENT TRANSFORMERS



- 188** Plug-in current transformers
- 194** Plug-in current transformers for billing purposes
- 198** Small-signal transformer
- 200** Summation current transformer
- 204** Split core current transformer
- 208** Separable current transformers
- 210** Three-phase current transformers
- 212** DIN rail current transformers with voltage tap-off & back-up fuse
- 214** Compact current transformers
- 216** Split-core current transformers for the UMG 20CM
- 218** Separable operating current transformers up to 600 A
- 224** A flexible current transformer – The Rogowski coil

PLUG-IN CURRENT TRANSFORMER, CLASS 0.5 ... / 5 A

With plug-in current transformers, the conductor to be measured is fed through the opening, which is available in various diameters. The break proof plastic housings are flame retardant and self-extinguishing.

When installing plug-in current transformers, the primary conductor is interrupted, meaning they are mainly suitable for new installations.



PLUG-IN CURRENT TRANSFORMER, CLASS 0.5 – TECHNICAL DATA

PLUG-IN CURRENT TRANSFORMER, CLASS 0.5 ... / 5 A SECONDARY CURRENT*

TYPE	PRIMARY CURRENT in A	RATIO	POWER in VA	PRIMARY CONDUCTOR	ROUND CONDUCTOR in mm	WIDTH in mm	WEIGHT in kg	PART NO.
IPA40.5	60	60/5	2	40 x 10; 30 x 15; 25 x 20	30	70	0.6	0905349
IPA40.5	75	75/5	2	40 x 10; 30 x 15; 25 x 20	30	70	0.6	0905350
IPA40.5	100	100/5	2.5	40 x 10, 30 x 15; 25 x 20	30	70	0.5	0905351
IPA40.5	150	150/5	5	40 x 10, 30 x 15; 25 x 20	30	70	0.6	0905236
6A315.3	200	200/5	3.75	30 x 15, 20 x 20	28	60	0.3	0900360
6A315.3	250	250/5	5	30 x 15; 20 x 20	28	60	0.3	0900361
6A315.3	300	300/5	5	30 x 15; 20 x 20	28	60	0.3	0900362
6A315.3	400	400/5	5	30 x 15; 20 x 20	28	60	0.3	0900363
6A315.3	500	500/5	5	30 x 15; 20 x 20	28	60	0.3	0900364
6A315.3	600	600/5	5	30 x 15; 20 x 20	28	60	0.3	0900365
7A412.3	800	800/5	5	40 x 12; 2 x 30 x 10	33	70	0.4	0900887
7A412.3	1000	1000/5	5	40 x 12; 2 x 30 x 10	33	70	0.4	0900888
8A512.3	1.250	1250/5	5	50 x 12; 2 x 40 x 10	42	85	0.4	0901339
9A615.3	1.500	1500/5	5	63 x 15; 2 x 50 x 10	53	95	0.5	0901820
9A615.3	1.600	1600/5	5	63 x 15; 2 x 50 x 10	53	95	0.5	0901821
9A615.3	2.000	2000/5	5	63 x 15; 2 x 50 x 10	53	95	0.5	0901822
9A615.3	2.500	2500/5	5	63 x 15; 2 x 50 x 10	53	95	0.5	0901823

ACCESSORIES

Snap-on mounting for DIN rail EN 50022-35, suitable for design type 9A615.3, IPA40, 1 pair	0.01	0909000
Snap-on mounting for DIN rail EN 50022-35, suitable for design type 6A315.3, 7A412.3, 8A512.3 and 9A615.3, 1 pair	0.01	0909001
Snap-on mounting for DIN rail EN 50022-35, suitable for design type IPA40.5, 1 pair	0.01	0909002

* Secondary current transformer ... / 1 A and other types on request.

PLUG-IN CURRENT TRANSFORMER, CLASS 0.5 – DIMENSIONAL DRAWINGS

IPA40.5

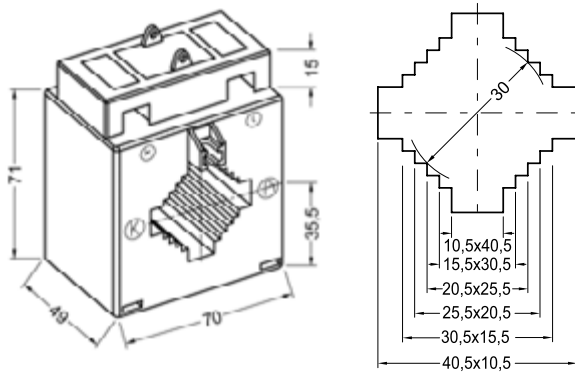

6A315.3

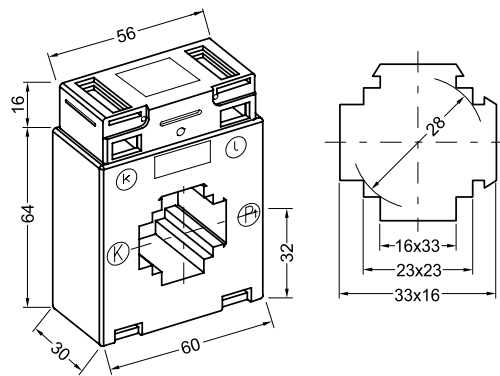

7A412.3

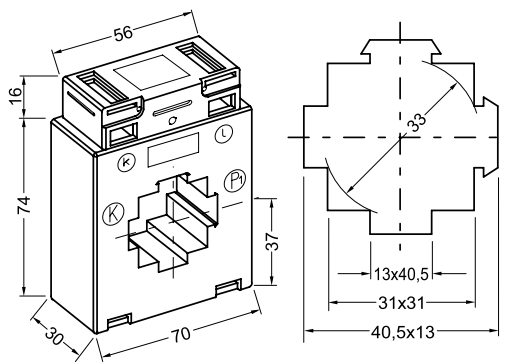

8A512.3

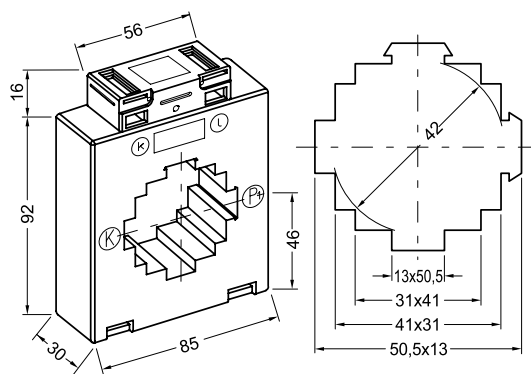

9A615.3

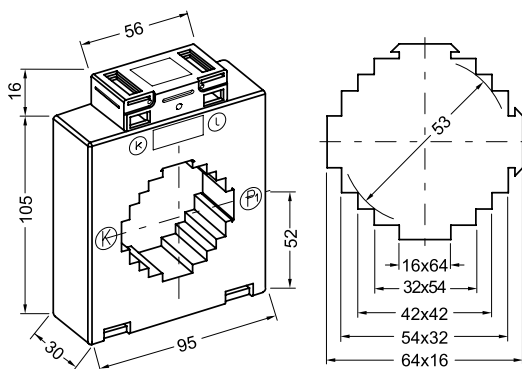

PLUG-IN CURRENT TRANSFORMERS CLASS 1 ... / 5 A

With plug-in current transformers, the conductor to be measured is fed through the opening, which is available in various diameters. The break proof plastic housings are flame retardant and self-extinguishing.

When installing plug-in current transformers, the primary conductor is interrupted, meaning they are mainly suitable for new installations.



PLUG-IN CURRENT TRANSFORMERS, CLASS 1 – TECHNICAL DATA

PLUG-IN CURRENT TRANSFORMER, CLASS 1 ... / 5 A SECONDARY CURRENT

TYPE	PRIMARY CURRENT in A	RATIO	POWER in VA	PRIMARY CONDUCTOR	ROUND CONDUCTOR in mm	WIDTH in mm	WEIGHT in kg	PART NO.
ASK 21.3	75	75/5	2.5	20 x 10	19.2	61	0.31	1503206
ASK 21.3	80	80/5	2.5	20 x 10	19.2	61	0.32	1503207
ASK 21.3	100	100/5	3.75	20 x 10	19.2	61	0.26	1503208
ASK 31.5	75	75/5	1.5	30 x 10; 20 x 10	28	61	0.45	1503270
CTB 31.35	100	100/5	2.5	30 x 10; 25 x 12; 20 x 20	25.7	60	0.23	1503272
CTB 31.35	150	150/5	2.5	30 x 10; 25 x 12; 20 x 20	25.7	60	0.23	1503273
CTB 31.35	200	200/5	2.5	30 x 10; 25 x 12; 20 x 20	25.7	60	0.23	1503274
CTB 31.35	250	250/5	5	30 x 10; 25 x 12; 20 x 20	25.7	60	0.23	1503275
CTB 31.35	300	300/5	5	30 x 10; 25 x 12; 20 x 20	25.7	60	0.23	1503276
CTB 31.35	400	400/5	5	30 x 10; 25 x 12; 20 x 20	25.7	60	0.23	1503277
CTB 31.35	500	500/5	5	30 x 10; 25 x 12; 20 x 20	25.7	60	0.23	1503278
ASK 31.3	600	600/5	5	30 x 10; 20 x 20	26	61	0.25	1503279
CTB 41.35	800	800/5	5	40 x 10; 30 x 15	31.8	70	0.30	1503280
CTB 41.35	1000	1000/5	5	40 x 10; 30 x 15	31.8	70	0.30	1503281
CTB 51.35	1250	1250/5	5	50 x 12; 40 x 30	43.7	85	0.35	1503282
CTB 61.35	1500	1500/5	5	63 x 10; 50 x 30	43.7	95	0.35	1503283
CTB 81.35	1500	1500/5	10	80 x 10; 60 x 30	54.7	120	0.35	1503284
CTB 81.35	1600	1600/5	10	80 x 10; 60 x 30	54.7	120	0.35	1503285
CTB 81.35	2000	2000/5	10	80 x 10; 60 x 30	54.7	120	0.38	1503286
CTB 101.35	2500	2500/5	10	100 x 10; 80 x 30	70	130	0.40	1503287

ACCESSORIES

Snap-on mounting for design type CTB	1502140
Snap-on mounting for design type ASK 31.5	1502141
Snap-on mounting for design type ASK 31.3	1502151

PLUG-IN CURRENT TRANSFORMERS, CLASS 1 – DIMENSIONAL DRAWINGS

ASK 21.3

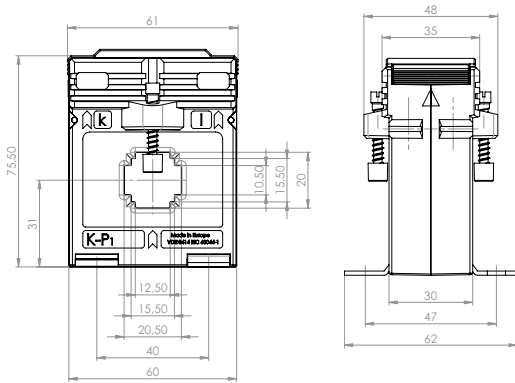

ASK 31.3

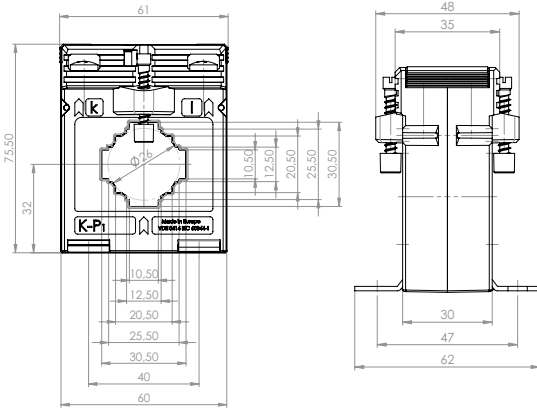

ASK 31.5

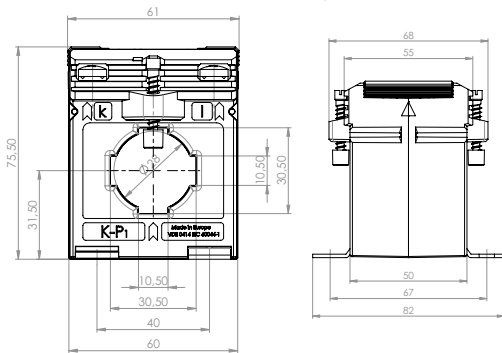

CTB 31.35

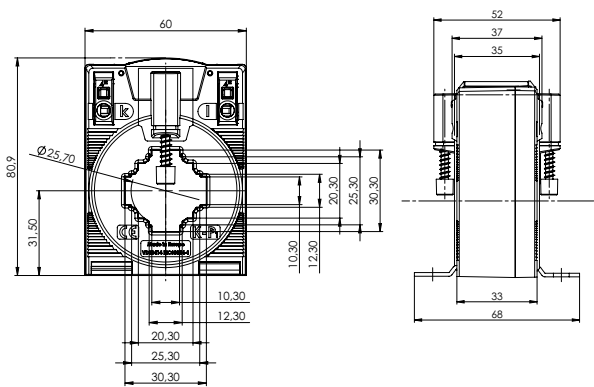

CTB 41.35

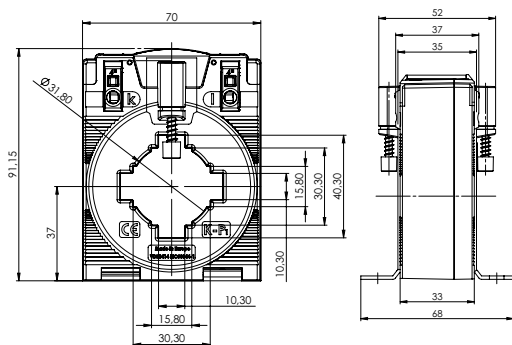

CTB 51.35

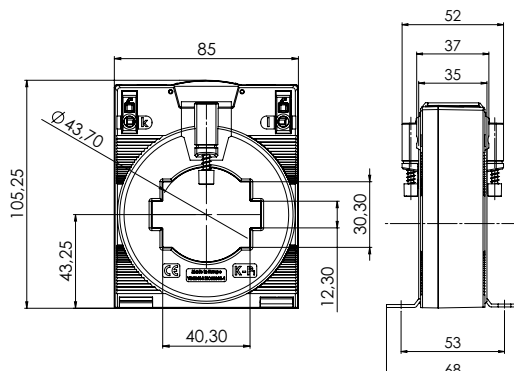

CTB 61.35

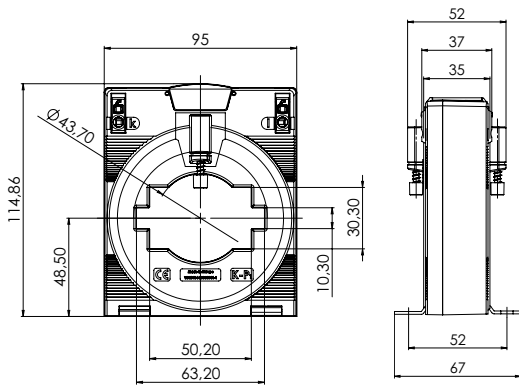

CTB 81.35

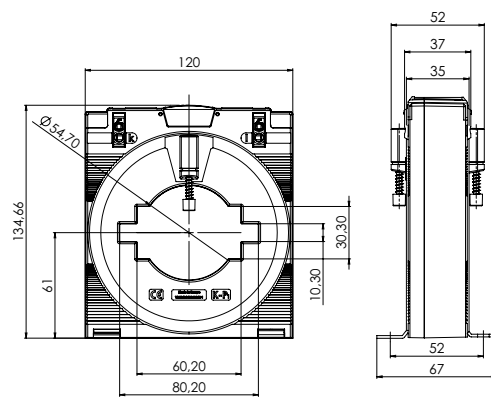

CTB 101.35

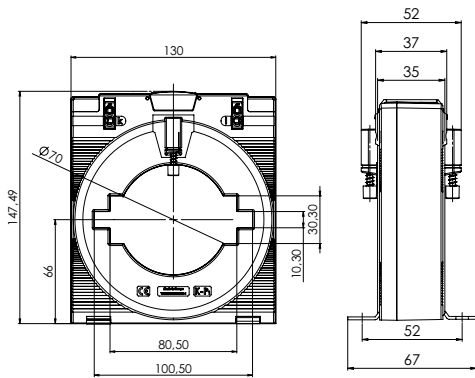

PLUG-IN CURRENT TRANSFORMERS FOR BILLING PURPOSES, CLASS 0.5 ... / 5 A

Current transformers for billing can be used to meet applicable regulations for kWh meters. The transformers are available in various ratios and with different diameters.



PLUG-IN CURRENT TRANSFORMERS FOR BILLING PURPOSES – TECHNICAL DATA

PLUG-IN CURRENT TRANSFORMERS FOR BILLING PURPOSES, CLASS 0.5 ... / 5 A SECONDARY CURRENT*

TYPE	PRIMARY CURRENT in A	RATIO	POWER in VA	PRIMARY CONDUCTOR	ROUND CONDUCTOR in mm	WIDTH in mm	WEIGHT in kg	PART NO.
EIPA30.5	50	50/5	2.5	30.5 x 10.5; 20.5 x 20.5; 10.5 x 30.5	23	70	0.4	0914813
EIPA30.5	75	75/5	2.5	30.5 x 10.5; 20.5 x 20.5; 10.5 x 30.5	23	70	0.4	0914812
EIPA30.5	100	100/5	2.5	30.5 x 10.5; 20.5 x 20.5; 10.5 x 30.5	23	70	0.3	0914811
E6A315.3	150	150/5	2.5	33 x 16; 23 x 23, 16 x 33	28	60	0.3	0910339
E6A315.3	200	200/5	2.5	33 x 16; 23 x 23, 16 x 33	28	60	0.3	0910340
E6A315.3	250	250/5	5	33 x 16; 23 x 23, 16 x 33	28	60	0.3	0910367
E6A315.3	300	300/5	5	33 x 16; 23 x 23, 16 x 33	28	60	0.3	0910366
E6A315.3	400	400/5	5	33 x 16; 23 x 23, 16 x 33	28	60	0.3	1502907
E6A315.3	500	500/5	5	33 x 16; 23 x 23, 16 x 33	28	60	0.3	0910364
E6A315.3	600	600/5	5	33 x 16; 23 x 23, 16 x 33	28	60	0.3	0911365
E7A412.3	750	750/5	5	40.5 x 13; 31 x 31, 13 x 40.5	33	70	0.3	0910391
E7A412.3	1000	1000/5	5	40.5 x 13; 31 x 31, 13 x 40.5	33	70	0.4	0910888
E9A615.3	1.500	1500/5	5	64 x 16; 54 x 32; 42 x 42; 32 x 54; 16 x 64	53	95	0.4	0910387
E13A1030.3	2.000	2000/5	5	101 x 31; 84 x 64; 54 x 81	85	129	0.5	0912888
E13A1030.3	2.500	2500/5	5	101 x 31; 84 x 64; 54 x 81	85	129	0.5	0912889

ACCESSORIES

Declaration of conformity with errata

[0950011](#)

* Transformers are made to order, no stock items, returns excluded. Current transformers with other primary or secondary currents on request.

PLUG-IN CURRENT TRANSFORMERS FOR BILLING PURPOSES – DIMENSIONAL DRAWINGS

EIPA30.5

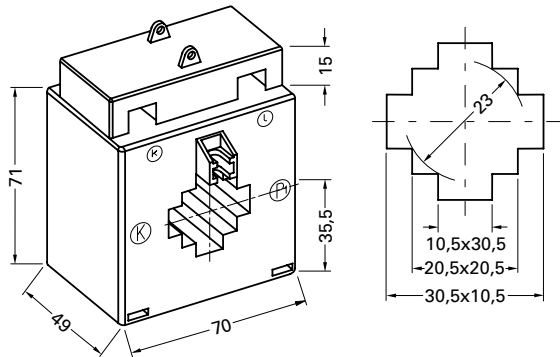

E6A315.3

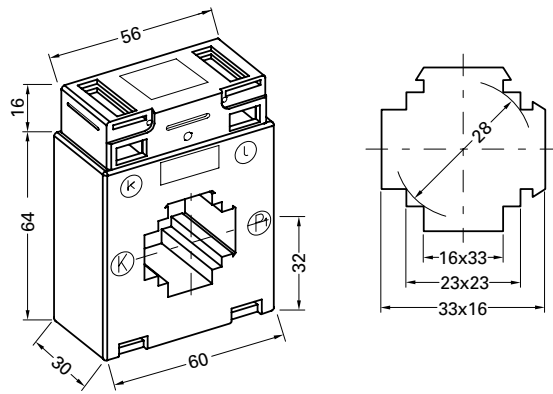

E7A412.3

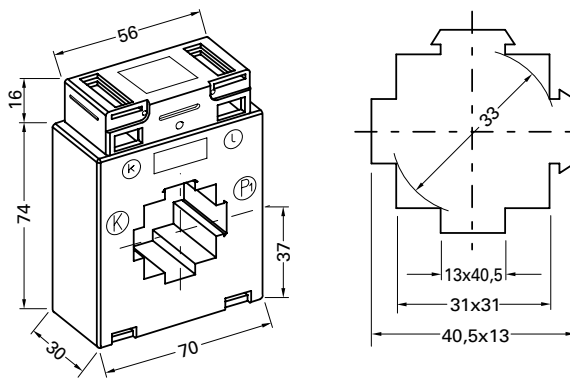

E9A615.3

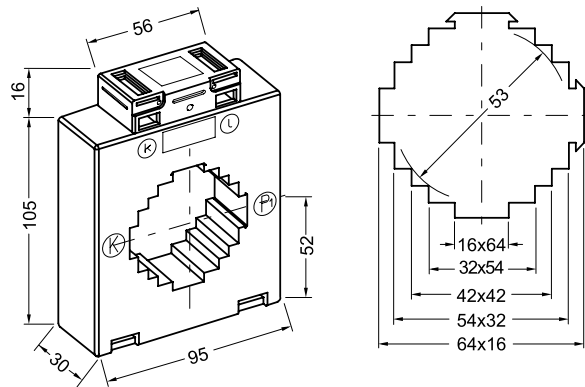

E13A1030.3

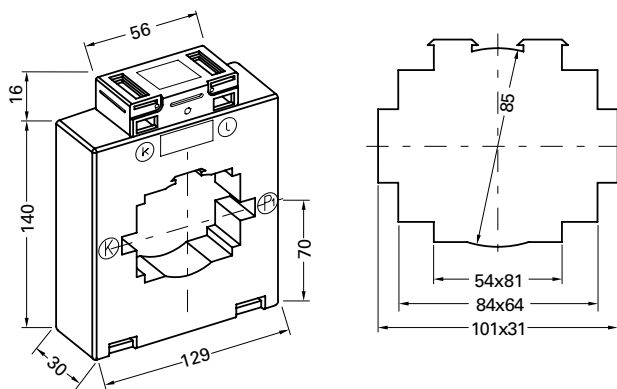

PLUG-IN CURRENT TRANSFORMERS FOR BILLING PURPOSES, CLASS 0.2S ... / 5 A

Current transformers for billing can be used to meet applicable regulations for kWh meters. The transformers are available in various ratios and with different diameters.



PLUG-IN CURRENT TRANSFORMERS FOR BILLING PURPOSES – TECHNICAL DATA

PLUG-IN CURRENT TRANSFORMERS FOR BILLING PURPOSES, CLASS 0.2S ... / 5 A SECONDARY CURRENT*

TYPE	PRIMARY CURRENT in A	RATIO	POWER in VA	PRIMARY CONDUCTOR	ROUND CONDUCTOR in mm	HEIGHT in mm	WIDTH in mm	WEIGHT in kg	PART NO.
ERM60-E3A	150	150/5	1 VA	30 x 10	24.5	30	60	0.4	0906212
ERM60-E3A	200	200/5	2 VA	30 x 10	24.5	30	60	0.4	0906213
ERM60-E3A	250	250/5	2.5 VA	30 x 10	24.5	30	60	0.4	0906214
ERM70-E4A	300	300/5	2.5 VA	40 x 10	30.5	30	70	0.4	0906215
ERM70-E4A	400	400/5	5 VA	40 x 10	30.5	30	70	0.4	0906216
ERM70-E4A	500	500/5	5 VA	40 x 10	30.5	30	70	0.4	0906217
ERM70-E4B	600	600/5	5 VA	40 x 10	30.5	50	70	0.5	0906218
ERM70-E4B	750	750/5	5 VA	40 x 10	30.5	50	70	0.5	0906219
ERM85-E6A	1000	1000/5	5 VA	60 x 10	30.6	40	85	0.6	0906220

ACCESSORIES

Snap-on mounting for ERM60/ERM70

0909012

* Transformers are made to order, no stock items, returns excluded.

PLUG-IN CURRENT TRANSFORMERS FOR BILLING PURPOSES – DIMENSIONAL DRAWINGS

ERM60-E2A

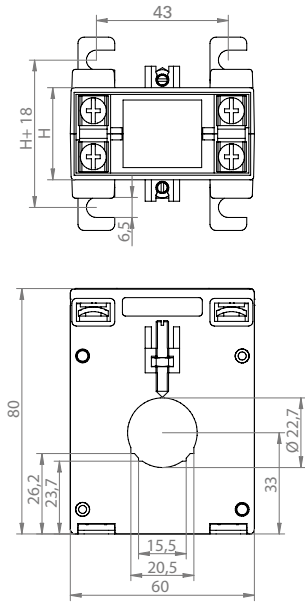

ERM60-E3A

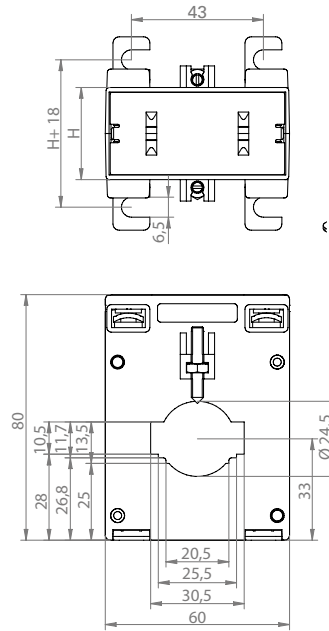

ERM70-E4A

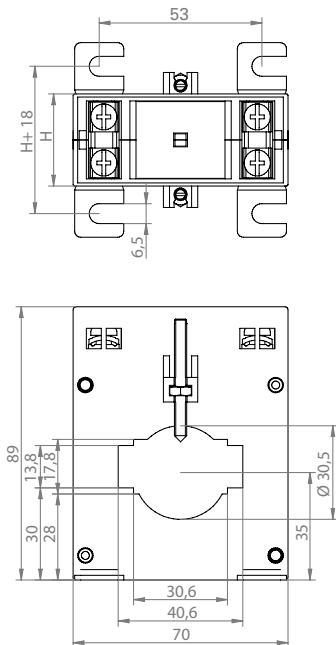

ERM85-E6A

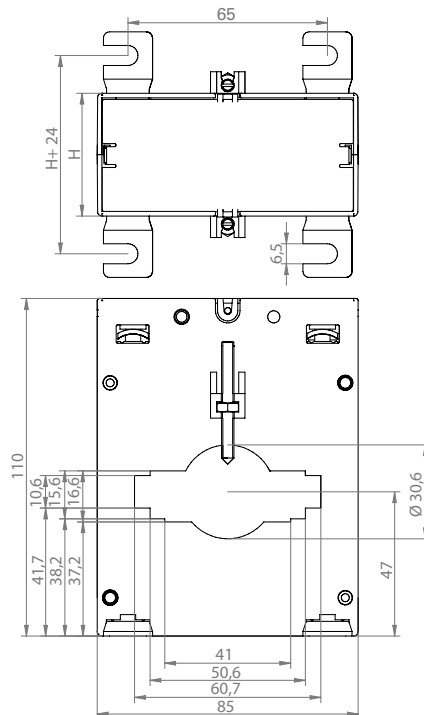

SMALL-SIGNAL TRANSFORMERS, CLASS 0.5... / 0.1 A

The small-signal transformer is a plug-in current transformer with very low secondary current. This makes it particularly safe if touched.



SMALL-SIGNAL TRANSFORMERS – TECHNICAL DATA

SMALL-SIGNAL TRANSFORMERS, CLASS 0.5 / 0.1 A SECONDARY CURRENT

TYPE	PRIMARY CURRENT in A	RATIO	POWER in VA	PRIMARY CONDUCTOR	ROUND CONDUCTOR in mm	WIDTH in mm	WEIGHT in kg	PART NO.
ASR 20.3	150	150/0.1	1.5	–	21	45	0.30	1503200
ASK 41.4	250	250/0.1	1.5	40 x 10; 2 x 30 x 5	32	71	0.36	1503210
ASK 41.4	400	400/0.1	1.5	40 x 10; 2 x 30 x 5	32	71	0.40	1503215
CTB 31.35	150	150/0.1	1.5	30 x 10; 25 x 12; 20 x 20	25.7	60	0.40	1503220
CTB 41.35	250	250/0.1	1.5	40 x 10; 30 x 15	31.8	70	0.40	1503225
CTB 41.35	400	400/0.1	1.5	40 x 10; 30 x 15	31.8	70	0.40	1503230

ACCESSORIES

Snap-on mounting for ASR 20.3	1502143
Snap-on mounting for ASK 41.4	1502142
Snap-on mounting for CTB	1502140

SINGLE ACCESSORIES (loads are included in the scope of delivery with the transformers)

Load (0.8 Ω) for operating current transformers with 1.5 m connection cable and spring terminal	1503085
---	-------------------------

SMALL-SIGNAL TRANSFORMERS – DIMENSIONAL DRAWINGS

ASR 20.3

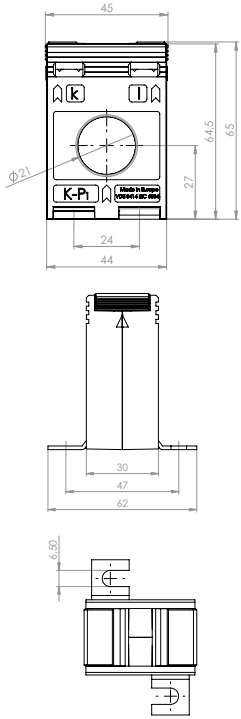

ASK 41.4

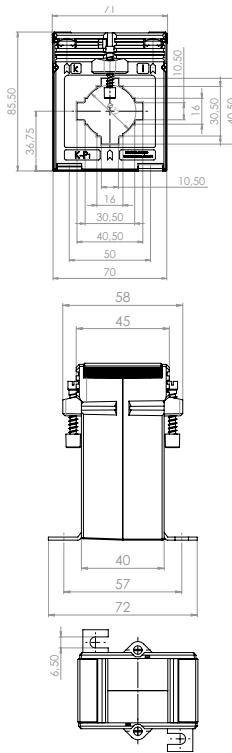

CTB 31.35

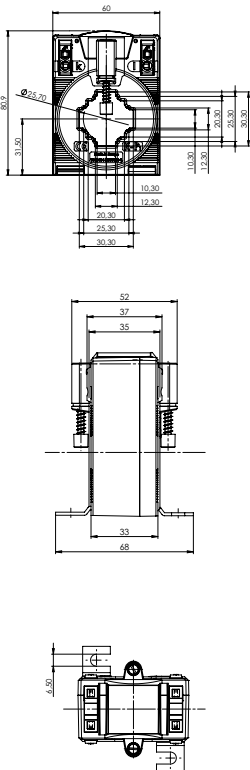

CTB 41.35

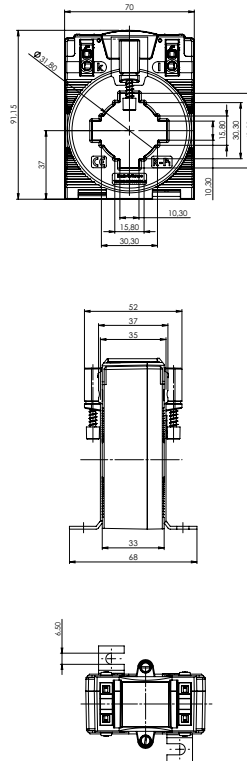

SUMMATION CURRENT TRANSFORMERS FOR PLUG-IN & SPLIT TRANSFORMERS, CLASS 1 & CLASS 0.5

With summation current transformers, the total consumption can be recorded by only one measurement device, even if the measurement is made via two or more current transformers. The summation current transformer adds up the secondary signals of the individual current transformers and makes them available as a normalized measurement signal.



SUMMATION CURRENT TRANSFORMERS FOR PLUG-IN & SPLIT TRANSFORMERS – TECHNICAL DATA

SUMMATION CURRENT TRANSFORMERS FOR PLUG-IN & SPLIT TRANSFORMERS, CLASS 1

TYPE	PRIMARY CURRENT in A	SECONDARY CURRENT in A	RATIO	POWER in VA	DIMENSIONS in mm (W x H x D)	WEIGHT in kg	PART NO.
IPS20	5+5	5	1/1	15	45 x 115 x 73	0.4	1502510
IPS30	5+5+5	5	1/1/1	15	45 x 115 x 73	0.4	1502515
IPS40	5+5+5+5	5	1/1/1/1	15	45 x 115 x 73	0.5	1502520
IPS20	1+1	1	1/1	15	45 x 115 x 73	0.5	0905306
IPS30	1+1+1	1	1/1/1	15	45 x 115 x 73	0.5	0905316
IPS40	1+1+1+1	1	1/1/1/1	15	45 x 115 x 73	0.5	0905326
IPS21	5+5	5	Customer-specific	15	45 x 115 x 73	0.4	1502526
IPS31	5+5+5	5	Customer-specific	15	45 x 115 x 73	0.4	1502521
IPS41	5+5+5+5	5	Customer-specific	10	45 x 115 x 73	0.5	1502525

SUMMATION CURRENT TRANSFORMERS FOR PLUG-IN & SPLIT TRANSFORMERS, CLASS 0.5

TYPE	PRIMARY CURRENT in A	SECONDARY CURRENT in A	RATIO	POWER in VA	DIMENSIONS in mm (W x H x D)	WEIGHT in kg	PART NO.
IPS20	5+5	5	1:1	15	45 x 115 x 73	0.5	1502511
IPS30	5+5+5	5	1:1:1	15	45 x 115 x 73	0.5	1502516
IPS40	5+5+5+5	5	1:1:1:1	15	45 x 115 x 73	0.5	1502519

Not to be used in conjunction with split core current transformers.

SUMMATION CURRENT TRANSFORMERS FOR PLUG-IN & SPLIT TRANSFORMERS – DIMENSIONAL DRAWINGS

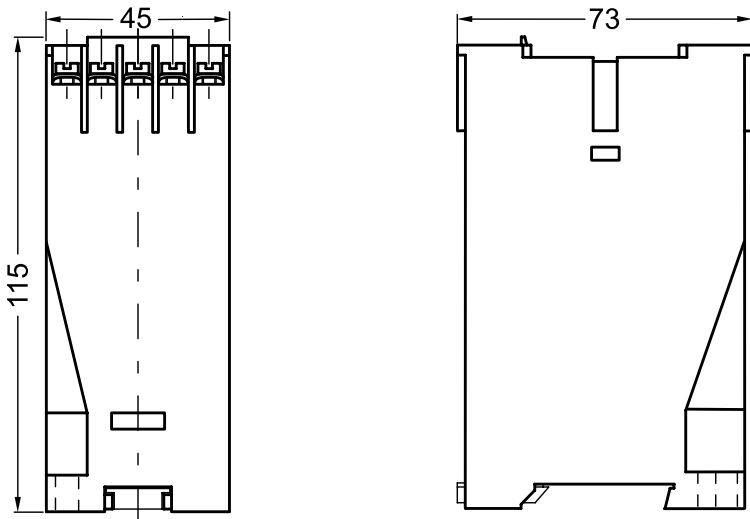

SUMMATION CURRENT TRANSFORMERS FOR SPLIT CORE TRANSFORMERS, CLASS 1

With summation current transformers, the total consumption can be recorded by only one measurement device, even if the measurement is made via two or more current transformers. The summation current transformer adds up the secondary signals of the individual current transformers and makes them available as a normalized measurement signal.



SUMMATION CURRENT TRANSFORMERS FOR SPLIT CORE TRANSFORMERS – TECHNICAL DATA

SUMMATION CURRENT TRANSFORMERS FOR SPLIT CORE TRANSFORMERS, CLASS 1

TYPE	PRIMARY CURRENT in A	SECONDARY CURRENT in A	RATIO	POWER in VA	DIMENSIONS in mm (W x H x D)	WEIGHT in kg	PART NO.
STS20	1+1	1	1:1	0.2	30 x 80 x 60	0.2	1502560
STS30	1+1+1	1	1:1:1	0.2	30 x 80 x 60	0.2	1502561
STS40	1+1+1+1	1	1:1:1:1	0.2	55 x 80 x 60	0.4	1502562
STS50	1+1+1+1+1	1	1:1:1:1:1	0.2	55 x 80 x 60	0.4	1502563
STS60	1+1+1+1+1+1	1	1:1:1:1:1:1	0.2	55 x 80 x 60	0.4	1502564
STS21	1+1	1	Customer-specific	0.2	30 x 80 x 60	0.2	1502570
STS31	1+1+1	1	Customer-specific	0.2	30 x 80 x 60	0.2	1502571
STS41	1+1+1+1	1	Customer-specific	0.2	55 x 80 x 60	0.4	1502572
STS51	1+1+1+1+1	1	Customer-specific	0.2	55 x 80 x 60	0.4	1502573
STS61	1+1+1+1+1+1	1	Customer-specific	0.2	55 x 80 x 60	0.4	1502574

For unequal main transformers, the ratio of the largest to the smallest primary current should not be greater than 10/1.

SUMMATION CURRENT TRANSFORMERS FOR SPLIT CORE TRANSFORMERS – DIMENSIONAL DRAWINGS

STS20 / STS30 / STS21 / STS31

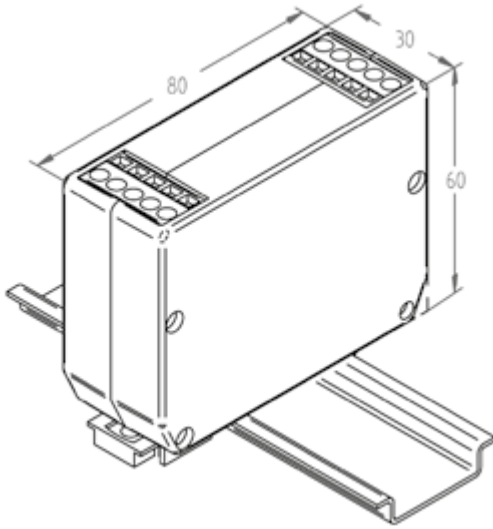

STS40 / STS50 / STS60 / STS41 / STS51 / STS61

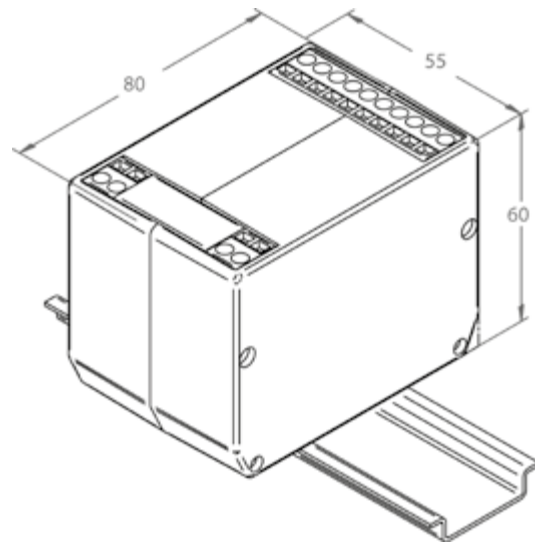

SPLIT CORE CURRENT TRANSFORMERS, CLASS 0.5, 1 AND 3

Split core current transformers are particularly suitable for retrofitting, since their installation does not require the primary circuit to be interrupted. They are quick and easy to install and are available in the types KUW and KBU.



SPLIT CORE CURRENT TRANSFORMER – TECHNICAL DATA

SPLIT CORE CURRENT TRANSFORMERS – KUW1 SERIES FOR INSULATED CABLES UP TO MAX. 18 MM IN DIAMETER

TYPE	PRIMARY CURRENT in A	SECONDARY CURRENT in A	POWER in VA	CLASS	CABLE LENGTH in m	Ø OF PRIMARY CONDUCTOR in mm	WEIGHT in kg	PART NO.
KUW1/30-60	60	1	0.2	3	3	18	0.3	1503510
KUW1/30-75	75	1	0.2	3	3	18	0.3	1503511
KUW1/30-100	100	1	0.2	3	3	18	0.3	1503512
KUW1/30-125	125	1	0.2	3	3	18	0.3	1503513
KUW1/30-150	150	1	0.2	3	3	18	0.3	1503514
KUW1/30-200	200	1	0.2	1	3	18	0.3	1503515
KUW1/30-250	250	1	0.2	1	3	18	0.3	1503317
KUW1/40-100	100	1	0.2	1	3	18	0.4	1503320
KUW1/40-125	125	1	0.2	1	3	18	0.4	1503321
KUW1/40-150	150	1	0.2	1	3	18	0.4	1503322
KUW1/40-200	200	1	0.2	0.5	3	18	0.4	1503325
KUW1/40-250	250	1	0.2	0.5	3	18	0.4	1503326
KUW1/40-150	150	5	1	1	0.5	18	0.4	1503329
KUW1/40-200	200	5	1	1	0.5	18	0.4	1503330
KUW1/40-250	250	5	1	0.5	0.5	18	0.4	1503331

SPLIT CORE CURRENT TRANSFORMERS – KUW2 SERIES FOR INSULATED CABLES OF MAX. 28 MM IN DIAMETER

TYPE	PRIMARY CURRENT in A	SECONDARY CURRENT in A	POWER in VA	CLASS	CABLE LENGTH in m	Ø OF PRIMARY CONDUCTOR in mm	WEIGHT in kg	PART NO.
KUW2/40-200	200	1	0.2	1	3	28	0.3	1503351
KUW2/40-250	250	1	0.2	1	3	28	0.3	1503352
KUW2/40-300	300	1	0.2	1	3	28	0.3	1503354
KUW2/40-400	400	1	0.2	1	3	28	0.4	1503356
KUW2/40-500	500	1	0.2	0.5	3	28	0.4	1503358
KUW2/40-250	250	5	1	1	0.5	28	0.3	1503353
KUW2/40-300	300	5	1	1	0.5	28	0.3	1503355
KUW2/40-400	400	5	1	1	0.5	28	0.3	1503357
KUW2/40-500	500	5	1	1	0.5	28	0.3	1503359

SPLIT CORE CURRENT TRANSFORMERS – KUW4/60 SERIES FOR INSULATED CABLES UP TO MAX. 42 MM IN DIAMETER

TYPE	PRIMARY CURRENT in A	SECONDARY CURRENT in A	POWER in VA	CLASS	CABLE LENGTH in m	Ø OF PRIMARY CONDUCTOR in mm	WEIGHT in kg	PART NO.
KUW4/60-250	250	1	0.5	1	5	42	0.6	1503565
KUW4/60-300	300	1	0.5	1	5	42	0.6	1503566
KUW4/60-400	400	1	0.5	0.5	5	42	0.6	1503568
KUW4/60-500	500	1	0.5	0.5	5	42	0.6	1503570
KUW4/60-600	600	1	0.5	0.5	5	42	0.6	1503572
KUW4/60-750	750	1	0.5	0.5	5	42	0.6	1503574
KUW4/60-800	800	1	0.5	0.5	5	42	0.6	1503576
KUW4/60-1000	1000	1	0.5	0.5	5	42	0.6	1503578
KUW4/60-300	300	5	0.5	1	3	42	0.6	1503367
KUW4/60-400	400	5	0.5	1	3	42	0.6	1503369
KUW4/60-500	500	5	0.5	1	3	42	0.6	1503371
KUW4/60-600	600	5	0.5	0.5	3	42	0.6	1503373
KUW4/60-750	750	5	0.5	0.5	3	42	0.6	1503375
KUW4/60-800	800	5	0.5	0.5	3	42	0.6	1503377
KUW4/60-1000	1000	5	0.5	0.5	3	42	0.6	1503379

SPLIT CORE CURRENT TRANSFORMERS – KUW4.2/60 SERIES FOR INSULATED CABLES UP TO MAX. 2 X 42 MM IN DIAMETER

TYPE	PRIMARY CURRENT in A	SECONDARY CURRENT in A	POWER in VA	CLASS	CABLE LENGTH in m	Ø OF PRIMARY CONDUCTOR in mm	WEIGHT in kg	PART NO.
KUW4.2/60-250	250	1	0.5	1	5	42 x 84	0.7	1503580
KUW4.2/60-300	300	1	0.5	1	5	42 x 84	0.8	1503581
KUW4.2/60-400	400	1	0.5	0.5	5	42 x 84	0.7	1503583
KUW4.2/60-500	500	1	0.5	0.5	5	42 x 84	0.8	1503585
KUW4.2/60-600	600	1	0.5	0.5	5	42 x 84	0.7	1503587
KUW4.2/60-750	750	1	0.5	0.5	5	42 x 84	0.8	1503589
KUW4.2/60-800	800	1	0.5	0.5	5	42 x 84	0.8	1503591
KUW4.2/60-1000	1000	1	0.5	0.5	5	42 x 84	0.8	1503593
KUW4.2/60-300	300	5	0.5	1	3	42 x 84	0.7	1503382
KUW4.2/60-400	400	5	0.5	1	3	42 x 84	0.8	1503384
KUW4.2/60-500	500	5	0.5	1	3	42 x 84	0.6	1503386
KUW4.2/60-600	600	5	0.5	0.5	3	42 x 84	0.7	1503388
KUW4.2/60-750	750	5	0.5	0.5	3	42 x 84	0.8	1503390
KUW4.2/60-800	850	5	0.5	0.5	3	42 x 84	0.8	1503392
KUW4.2/60-1000	1000	5	0.5	0.5	3	42 x 84	0.8	1503394

SPLIT CORE CURRENT TRANSFORMER – DIMENSIONAL DRAWINGS

KUW1/30

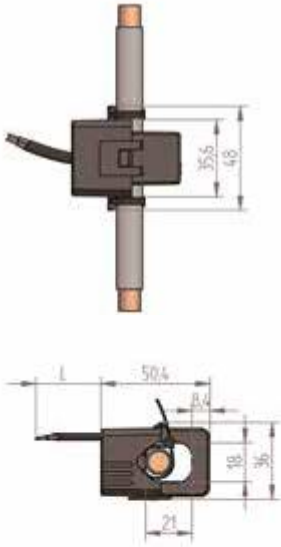

KUW1/40

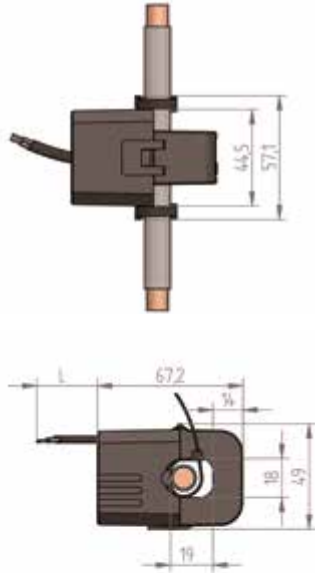

KUW2/40

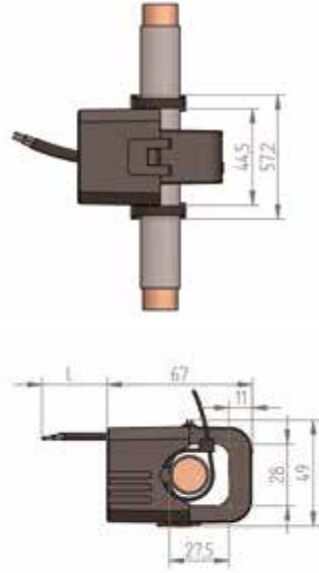

KUW4/60

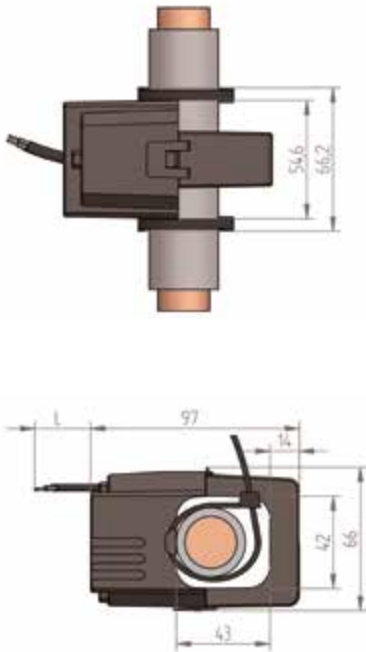

KUW4.2/60

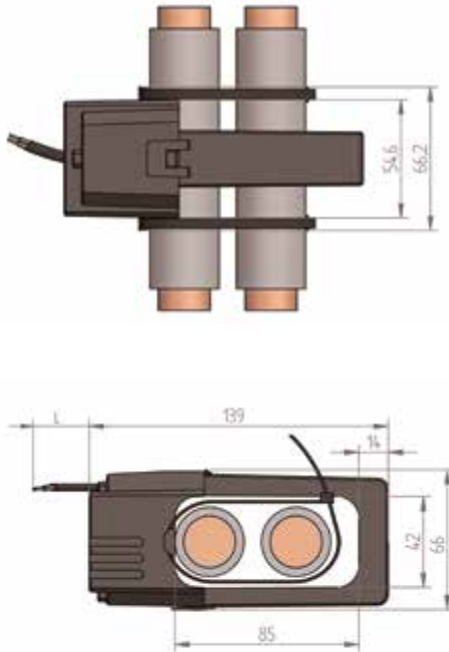



SEPARABLE CURRENT TRANSFORMERS, TYPE KBU, CLASS 0.5 AND 1

Separable current transformers are particularly suitable for retrofitting, as they can also be installed during operation and without interrupting the primary conductor. They are available in the model type KBU.



SEPARABLE CURRENT TRANSFORMERS, TYPE KBU – TECHNICAL DATA

SEPARABLE CURRENT TRANSFORMERS, TYPE KBU – KUW1 SERIES FOR INSULATED CABLES UP TO MAX. 18 MM IN DIAMETER

TYPE	PRIMARY CURRENT in A	SECONDARY CURRENT in A	POWER in VA	CLASS	DIMENSIONS in mm					WEIGHT in kg	PART NO.
					A	B	C / C1	D	E		
KBU 58	250	5	1.5	1	125	158	34 / 58	55	85	0.9	1502316
KBU 58	400	5	1	0.5	125	158	34 / 58	55	85	0.9	1502868
KBU 58	500	5	2.5	0.5	125	158	34 / 58	55	85	0.9	1502819
KBU 58	600	5	2.5	0.5	125	158	34 / 58	55	85	1.0	1502315
KBU 58	1000	5	5	0.5	125	158	34 / 58	55	85	1.0	1502320
KBU 812	600	5	2.5	0.5	155	198	34 / 58	85	125	1.3	1502869
KBU 812	800	5	2.5	0.5	155	198	34 / 58	85	125	1.3	1502870
KBU 812	1000	5	5	0.5	155	198	34 / 58	85	125	1.3	1502871
KBU 812	1250	5	7.5	0.5	155	198	34 / 58	85	125	1.3	1502328

SEPARABLE CURRENT TRANSFORMERS, TYPE KBU – DIMENSIONAL DRAWINGS

KBU 58

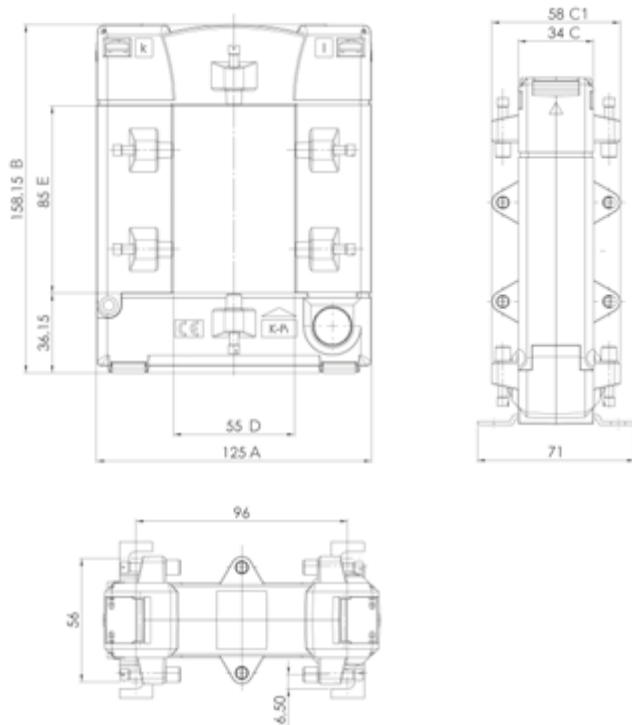

KBU 812

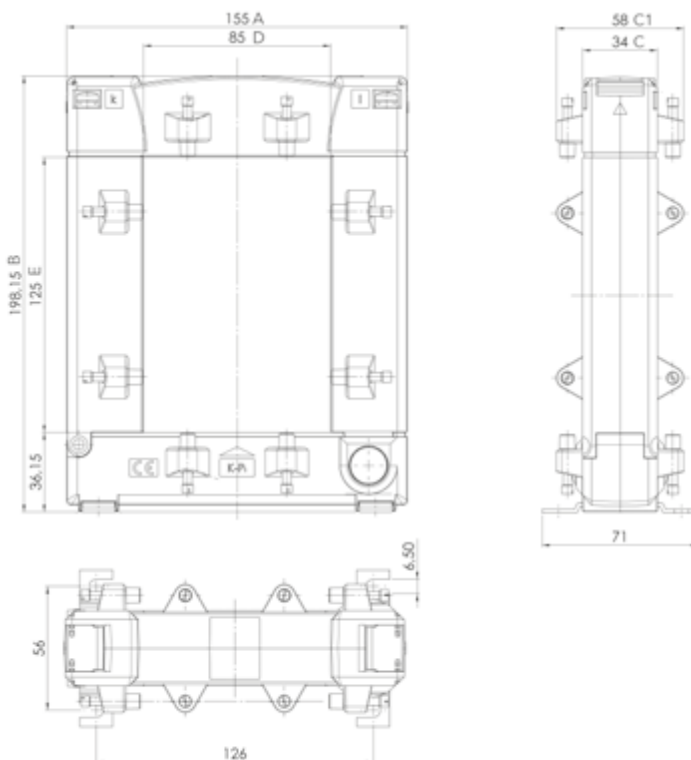

THREE-PHASE CURRENT TRANSFORMERS, TYPE ASRD 14, CLASS 0.5 AND 1

This three-phase current transformer is ideally suited for DIN rail mounting and has low space requirements due to its compact design.



THREE-PHASE CURRENT TRANSFORMER – TECHNICAL DATA

THREE-PHASE CURRENT TRANSFORMER, TYPE ASRD 14

TYPE	PRIMARY CURRENT in A	SECONDARY CURRENT in A	POWER in VA	CLASS	ROUND CONDUCTOR in m	DIMENSIONS in mm (W x H x D)	WEIGHT in kg	PART NO.
ASRD 14	50	5	1	1	13.5	105 x 90 x 54	0.5	1503403
ASRD 14	75	5	1.5	1	13.5	105 x 90 x 54	0.5	1503404
ASRD 14	100	5	2.5	1	13.5	105 x 90 x 54	0.5	1503405
ASRD 14	125	5	2.5	0.5	13.5	105 x 90 x 54	0.5	1503406
ASRD 14	150	5	2.5	0.5	13.5	105 x 90 x 54	0.5	1503407

THREE-PHASE CURRENT TRANSFORMERS – DIMENSIONAL DRAWINGS

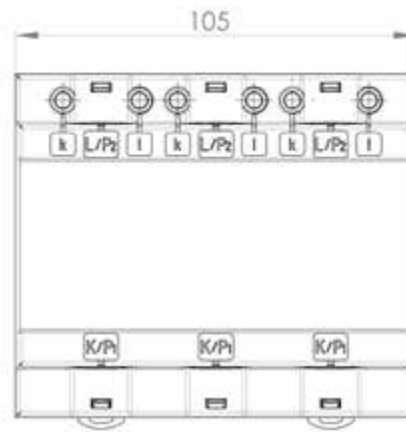
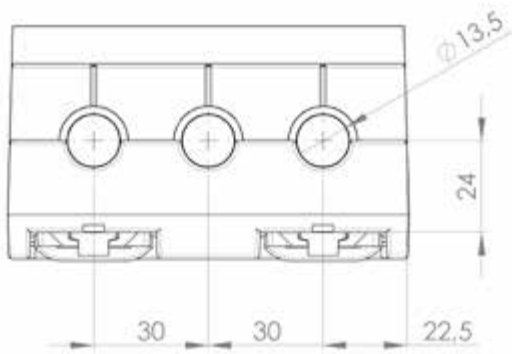
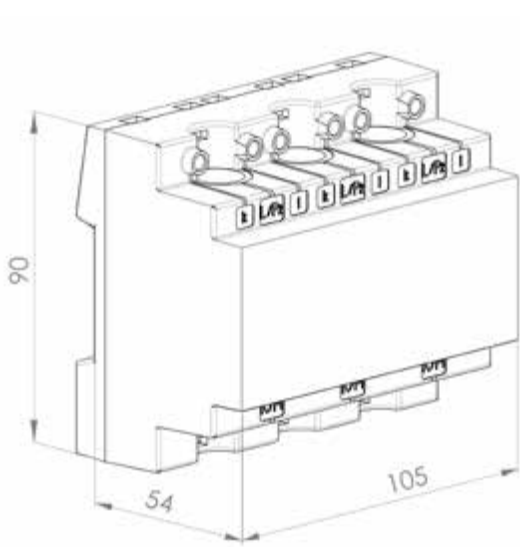

DIN RAIL CURRENT TRANSFORMERS WITH VOLTAGE TAP-OFF & BACK-UP FUSE, CLASS 0.5 & 1

DIN rail current transformers can be mounted quickly and easily and connection errors can be avoided. The integrated current transformer enables accurate current and voltage measurement.



DIN RAIL CURRENT TRANSFORMERS – TECHNICAL DATA

DIN RAIL CURRENT TRANSFORMERS

TYPE	RATIO	POWER in VA	CLASS	DIMENSIONS in mm (W x H x D)	WEIGHT in kg	PART NO.
CT 35/1A	35/1 A	0.2	1	approx. 72 x 32 x 96	0.2	1503002
CT 64/1A	64/1 A	0.2	0.5	approx. 72 x 32 x 96	0.2	1503003

DIN RAIL CURRENT TRANSFORMERS – DIMENSIONAL DRAWINGS

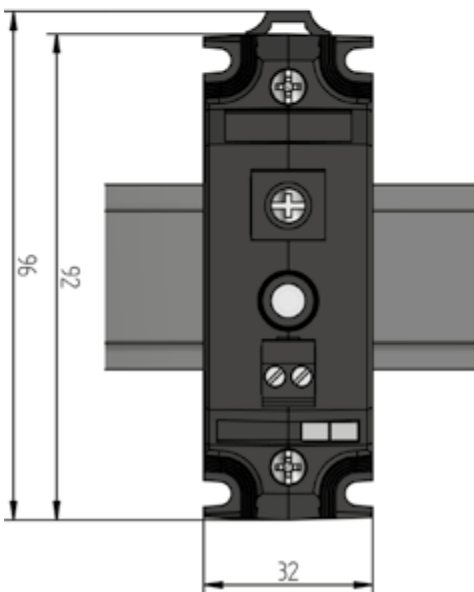
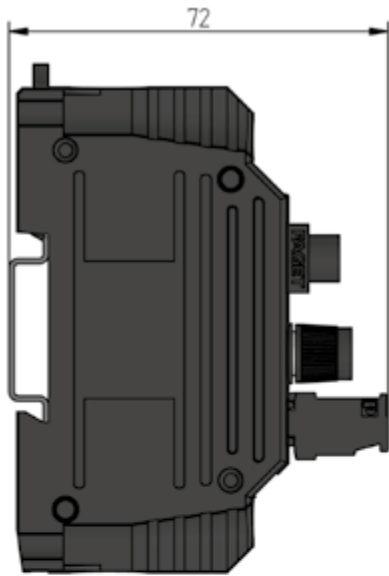

COMPACT CURRENT TRANSFORMERS TYPE CT27, CLASS 1

The CT27 compact current transformer is especially suitable for digital meters. It can be used on a 3-phase circuit breaker and complies with IEC 61869-2. It is possible to plug together several transformers of this series.



COMPACT CURRENT TRANSFORMER, TYPE CT27 – TECHNICAL DATA

COMPACT CURRENT TRANSFORMER, TYPE CT27

TYPE	PRIMARY CURRENT in A	SECONDARY CURRENT in A	POWER in VA	MAX Ø OF PRIMARY CONDUCTOR in mm	DIMENSIONS in mm (W x H x D)	WEIGHT in kg	PART NO.
CT27-35	35	1	0.2	7.5	approx. 27 x 46 x 23	0.05	1503080
CT27-64	64	1	0.2	7.5	approx. 27 x 46 x 23	0.04	1503081

ACCESSORIES

Snap-on mounting for DIN rail EN 50022-35, suitable for type CT27-35 and CT27-64	approx. 41 x 14 x 27	approx. 0.1	0909010
--	----------------------	-------------	----------------

COMPACT CURRENT TRANSFORMER, TYPE CT27 – DIMENSIONAL DRAWINGS

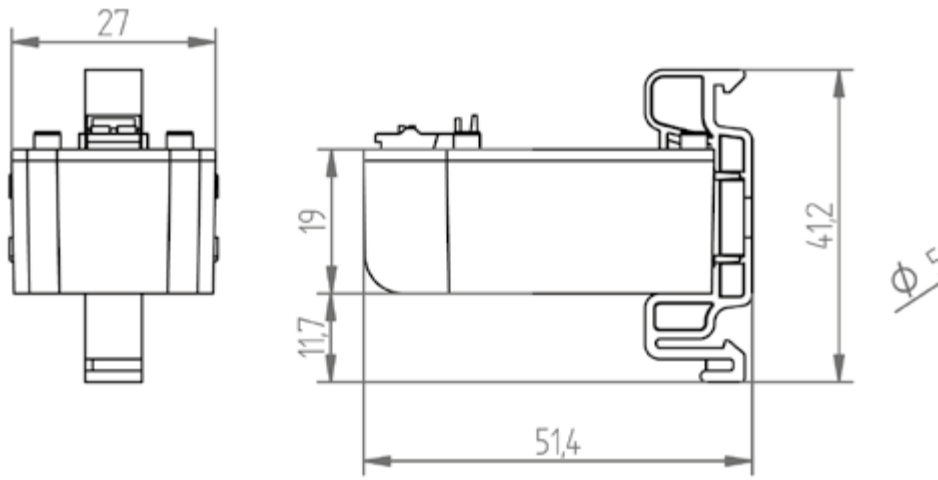

SPLIT-CORE CURRENT TRANSFORMERS FOR THE UMG 20CM, TYPE SC-CT-20, CLASS 1

Split-core current transformers are suitable for quick and safe installation in existing systems and offer transformer ratios from 3000/1 to 6000/1. They are only compatible with the UMG 20CM.



SPLIT-CORE CURRENT TRANSFORMER FOR THE UMG 20CM, TYPE SC-CT-20 – TECHNICAL DATA

SPLIT-CORE CURRENT TRANSFORMER, TYPE SC-CT-20

TYPE	MAX. OPERATING CURRENT in A	RATIO	MAX Ø OF PRIMARY CONDUCTOR in mm	CLASS	DIMENSIONS in mm (W x H x D)	WEIGHT in kg	PART NO.
SC-CT-20*	63	3000/1	10	1	approx. 32 x 41.4 x 32.3	0.04	1503092

INDIVIDUAL ACCESSORIES (LOAD IS INCLUDED IN THE SCOPE OF DELIVERY WITH THE SC-CT-20)

Load (3.9 Ω) for SC-CT-20 operating current transformers with 1.5 m connection cable and spring terminal	1503086
--	---------

* Incl. prefabricated connecting cable; 1.5 m with load and spring terminal for operating current measurement

**SPLIT-CORE CURRENT TRANSFORMER FOR THE UMG 20CM, TYPE SC-CT-20 –
DIMENSIONAL DRAWINGS**

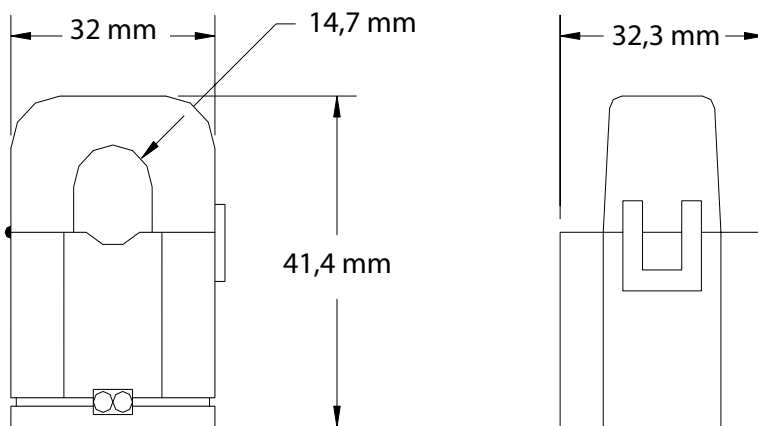

SEPARABLE OPERATING CURRENT TRANSFORMERS UP TO 600 A, CLASS 1

Thanks to their high number of secondary windings, the separable operating current transformers capture currents of up to 600 A. The snap-in split-core technology facilitates installation on existing equipment, even during operation. They are only compatible with the UMG 20CM.



SEPARABLE OPERATING CURRENT TRANSFORMERS UP TO 600 A – TECHNICAL DATA

SEPARABLE OPERATING CURRENT TRANSFORMERS UP TO 600 A

DESIGNATION	SC-CT-20-100	SC-CT-20-200	SC-CT-20-300	SC-CT-20-400	SC-CT-20-500	SC-CT-20-600
Current ratio	120 A / 40 mA	200 A / 66.6 mA	300 A / 100 mA	400 A / 100 mA	500 A / 100 mA	600 A / 100 mA
Current range (50/60 Hz)	0.01 ... 100 A (RL = 10 Ω)	0.01 ... 200 A (RL = 10 Ω)	0.1 ... 300 A (RL = 10 Ω)	0.01 ... 400 A (RL = 5 Ω)	0.01 ... 500 A (RL = 5 Ω)	0.01 ... 600 A (RL = 5 Ω)
Installation location	Indoor use (any mounting orientation)					
Operating temperature	-20 ... +50 °C			-20 ... +55 °C		
Storage temperature	-30 ... +90 °C, rel. humidity < 85% (no condensation)					

SEPARABLE OPERATING CURRENT TRANSFORMERS UP TO 600 A

TYPE	OPERATING MODES	MAX. OPERATING CURRENT in A	RATIO	MAX Ø OF PRIMARY CONDUCTOR in mm	CLASS	DIMENSIONS in mm					WEIGHT in kg	PART NO.
						A	B	C	D	E		
SC-CT-20-100	Operating current measurement* ¹	100	3000/1	16	1	55.0	41.0	29.5	31.0	19.0	approx. 0.075	1503093
SC-CT-20-200	Operating current measurement* ¹	200	3000/1	24	1	74.5	52.0	45.0	34.0	22.0	approx. 0.2	1503094
SC-CT-20-300	Operating current measurement* ¹	300	3000/1	24	1	74.5	52.0	45.0	34.0	22.0	approx. 0.2	1503095
SC-CT-20-400	Operating current measurement* ¹	400	4000/1	36	0.5	91.4	57.0	57.1	40.2	21.1	approx. 0.3	1503097
SC-CT-20-500	Operating current measurement* ¹	500	5000/1	36	0.5	91.4	57.0	57.1	40.2	21.1	approx. 0.3	1503099
SC-CT-20-600	Operating current measurement* ¹	600	6000/1	36	0.5	91.4	57.0	57.1	40.2	21.1	approx. 0.3	1503101

SINGLE ACCESSORIES (LOADS ARE INCLUDED IN THE SCOPE OF DELIVERY WITH THE TRANSFORMERS)

Load (2.2 Ω) for SC-CT-20-100 operating current transformers with 1.5 m connecting cable and spring terminal	1503087
Load (1.1 Ω) for SC-CT-20-200 operating current transformers with 1.5 m connecting cable and spring terminal	1503088
Load (0.8 Ω) for SC-CT-20-300/400/500/600 operating current transformers with 1.5 m connecting cable and spring terminal	1503085

*1 Incl. prefabricated connecting cable; 1.5 m with load and spring terminal for operating current measurement

SEPARABLE OPERATING CURRENT TRANSFORMERS UP TO 600 A – DIMENSIONAL DRAWINGS

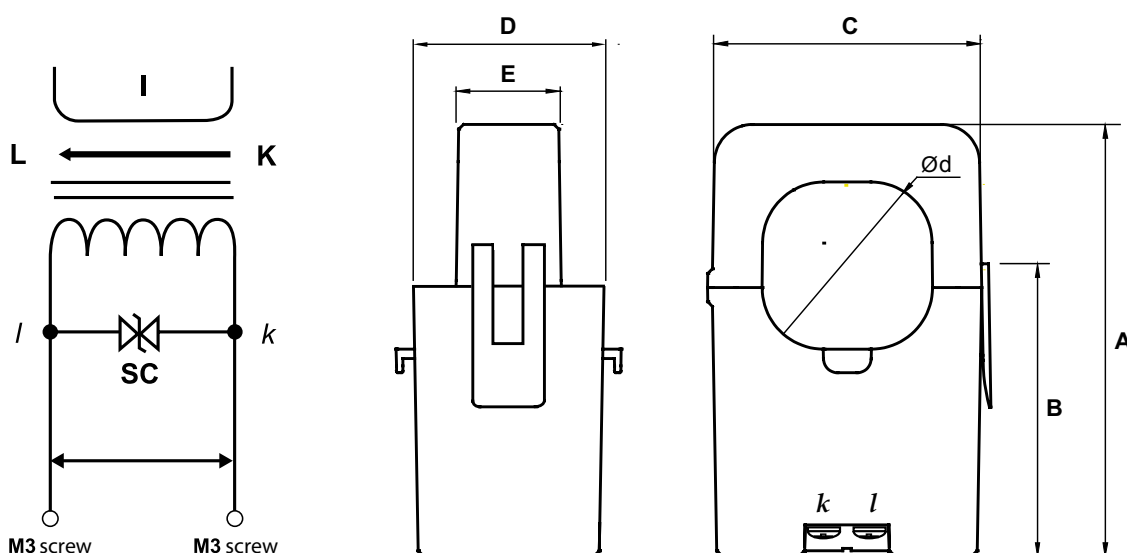

FLEXIBLE CURRENT TRANSFORMERS – ROGOWSKI COIL

The Rogowski coil is used for current measurement of AC currents and is primarily used for retrofitting in existing installations – either on busbars or on power cables.



ROGOWSKI COILS – TECHNICAL DATA

ROGOWSKI COILS				
DESIGNATION	DIAMETER in mm	LENGTH in m	WEIGHT in g	PART NO.
Rogowski current transformer, Ø 70 mm	70	3	192	15.03.609
Rogowski current transformer, Ø 175 mm	175	3	206	15.03.610
Rogowski current transformer, Ø 300 mm	300	3	222	15.03.611

Note: To ensure trouble-free operation of Rogowski current transformers always requires that a combination of the coil and the Janitza measurement transducer "RogoTrans" (part no. 15.03.613) be used! In addition, a 24 V DC power supply is required.

ROGOWSKI COILS

PART NO.	15.03.609	15.03.610	15.03.611
Max. output voltage	30 V	30 V	30 V
Primary current ^{*1}	up to 10,000 A ^{*1}	up to 10,000 A ^{*1}	up to 10,000 A ^{*1}
Ratio (@ 50 Hz)	44.44 kA/V	44.44 kA/V	44.44 kA/V
Rated frequency	50/60 Hz	50/60 Hz	50/60 Hz
Secondary voltage	22.5 mV (at 1000 A / 50 Hz)	22.5 mV (at 1000 A / 50 Hz)	22.5 mV (at 1000 A / 50 Hz)
Mutual inductance	71.98 nH	72.314 nH	72.84 nH
Temperature coefficient of M	±30 ppm/K	±30 ppm/K	±30 ppm/K
Frequency bandwidth (cable length 1.5 m) ^{*2}	420 kHz ^{*2}	350 kHz ^{*2}	300 kHz ^{*2}
Phase shift ^{*3}	0.004 ^{°*} 3	0.004 ^{°*} 3	0.004 ^{°*} 3
Coil inductance	180 µH	343 µH	566 µH
Coil resistance	56 Ω	105 Ω	170 Ω
Ratio error (centered)	0.5 ... 0.5% Class 0.5 Accuracy according to IEC 61869-2	0.5 ... 0.5% Class 0.5 Accuracy according to IEC 61869-2	0.5 ... 0.5% Class 0.5 Accuracy according to IEC 61869-2
Ratio error (all positions) ^{*4}	0.75 ... 0.75 ^{°*} 4 incl. positioning error	0.75 ... 0.75 ^{°*} 4 incl. positioning error	0.75 ... 0.75 ^{°*} 4 incl. positioning error
Linearity error	none	none	none
Influence by external currents ^{*5}	±0.2 ^{°*} 5	±0.2 ^{°*} 5	±0.2 ^{°*} 5

*1 In combination with Janitza measurement transducer RogoTrans, up to 4000 A.

*2 The model of the frequency bandwidth and the phase shift can be provided on request.

*3 When installed at right angles to the conductor.

*4 Under the condition that the Janitza Rogowski current transformer is installed perpendicular to a primary conductor of min. Ø 15 mm.

*5 Under the condition that another conductor of min. Ø 15 mm is installed at the same height and at right angles to the Janitza Rogowski current transformer.

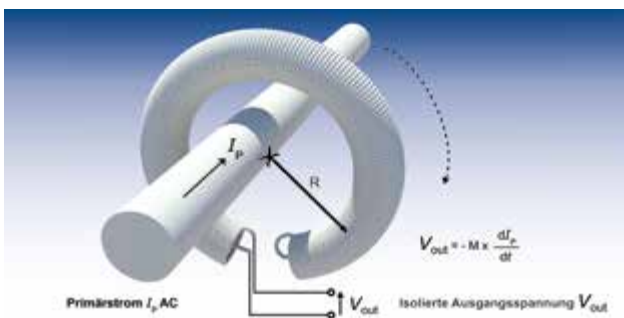

The Rogowski coil is a helical wire coil. It can be placed around an electrical conductor very easily.

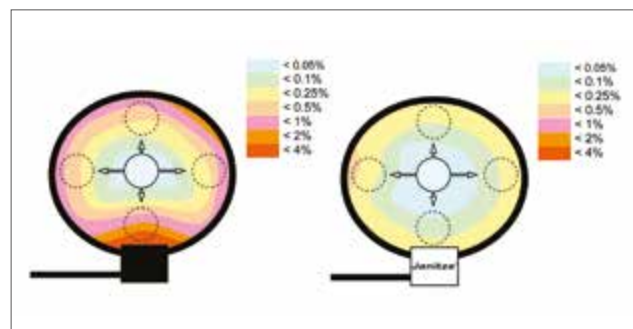

Comparison of current transformer accuracy between a conventional Rogowski current transformer and the patented Janitza solution, taking into account the mounting orientation.

FLEXIBLE CURRENT TRANSFORMERS – MEASUREMENT TRANSDUCERS

The "RogoTrans" measurement transducer for the Rogowski current transformer records alternating currents or a voltage signal and has a standardized output signal of 0...1 A.

The measuring range is up to 4000 A, the power supply is 24 V DC. The design of the measurement transducer is very compact and it can be mounted on a DIN rail.



MEASUREMENT TRANSDUCER – CONNECTION EXAMPLE

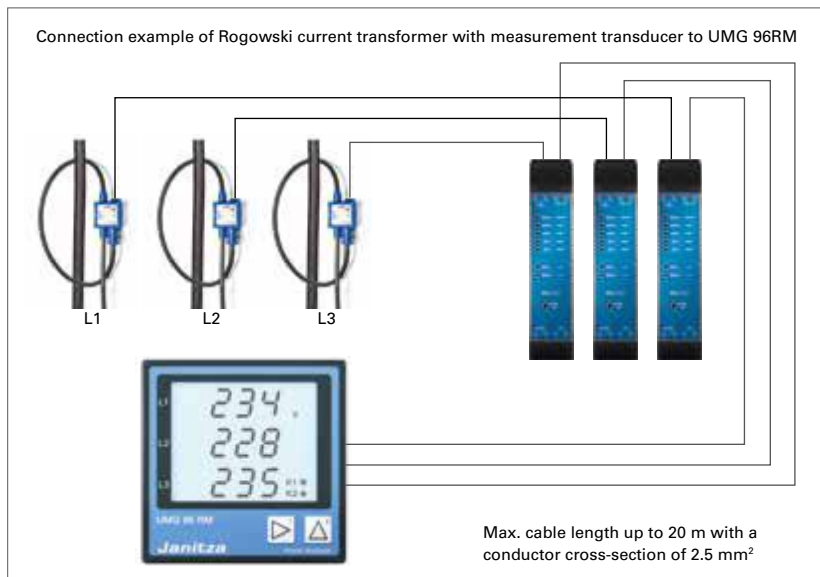

MEASUREMENT TRANSDUCER – TECHNICAL DATA

MEASUREMENT TRANSDUCER	
PART NO.	1503613
Dimensions	22.5 x 100 x 110 mm (W x H x D)
Weight	approx. 0.2 kg
Power supply	24 VDC (18 ... 36 V) / 1 A
Current draw	< 300 mA (at 1 A output current) < 80 mA (without output current)
Input	Janitza Rogowski coil max. 90 mV (4000 A range)
Current measuring ranges	1 ... 4000 A 1 ... 2000 A 1 ... 1000 A 1 ... 500 A 1 ... 250 A
Measuring range setting (button) LED (yellow)	Wear-free measuring range selection via microcontroller and PGA
Operating and measuring range display	via 6 LEDs (green)
Phase angle	< 1°
Linearity error at 50 Hz measurement error at 50 Hz	< 0.2% in all measuring ranges < 0.2% in all measuring ranges
Input impedance	10 k Ω in all measuring ranges
Signal output	0 ... 1 A
Overrange	110%
Load	0 ... 1.5 Ω
Linearity error, load 0 ... 1.5 Ω	< 0.02%
Alarm output	24 V DC / 200 mA (potential-free opto output, opens in case of error)
Alarm messages (via red LED)	Overload (out of range) Load too high (output circuit) Undervoltage (24 V)
Alarm delay	60 seconds
Protection level	IP30
Ambient temperature	-20 °C ... +70 °C
Mounting orientation	Vertical; when using several devices side by side, a minimum distance of 5 mm must be maintained between the devices (heat generation)
Storage temperature	-25 °C ... +85 °C

A combination of the coil and the measurement transducer is not compatible with the UMG 20CM.

A FLEXIBLE CURRENT TRANSFORMER – THE ROGOWSKI COIL FOR THE RCM 201-ROGO

The Rogowski coil is used for measuring AC currents and is primarily employed for retrofitting in existing installations with a choice of either on busbars or on power cables.



ROGOWSKI COIL – TECHNICAL DATA

ROGOWSKI COILS FOR THE RCM 201-ROGO

DESIGNATION	DIAMETER in mm	LENGTH in mm	WEIGHT in kg	PART NO.
Rogowski current transformer Ø 120 mm	120	375	approx. 0.16	1503622
Rogowski current transformer Ø 200 mm	200	630	approx. 0.18	1503623
Rogowski current transformer Ø 290 mm	290	910	approx. 0.20	1503624
Rogowski current transformer Ø 390 mm	390	1230	approx. 0.24	1503625
Rogowski current transformer Ø 580 mm	580	1800	approx. 0.30	1503626

ROGOWSKI COILS FOR THE RCM 201-ROGO

ENVIRONMENTAL CONDITIONS

Degree of protection	IP67 (UL recognized, UL 61010-1)
Height	Up to 2000 m (6562 ft) above sea level
Operating temperature	-30 ... +80 °C (-22 ... +176 °F)
Storage temperature	-40 ... +80 °C (-40 ... +176 °F)
Relative humidity	0 ... 95%
Installation and use	Inside

COIL

Coil length	approx. 40 ... 190 cm (15.75 ... 74.80 in) (see table on the left)
Inner diameter of the sensor	approx. 12 ... 58 cm (4.72 ... 22.83 in) (see table on the left)
Cable diameter	8.3±0.2 mm (0.33±0.008 in)
Housing material	Thermoplastic polyurethane UL94-V0
Securing	Bayonet
Weight	150 ... 500 g (0.33 ... 1.10 lb)

ELECTRICAL PROPERTIES

Rated output power	100 mV / kA @ 50 Hz (RMS values)
Max. measurable current	100 kA
Coil resistance	70 ... 900 Ω
Positioning error	Better than ±1% of measured value
Frequency	50/60 Hz
Overvoltage category	1000 V CAT III, 600 V CAT IV
Pollution degree	2
Insulation test voltage	7400 V _{RMS} / 1 min

CONNECTION CABLE

Type	3 x 22 AWG, shielded
Length	3 m (118.1 in)

COMPLIANCE WITH STANDARDS

IEC, UL standards	UL 61010-1 Ed3, UL 61010-2-032, CAN/CSA-C22.2 No. 61010-1, IEC 60529
-------------------	--

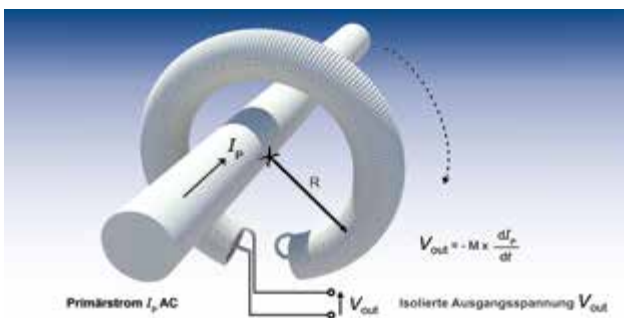

The Rogowski coil is a helical wire coil. It can be placed around an electrical conductor very easily.

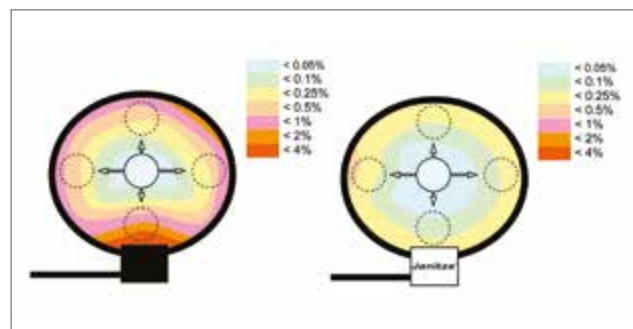

Comparison of current transformer accuracy between a conventional Rogowski current transformer and the patented Janitza solution, taking into account the mounting orientation.

THE LINK BETWEEN HEAVY CURRENT AND MEASUREMENT TECHNOLOGY

RESIDUAL CURRENT TRANSFORMERS



- 230** Separable residual current transformer
- 234** Plug-in residual current transformer, type A
- 236** Residual current transformer, type A
- 238** Residual current transformer, type B+
- 240** Compact current transformer for the UMG 20CM
- 242** Split-core current transformers
- 244** 6-fold DIN rail current transformer for the UMG 20CM

RESIDUAL CURRENT TRANSFORMER COMPATIBILITY

RCM TRANSFORMER TYPE	PART NO.	INTERIOR WINDOW	SEPARABLE YES/NO	TYPE OF RESIDUAL CURRENT	TRANSFORMER RATIO
DACT20	1503201	20 mm round	No	Type A (type B+ with RCM 202-AB)	600/1
CT-AC RCM 35N	1503458	35 mm round	No	Type A (type B+ with RCM 202-AB)	700/1
CT-AC RCM 80N	1503459	80 mm round	No	Type A (type B+ with RCM 202-AB)	700/1
CT-AC RCM 110N	1503463	110 mm round	No	Type A (type B+ with RCM 202-AB)	700/1
CT-AC RCM 140N	1503460	140 mm round	No	Type A (type B+ with RCM 202-AB)	700/1
CT-AC RCM 210N	1503464	210 mm round	No	Type A (type B+ with RCM 202-AB)	700/1
CT-20	1503082	7.5 mm round	No	Type A	700/1
SC-CT-21	1503084	8.5 mm round	Yes	Type A	700/1
CT-AC RCM A110N	1503462	110 mm round	Yes	Type A (type B+ with RCM 202-AB)	700/1
CT-AC RCM A150N	1503465	150 mm round	Yes	Type A (type B+ with RCM 202-AB)	700/1
CT-AC RCM A310N	1503461	310 mm round	Yes	Type A (type B+ with RCM 202-AB)	700/1
KBU 23D	1503400	20 mm x 30 mm rectangular	Yes	Type A (type B+ with RCM 202-AB)	600/1
KBU 58D	1503401	50 mm x 80 mm rectangular	Yes	Type A (type B+ with RCM 202-AB)	600/1
KBU 812D	1503402	80 mm x 120 mm rectangular	Yes	Type A (type B+ with RCM 202-AB)	600/1
CT-AC/DC type B+ 35 RCM	1503469	35 mm round	No	Type B+ (AC and DC)	4-20 mA (300 mA/5 A)
CT-AC/DC type B+ 70 RCM	1503468	70 mm round	No	Type B+ (AC and DC)	4-20 mA (300 mA/5 A)

PRIMARY CURRENT WITH UMG 96RM-E, UMG 509-PRO, UMG 512-PRO, UMG 96RM-PN MODULE 96-PA-RCM MODULE 96-PA-RCM-EL	PRIMARY CURRENT WITH UMG 20CM	PRIMARY CURRENT WITH RCM 202-AB	COMPATIBILITY WITH UMG 96RM-E, UMG 509-PRO, UMG 512-PRO, UMG 96RM-PN MODULE 96-PA-RCM MODULE 96-PA-RCM-EL	COMPATIBILITY RCM 202-AB	COMPATIBILITY UMG 20CM
18000 mA	1000 mA without load 16000 mA with load	20 A AC / 20 A DC	Yes	Yes	Yes
21000 mA	1000 mA without load 16000 mA with load	20 A AC / 20 A DC	Yes	Yes	Yes
21000 mA	1000 mA without load 16000 mA with load	20 A AC / 20 A DC	Yes	Yes	Yes
21000 mA	1000 mA without load 16000 mA with load	20 A AC / 20 A DC	Yes	Yes	Yes
21000 mA	1000 mA without load 16000 mA with load	20 A AC / 20 A DC	Yes	Yes	Yes
21000 mA	1000 mA without load 16000 mA with load	20 A AC / 20 A DC	Yes	Yes	Yes
21000 mA	1000 mA without load 16000 mA with load	Not compatible	Yes	Not compatible	Yes
21000 mA	1000 mA without load 16000 mA with load	Not compatible	Yes	Not compatible	Yes
21000 mA	1000 mA without load 16000 mA with load	20 A AC / 20 A DC	Yes	Yes	Yes
21000 mA	1000 mA without load 16000 mA with load	20 A AC / 20 A DC	Yes	Yes	Yes
21000 mA	1000 mA without load 16000 mA with load	20 A AC / 20 A DC	Yes	Yes	Yes
18000 mA	1000 mA without load 16000 mA with load	20 A AC / 20 A DC	Yes	Yes	Yes
18000 mA	1000 mA without load 16000 mA with load	20 A AC / 20 A DC	Yes	Yes	Yes
18000 mA	1000 mA without load 16000 mA with load	20 A AC / 20 A DC	Yes	Yes	Yes
300 mA	Not compatible	Not compatible	only UMG 96RM-E, Module 96-PA-RCM, Module 96-PA-RCM-EL	Not compatible	Not compatible
300 mA	Not compatible	Not compatible	only UMG 96RM-E, Module 96-PA-RCM, Module 96-PA-RCM-EL	Not compatible	Not compatible

SEPARABLE RESIDUAL CURRENT TRANSFORMER, TYPE KBU

Separable residual current transformers are particularly suitable for retrofitting, as they can also be installed during operation and without interrupting the primary conductor. They are available in the models type KBU and type CT-AC.



SEPARABLE RESIDUAL CURRENT TRANSFORMERS, TYPE KBU – TECHNICAL DATA

SEPARABLE RESIDUAL CURRENT TRANSFORMER, TYPE KBU											
TYPE	RATIO	MAX. PRIMARY RESIDUAL CURRENT in mA*1	MAX. WIRE DIAMETER in mm	BUSBAR RAIL in mm	DIMENSIONS in mm					WEIGHT in kg	PART NO.
					A	B	C / C1	D	E		
KBU 23D*2	600/1	18000	4 x approx. 10 (rm–10 qmm) or 8 x 7 (rm–6 qmm)	max. 20 x 30	93	106	34/58	20	30	0.7	1503400
KBU 58D*2	600/1	18000	4 x approx. 27 (rm–240 qmm) or 8 x 20 (rm–95 qmm)	max. 50 x 80	125	158	34/58	50	80	1.1	1503401
KBU 812D*2	600/1	18000	4 x approx. 42 (rm–500 qmm) or 8 x 29 (rm–240 qmm)	max. 80 x 120	155	198	34/58	85	125	1.4	1503402
ACCESSORIES											
Load (3.9 Ω) with 1.5 m connecting cable and spring terminal											1503086

*1 When using the analog inputs of the UMG 96RM-E, UMG 96RM-PN, UMG 509-PRO and UMG 512-PRO

*2 If the residual current transformers of the KBU series are used in conjunction with the UMG 20CM, the measuring range of the UMG 20CM can be increased from 900 mA or 1 A to 14 A or 15 A by connecting the load (part no. 1503086) in series.

SEPARABLE RESIDUAL CURRENT TRANSFORMERS, TYPE KBU – DIMENSIONAL DRAWINGS

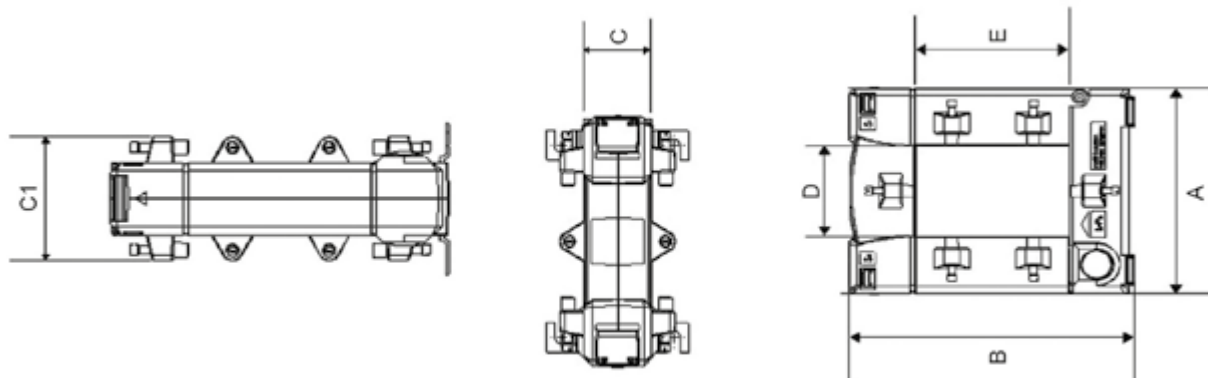

SEPARABLE RESIDUAL CURRENT TRANSFORMER, TYP CT-AC

Separable residual current transformers are particularly suitable for retrofitting, as they can also be installed during operation and without interrupting the primary conductor. They are available in the models type KBU and type CT-AC.



SEPARABLE RESIDUAL CURRENT TRANSFORMERS, TYPE CT-AC – TECHNICAL DATA

SEPARABLE RESIDUAL CURRENT TRANSFORMER, TYPE CT-AC

TYPE	RATIO	MAX. PRIMARY RESIDUAL CURRENT in mA ^{*1}	MAX. WIRE DIAMETER in mm	BUSBAR RAIL in mm	DIMENSIONS in mm			WEIGHT in kg	PART NO.
					A	B	C		
CT-AC RCM A110N	700/1	21000	4 x approx. 44 (rm-500 qmm) or 8 x 33 (rm-300 qmm)	max. 100 x 20	110	235	219	2.35	1503462
CT-AC RCM A150N	700/1	21000	4 x approx. 60 (rm-500 qmm) or 8 x 44 (rm-500 qmm)	max. 147 x 20	150	275	259	2.50	1503465
CT-AC RCM A310N	700/1	21000	4 x approx. 124 (rm-500 qmm) or 8 x 92 (rm-500 qmm)	max. 200 x 20	310	400	416	3.80	1503461

*1 When using the analog inputs of the UMG 96RM-E, UMG 96RM-PN, UMG 509-PRO and UMG 512-PRO

*2 If the residual current transformers of the CTAC series are used in conjunction with the UMG 20CM, the measuring range of the UMG 20CM can be increased from 900 mA or 1 A to 14 A or 15 A by connecting the load (part no. 1503086) in series.

SEPARABLE RESIDUAL CURRENT TRANSFORMERS, TYPE CT-AC – DIMENSIONAL DRAWINGS

CTAC RCM A310N

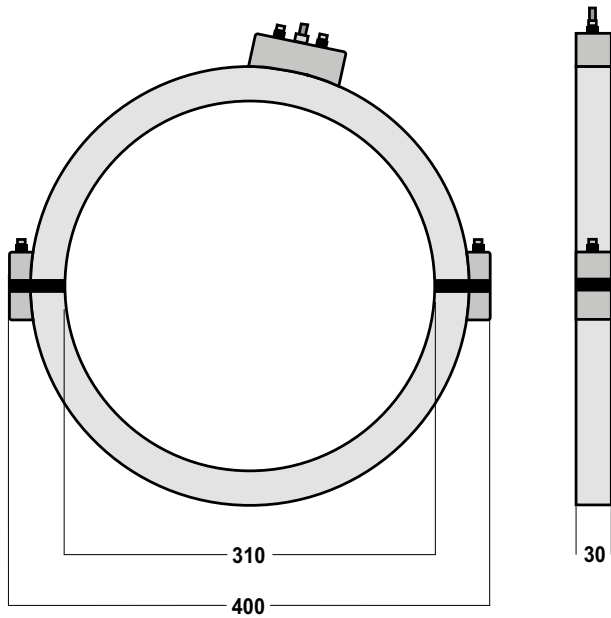

CTAC RCM A110N/150N

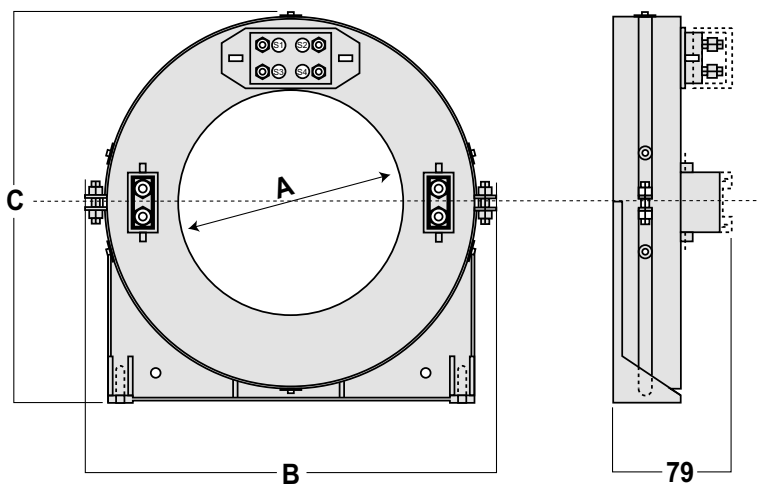

PLUG-IN RESIDUAL CURRENT TRANSFORMER, TYPE A

Plug-in residual current transformers are particularly suitable for new installations and in areas where an interruption of the primary conductor is possible. They are characterized by a very compact design and are suitable for the detection of very small currents.



PLUG-IN RESIDUAL CURRENT TRANSFORMER, TYPE A – TECHNICAL DATA

PLUG-IN RESIDUAL CURRENT TRANSFORMER, TYPE A												
TYPE	RATIO	MAX. PRIMARY RESIDUAL CURRENT in mA ^{*1}	MAX. WIRE DIAMETER in mm	BUSBAR RAIL in mm	DIMENSIONS in mm					WEIGHT in kg	PART NO.	
					A	B	C	D	E			
CT-AC RCM 35N	700/1	21000	4 x approx. 14 (rm-35 qmm) or 8 x 10 (rm-10 qmm)	max. 30 x 10	35	92	113	36	56	0.25	1503458	
CT-AC RCM 80N	700/1	21000	4 x approx. 32 (rm-300 qmm) or 8 x 24 (rm-150 qmm)	max. 60 x 20	80	125	160	36	56	0.40	1503459	
CT-AC RCM 110N	700/1	21000	4 x approx. 44 (rm-500 qmm) or 8 x 33 (rm-300 qmm)	max. 100 x 20	110	165	198	36	56	0.56	1503463	
CT-AC RCM 140N	700/1	21000	4 x approx. 56 (rm-500 qmm) or 8 x 42 (rm-300 qmm)	max. 120 x 20	140	200	234	36	56	0.75	1503460	
CT-AC RCM 210N	700/1	21000	4 x approx. 85 (rm-500 qmm) or 8 x 62 (rm-500 qmm)	max. 200 x 20	210	290	323	44	64	1.28	1503464	

*1 When using the analog inputs of the UMG 96RM-E, UMG 96RM-PN, UMG 509-PRO and UMG 512-PRO, module 96-PA-RCM-EL and module 96-PA-RCM

*2 If the residual current transformers of the CT-AC series are used in conjunction with the UMG 20CM, the measuring range of the UMG 20CM can be increased from 900 mA or 1 A to 14 A or 15 A by connecting the load (part no. 1503086) in series.

PLUG-IN RESIDUAL CURRENT TRANSFORMERS, TYPE A – DIMENSIONAL DRAWINGS

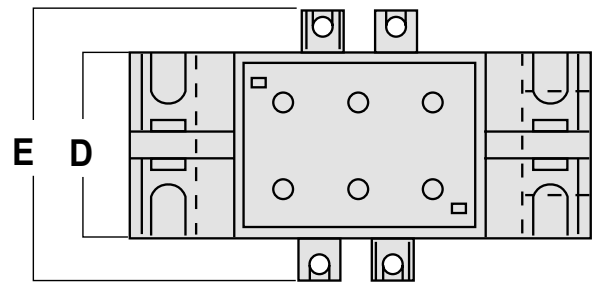
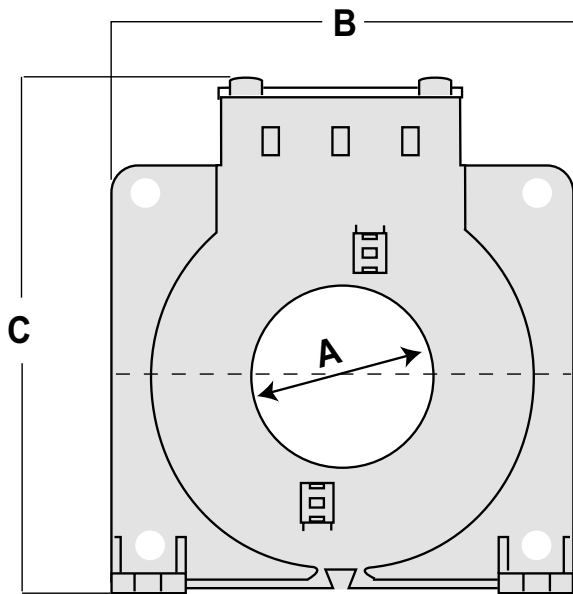

RESIDUAL CURRENT TRANSFORMER, TYPE A

The residual current transformer type A is perfectly suited for residual current detection in 3 or 4-wire AC networks. It can detect even the smallest residual currents and can be used flexibly due to its wide frequency range.



RESIDUAL CURRENT TRANSFORMER, TYPE A – TECHNICAL DATA

RESIDUAL CURRENT TRANSFORMER, TYPE A – 0.03 A SECONDARY CURRENT

TYPE	RATIO	MAX. PRIMARY RESIDUAL CURRENT in A ^{*1*2}	MAX. WIRE DIAMETER in mm	ROUND CON-DUCTOR in mm	WIDTH in mm	WEIGHT in kg	PART NO.
DACT 20	600/1	18	4 x approx. 8 (rm–10 qmm) or 8 x 5.5 (rm–6 qmm)	20	82	0.15	1503201

ACCESSORIES

Snap-on mounting	1502144
------------------	----------------

*1 When using the analog inputs of the UMG 96RM-E, UMG 96RM-PN, UMG 509-PRO, UMG 512-PRO, UMG 96-PA and UMG 96-PQ-L (in conjunction with the 96PA-RCM-EL module).

*2 If the residual current transformers of the DACT series are used in conjunction with the UMG 20CM, the measuring range of the UMG 20CM can be increased from 900 mA or 1 A to 14 A or 15 A by connecting the load (part no. 1503086) in series.

RESIDUAL CURRENT TRANSFORMER, TYPE A – DIMENSIONAL DRAWINGS

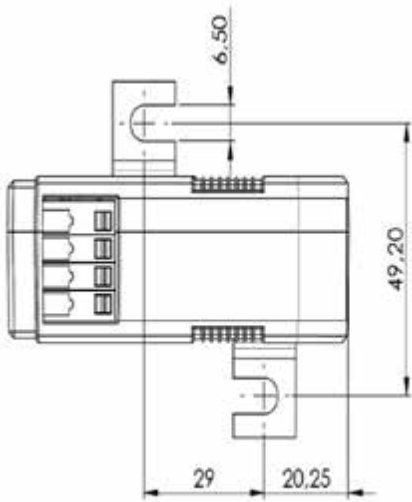

RESIDUAL CURRENT TRANSFORMER, TYPE B+

This intelligent residual current transformer monitors DC residual currents of type B+ up to 300 mA. It requires a 24 V DC supply voltage.



RESIDUAL CURRENT TRANSFORMER, TYPE B+ – TECHNICAL DATA

RESIDUAL CURRENT TRANSFORMER, TYPE B+

TYPE	OPERATING VOLT- AGE, DC	MAX. PRIMARY RESIDUAL CURRENT in mA	MAX. WIRE DIAMETER in mm	BUSBAR RAIL in mm	WEIGHT in kg	PART NO.
CT-AC/DC type B+ 35 RCM	24 V (21.6 ... 26.4 V)	300	4 x approx. 14 (rm–35 qmm) or 8 x 10 (rm–10 qmm)	max. 30 x 10	0.86	1503469
CT-AC/DC type B+ 70 RCM	24 V (21.6 ... 26.4 V)	300	4 x approx. 28 (rm–240 qmm) or 8 x 23 (rm–150 qmm)	max. 60 x 20	1.20	1503468

ACCESSORIES

Switching power supply with stepped/circuit-breaker design
prim. 85 - 264 V 50/60 Hz, sec. 24 V DC; 4.2 A
Dimensions in mm (W x H x D) 70 x 90 x 54.5; weight: approx. 270 g

1605014

TYPE	DIMENSIONS in mm							
	A	B	C	D	E	F	G	H
CT-AC/DC type B+ 35 RCM	35	99	106	69	66	87	113	104
CT-AC/DC type B+ 70 RCM	70	134	141	69	66	100	143	104

RESIDUAL CURRENT TRANSFORMER, TYPE B+ – DIMENSIONAL DRAWINGS

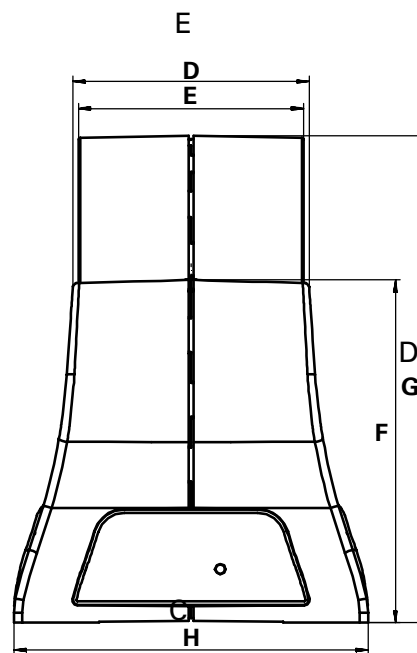
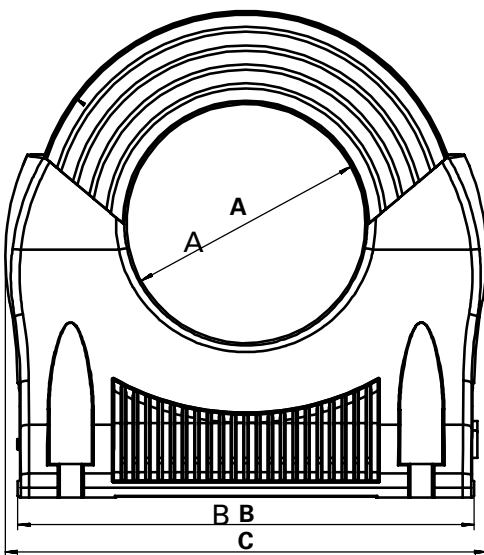
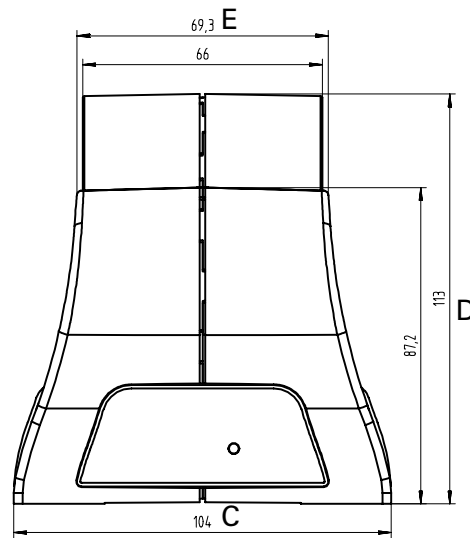
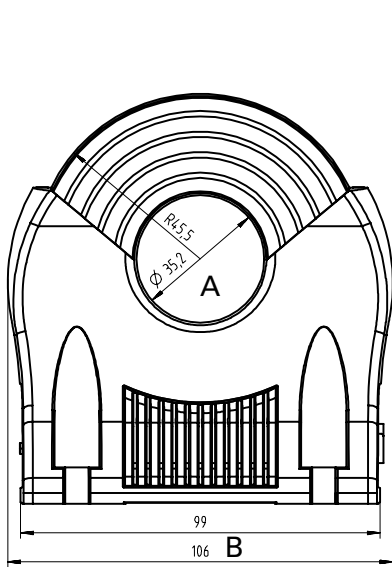

COMPACT CURRENT TRANSFORMER FOR THE UMG 20CM, TYPE CT-20, CLASS 1

This current transformer can detect both operating and residual currents. It is suitable for use in a 3-phase circuit breaker. It is possible to plug together several current transformers of this series.



COMPACT CURRENT TRANSFORMER FOR THE UMG 20CM, TYPE CT-20 – TECHNICAL DATA

CURRENT TRANSFORMER, TYPE CT-20, CLASS 1

TYPE	MAX. OPERATING CURRENT in A	RESIDUAL CURRENT in mA	RATIO	MAX Ø OF PRIMARY CONDUCTOR in mm	DIMENSIONS in mm	WEIGHT in kg	PART NO.
CT-20	63 (with load)	10 ... 1000	700/1	7.5	approx. 27 x 46 x 23	0.05	1503082
ACCESSORIES							
Snap-on mounting for DIN rail EN 50022-35, suitable for type CT-20					approx. 41 x 14 x 27	approx. 0.1	0909010
Prefabricated connecting cable: 1.5 m with load (0.8 Ω) and spring terminal for operating current measurement							1503085

COMPACT CURRENT TRANSFORMER FOR THE UMG 20CM, TYPE CT-20 –
DIMENSIONAL DRAWINGS

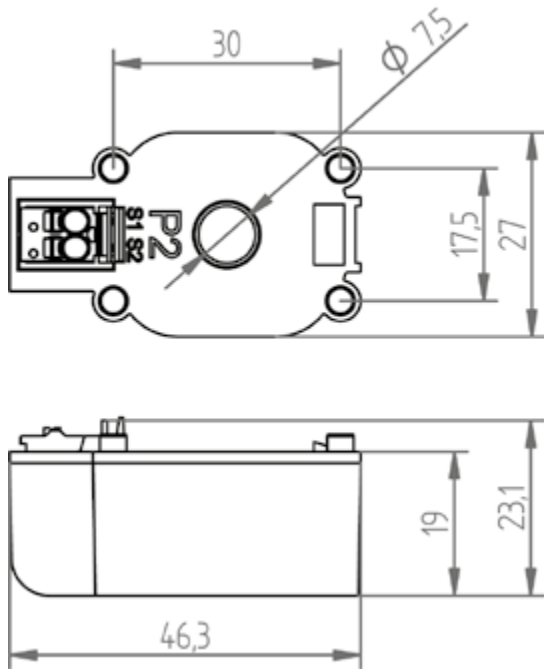

SPLIT-CORE CURRENT TRANSFORMER, TYPE SC-CT-21, CLASS 1

This current transformer can detect both operating and residual currents. It is suitable for use in a 3-phase circuit breaker. It is possible to plug together several current transformers of this series.



SPLIT-CORE CURRENT TRANSFORMER, TYPE SC-CT-21 – TECHNICAL DATA

SPLIT-CORE CURRENT TRANSFORMER, TYPE SC-CT-21, CLASS 1

TYPE	RESIDUAL CURRENT in mA	RATIO	MAX Ø OF PRIMARY CONDUCTOR in mm	ACCURACY in %	DIMENSIONS in mm	WEIGHT in kg	PART NO.
SC-CT-21	10 ... 1000	700/1	8	1	approx. 35 x 35 x 16	0.05	1503084

SPLIT-CORE CURRENT TRANSFORMER, TYPE SC-CT-21 – DIMENSIONAL DRAWINGS

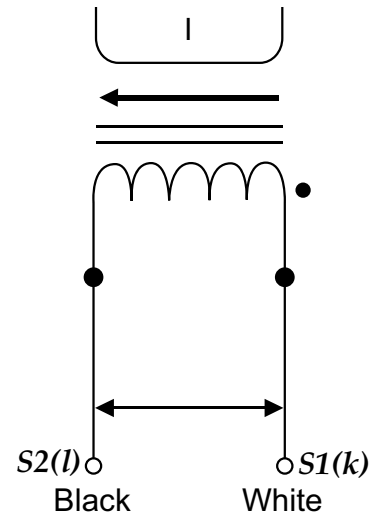
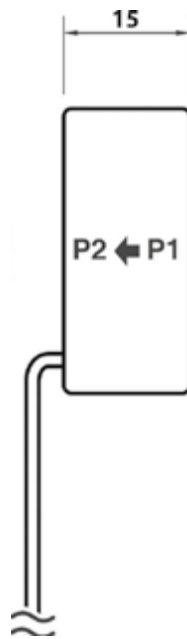
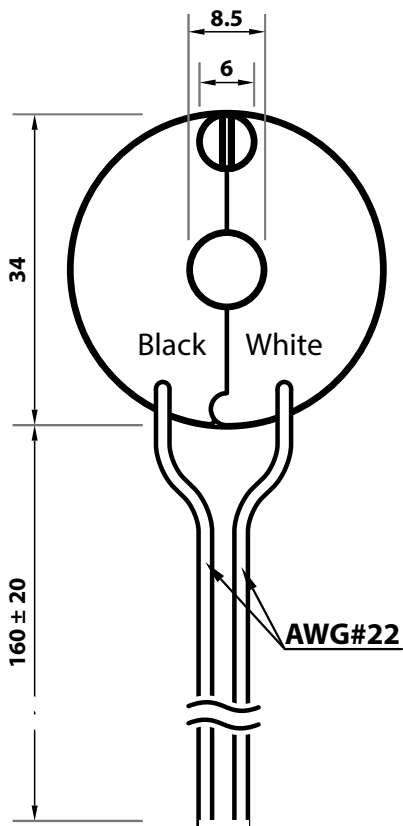

6-FOLD DIN RAIL CURRENT TRANSFORMER FOR THE UMG 20CM, TYPE CT-6-20, CLASS 1

This current transformer has been specially developed for the UMG 20CM and offers 6 measuring channels in one transformer. It enables parallel measured value acquisition and processing.

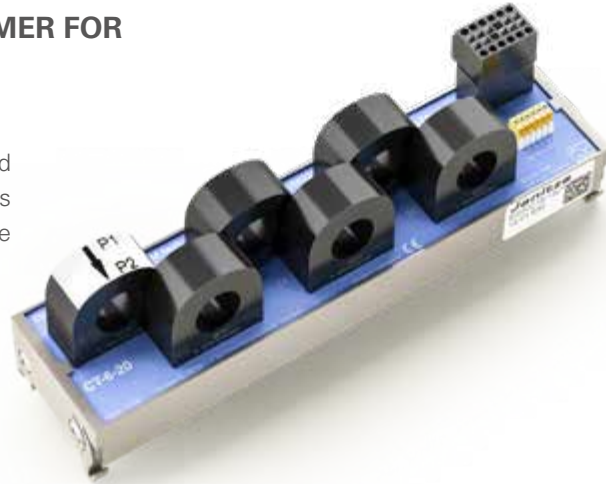

6-FOLD DIN RAIL CURRENT TRANSFORMER, TYPE CT-6-20 – TECHNICAL DATA

6-FOLD DIN RAIL CURRENT TRANSFORMERS, TYPE CT-6-20, CLASS 1

TYPE	OPERATING MODES**	OPERATING CURRENT WITH LOAD in A	RESIDUAL CURRENT in mA	NUMBER OF MEASURING CHANNELS*2	RATIO	MEASURING CURRENT ACCURACY	INSIDE DIAMETER OF TRANSFORMER in mm	DIMENSIONS in mm (W x H x D)	WEIGHT in kg	PART NO.
CT-6-20	Residual or operating currents	0 ... 63	10 ... 1000	6	700/1	1	11	174 x 45 x 56	0.30	1401630

ACCESSORIES

Prefabricated connecting cable, 1.5 m, twisted, shielded with plug

0802440

*1 Can be preconfigured as required via DIP switch

*2 transformers integrated.

6-FOLD DIN RAIL CURRENT TRANSFORMERS, TYPE CT-6-20 – DIMENSIONAL DRAWINGS

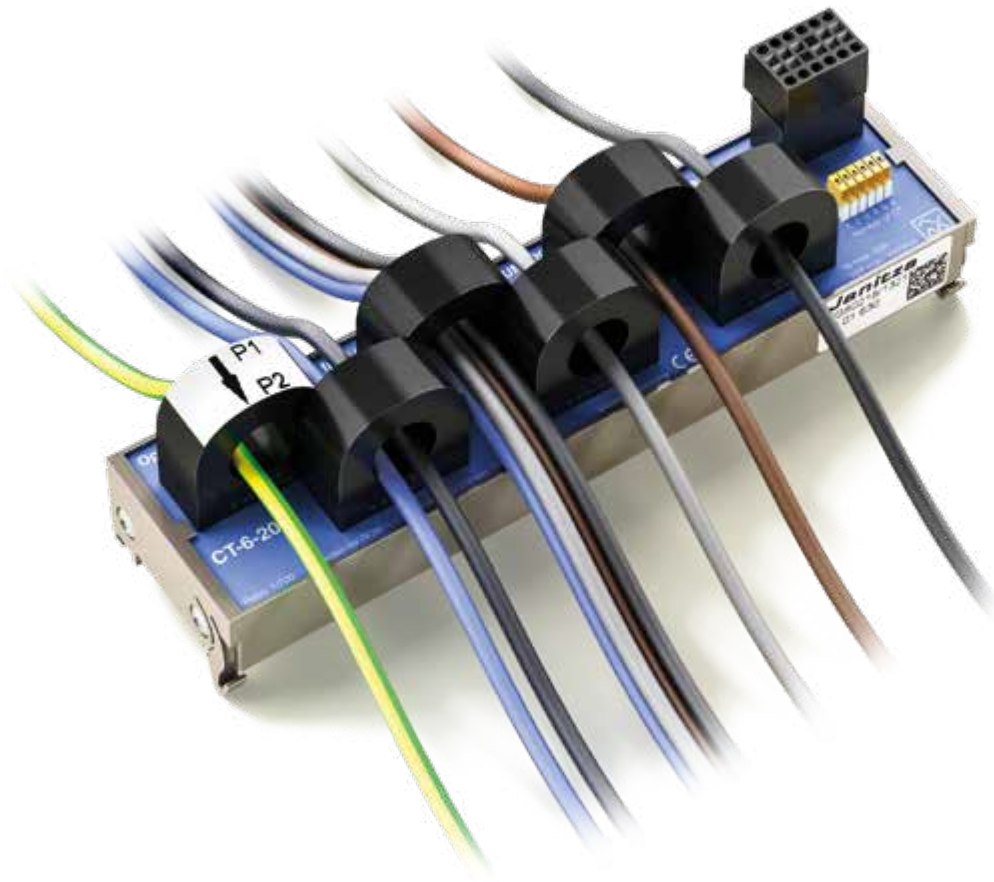
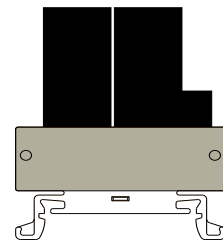
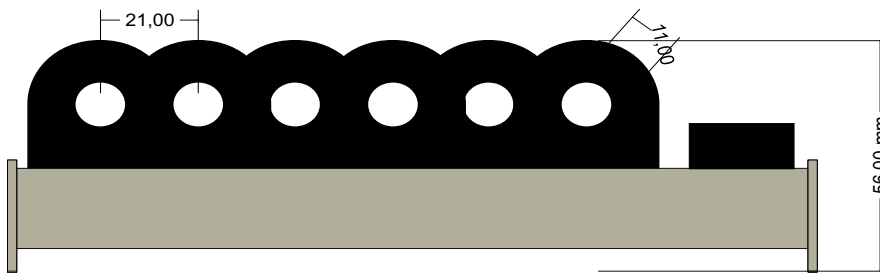
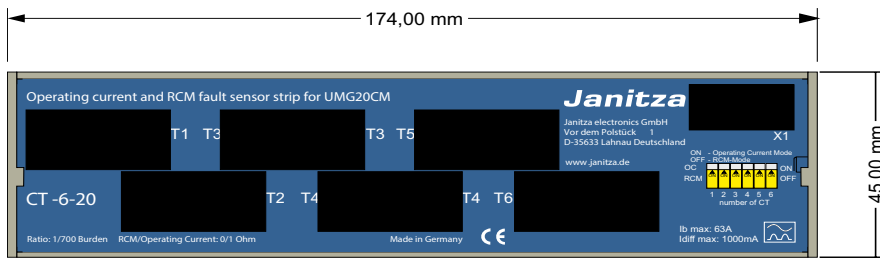

PROTECTION AND SAFETY THROUGH MOUNTING & INSTALLATION AIDS

ACCESSORIES

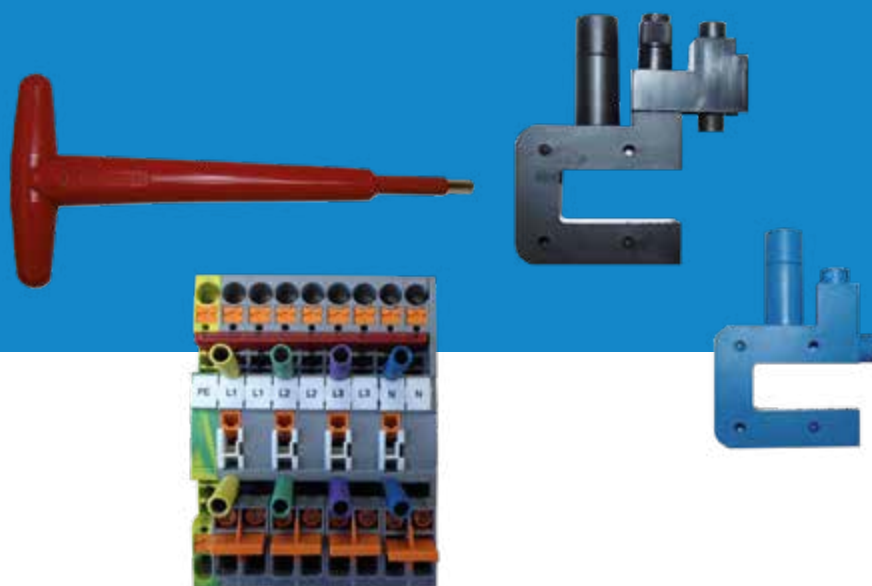

- 248** Voltage tap-offs
- 250** Current transformer terminal strip
- 251** Humidity and temperature sensor JFTF-I

VOLTAGE TAP-OFFS

- Terminals for tapping the voltage on live rails
- Suitable for tapping the voltage for energy measurement devices
- Fuse directly on the rail
- Primary connection with M8 Allen screw
- Short-circuit resistance, 70 kA at 400 V / 50 Hz
- High operational safety



VOLTAGE TAP-OFFS – TECHNICAL DATA

VOLTAGE TAP-OFFS								
TYPE	COLOR	DESCRIPTION	BACK-UP FUSE in A	CROSS SECTION, CONNECTING MEASURING CABLE, in mm ²	DIMENSIONS in mm		WEIGHT in kg	PART NO.
					A	B		
ZK4S	Black	With fuse	6.3	1.5 – 4	71	78	0.2	1011525
ZK4B	Blue	Without fuse	–	0 – 16	58.2	76	0.1	1011526
ACCESSORIES								
1 set of voltage tap-offs	3 pieces ZK4S (part no. 1011525); 1 piece ZK4B (part no. 1011526)						0.7	1011527
ZK4R	Insulated tool for securing the tap-off; 1,000 V, EN / IEC 60900						0.9	1011528

VOLTAGE TAP-OFFS – DIMENSIONAL DRAWINGS

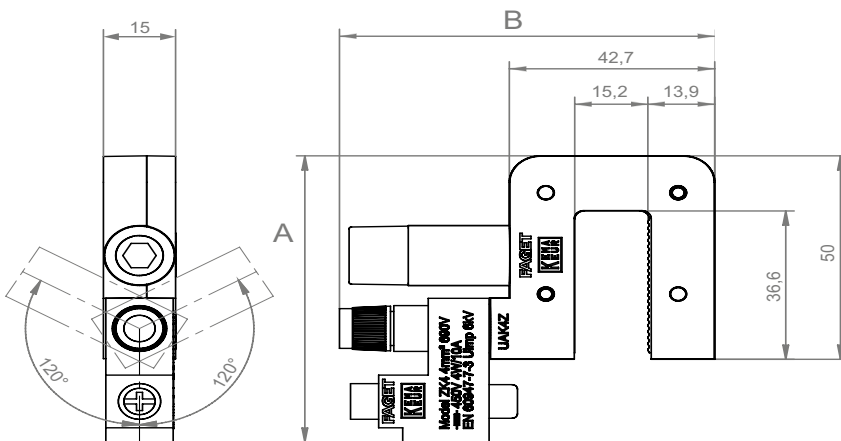

VOLTAGE TAP-OFFS

- Fused voltage tap-off for measurement purposes
- Easy mounting under existing fastening points directly on the busbar
- Compact housing
- Supplied with a 5 x 25 mm, 2 A, 450 V, F, 70 kA fuse



VOLTAGE TAP-OFFS – TECHNICAL DATA

VOLTAGE TAP-OFFS									
TYPE	COLOR	PRIMARY CONNECTION in mm	BACK-UP FUSE in A	CROSS SECTION, CONNECTING MEASURING CABLE, in mm ²	DIMENSIONS in mm		WEIGHT in kg	PART NO.	
					A	B			
ZK4/M6	Black	6	2	1.5 – 4	18.8	13.5	0.03	1011534	
ZK4/M8	Black	8	2	1.5 – 4	23.2	17	0.03	1011535	

VOLTAGE TAP-OFFS – DIMENSIONAL DRAWINGS

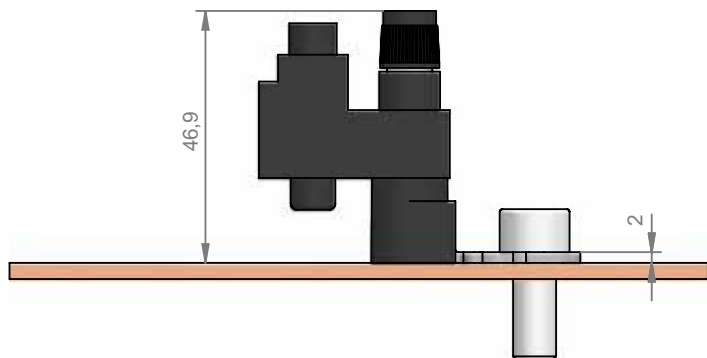
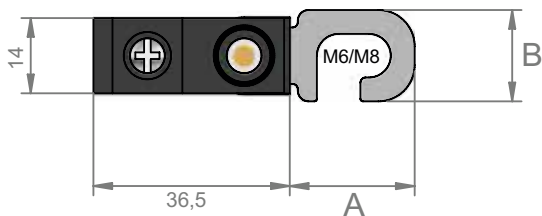

CURRENT TRANSFORMER TERMINAL STRIP

- Application: Short-circuiting of current transformers, Control measurement of energy measurement devices
- For DIN rail mounting
- Completely equipped for 4 conductors
- Consists of: Cross disconnect terminal with measuring and testing setup
- Insulated bridges for grounding and shorting of the transformer terminal



CURRENT TRANSFORMER TERMINAL STRIP – TECHNICAL DATA

CURRENT TRANSFORMER TERMINAL STRIP

TYPE	RATED CURRENT in A	RATED VOLTAGE EN VOLTAGE EN in V	RATED SURGE VOLTAGE in kV	TYPE OF CONDUCTOR	CROSS SECTION in mm ²	DIMENSIONS in mm (W x H x D)	WEIGHT in kg	PART NO.
Current transformer terminal strip	30	500	6	solid or finely stranded	0.5 – 6	86 x 108 x 65	0.30	1507001

CURRENT TRANSFORMER TERMINAL STRIP – DIMENSIONAL DRAWINGS

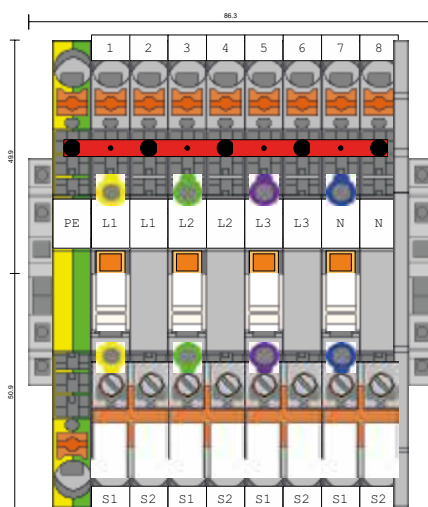

HUMIDITY AND TEMPERATURE SENSOR JFTF-I

- For measuring the relative humidity and temperature of the ambient air
- Applicable for measurement in pollutant-free, non-condensing air with no overpressure or underpressure
- High measuring accuracy
- A sintered filter protects the sensor from external contamination
- The sensors themselves are installed in a metal tube so that the self-heating of the analog unit has no falsifying influence
- Requires FBM module DI8-AI8 (part no. 1506079)



HUMIDITY AND TEMPERATURE SENSOR JFTF-I – TECHNICAL DATA

HUMIDITY AND TEMPERATURE SENSOR JFTF-I

TYPE	CURRENT OUTPUT	OPERATING VOLTAGE	RELATIVE HUMIDITY OUTPUT	TEMPERATURE OUTPUT	CURRENT RECORDING	DIMENSIONS in mm (W x H x D)	WEIGHT in kg	PART NO.
JFTF-I	2-wire technology 4 ... 20 mA	15 ... 36 VDC load-dependent	4 ... 20 mA corresponding to 0 ... 100%, Load resistance 200 ... 500 Ω	4 ... 20 mA corresponding to -20 ... +80 °C Load resistance 200 ... 500 Ω	max. 40 mA	59 x 125 x 36	0.20	1506074

HUMIDITY AND TEMPERATURE SENSOR JFTF-I – DIMENSIONAL DRAWINGS

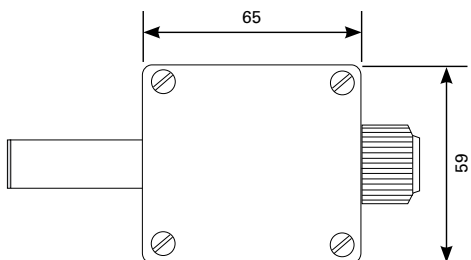
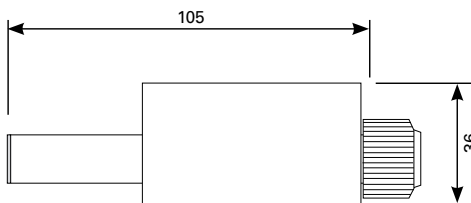

Housing dimensions may include small tolerances.

ACCESSORIES



EasyGateway V50
LTE modem



Gateway MBUS-GEM
Communication interface for the integration of supply meters



PowerToStore
Buffer power supply with capacitors



D-SUB bus connector
Plug-in connector



RS-485 repeater
RS-485 network extension



USB/RS-485 converter cable
Accessories for connecting to a PC



Switching power supply
Switching power supply for DIN rail mounting



Switching power supply
Switching power supply with circuit-breaker design



GPS radio receivers
Reception and processing of the GPS time signal (GMT)

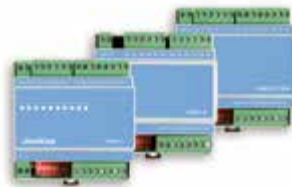

Fieldbus modules, FBM series
Decentralized I/O fieldbus modules



Accessories
Mounting and installation aids

ACCESSORIES

Accessories

254	EasyGateway V50
256	Gateway MBUS-GEM
257	PowerToStore
258	D-SUB bus connector
259	7510 – RS-485 repeater, isolated
260	K-7513 – RS-485 to 3 x RS-485 hub
261	USB/RS-485 converter cable
262	Switching power supply for DIN rail mounting
263	Switching power supply with stepped/circuit-breaker design
264	GPS radio receivers
266	Fieldbus modules, FBM series
268	Accessories – Mounting and installation aids

EASYGATEWAY V50 LTE MODEM

Data connection and easy initial commissioning

- Communication gateway for wireless and wired communication
- The EasyGateway V50 connects UMG measurement devices with an Ethernet interface to a PC via the LTE network
- The GridVis® Power Grid Monitoring Software includes a driver that enables simple establishment of a connection to the meters via the V50
- Connecting the EasyGateway to the meter
- Setting up the meter in GridVis® and selecting EasyGateway communication
- Activation of the connection via GridVis® required
- Suitable for: UMG 604-PRO, UMG 605-PRO, UMG 96RM-E, UMG 509-PRO and UMG 512-PRO
- Connection of the following devices via RS-485 (max. 10-15 devices): UMG 96-PA / UMG 96-PA-MID / UMG 96-PA-MID+ / UMG 96 PQ-L / UMG 96RM-CBM / UMG 103-CBM

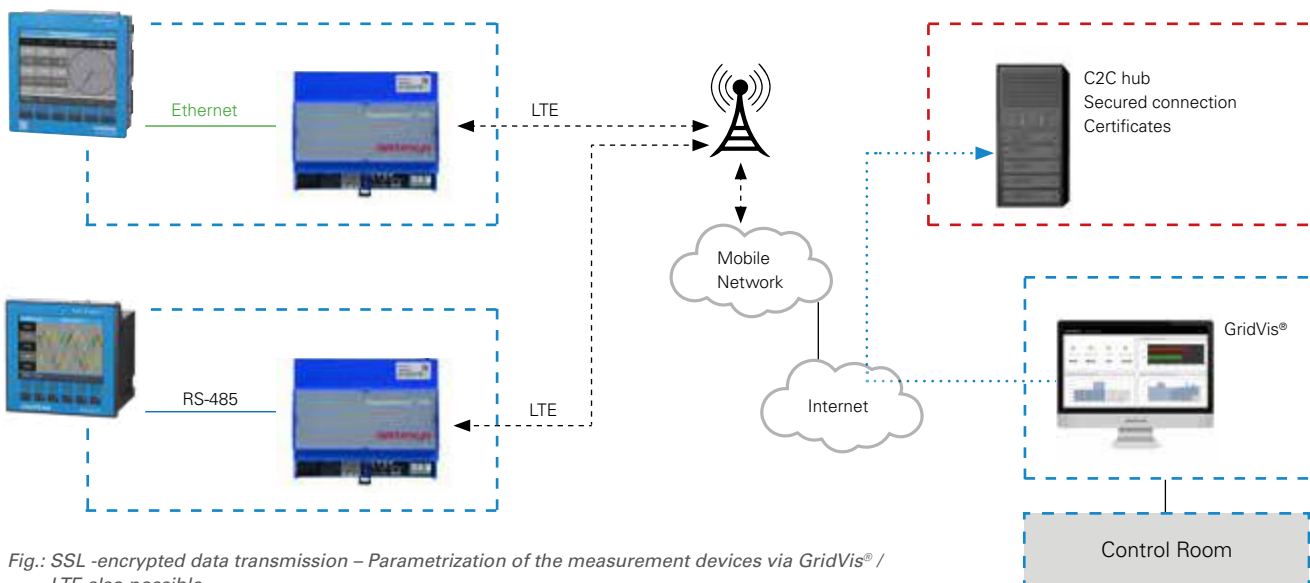

Fig.: SSL -encrypted data transmission – Parametrization of the measurement devices via GridVis® / LTE also possible

¹ The Connect-2-Control service for managing the local, static IP addresses of the Janitza UMGs as well as commissioning and administration is provided by the company aartesyS. A corresponding form for filling in is enclosed with the EasyGateway delivery or can be found at: <https://www.janitza.de/c2c-service>

Managed Service – Connect-2-Control¹

- Connect-2-Control (C2C) is a simple and secure managed solution
- It ensures easy access to the meters (location-independent) via public IP networks (Internet, mobile data networks, company networks)
- Certificate-protected security (SSL)
- SSL-encrypted from PC to gateway
- No VPN tunnel necessary
- Managing static IP addresses

EASYGATEWAY V50 LTE MODEM – TECHNICAL DATA

EASYGATEWAY V50	
EASYGATEWAY V50 LTE CAT4, LAN, RS-485	1506110
EASYGATEWAY V50 LTE CAT4, LAN	1506111
GENERAL	
Display elements	3 LEDs, bi-color red/green, for initial commissioning and operating indicator lamp 1 LED, orange, GSM status
Communication	Unrestricted Internet capability with certificate-based authentication and encryption
LAN/WAN connection	Fast Ethernet 10/100mbps, Auto-MDIX, RJ45, shielded, 2 status LEDs
Mobile communication	GPRS (quad band GPRS class 10) or HSPA+ (dual band GSM/GPRS/EDGE, dual band UMTS/HSPA) or LTE
SIM	Pluggable and/or solderable SIM (SIM multiplexer)
Local IP interface	Fast Ethernet 10/100mbps, Auto-MDIX, RJ45, shielded, 2 status LEDs
Local serial interfaces	RS-485, RS-422 and RS-232 via USB adapter
Power supply	85 to 264 V AC, optionally 18 to 75 V DC or 9 to 27 V DC
Housing	85 to 264 V AC, optionally 18 to 75 V DC or 9 to 27 V DC
Environment	Temperature range -20 °C - +70 °C, relative humidity max. 95%
Dimensions (W x H x D)	107.5 x 90 x 62 mm
Weight	280 g
ACCESSORIES	
Stainless steel antenna mounting bracket	1506094
LTE antenna for outdoor mounting	1506115
Extension cable, 2 m	1506099
Extension cable, 5 m	1506091
Extension cable, 10 m	1506092

GATEWAY M-BUS-GEM

Gateway M-Bus to Modbus TCP

- Communication interface for the integration of supply meters into GridVis®
- Connection at the control level
- Standard according to IEC6115
- Supply voltage: 24 VDC ± 5%, screw terminal
- M-Bus according to EN 13757-2, screw terminal
- Ethernet. 100 MBit, RJ45 socket, shielded
- Powerful drivers for connecting up to 80 standard loads
- Very compact design (W x H x D in mm) 35 x 89 x 58
- Space requirement 2TE width for DIN rail mounting, 35 mm DIN rail
- Galvanic isolation of M-Bus and RJ45
- Suitability for use in industrial environments
- Prerequisite: GridVis® Expert & Commissioning



Commissioning by Janitza is recommended.

GATEWAY MBUS-GEM – TECHNICAL DATA

GATEWAY MBUS-GEM	
PART NUMBER	1506108
GENERAL	
Architecture	Controller-based gateway
Supply	24 VDC, < 300 mA, max. 2.5 mm ²
M-Bus connections	Screw terminal, max. 2.5 mm ²
Ethernet connection	100 MBit, RJ45, shielded
Dimensions	35 x 89 x 58 (W x H x D in mm)
Mounting	DIN mounting rail, 35 mm, IP40
Max. baud rate	300, 2400 or 9600 bps
Number of slaves	max. 80 standard loads
IP address	freely configurable or via DHCP
TCP port	freely configurable

POWERTOSTORE

Buffer power supply with capacitors

- Typically used to bridge momentary interruptions
 - Works as an energy storage device using integrated ultracapacitors
 - When the supply voltage is interrupted, energy from the ultracapacitors is released in a controlled manner
 - A buffer module feeds the load until complete discharge
 - The buffer time depends on the charge state of the capacitor and the discharge current
 - Can only be networked with 24 V devices
 - Maintenance free for life
 - Compactly built into a housing
 - Deep-discharge resistant, thus unlimited shelf life
- Operation at extreme temperatures possible
 - No gassing, therefore installation in hermetically sealed enclosures feasible
 - Fast availability due to short recharge time after discharge



PowerToStore – TECHNICAL DATA

PowerToStore	
PART NUMBER	1506405
INPUT	
Nominal input voltage	115 – 230 V AC
Stored energy in Ws	1000
OUTPUT	
Voltage output in buffer mode	24 VDC, constant
Nominal output current	3 A
Current limiting	1.05 ... 1.2 x Inom
Efficiency $U_a = 23.5$ V DC, $I_a = I_{nom}$	> 90%
GENERAL	
Connection type, input U_E and output U_A	2.5 mm ²
Connection type, messages I/O	1 mm ²
Protection level	IP20
Type	PTS2403
Storage temperature and ambient temperature	-40 ... +60 °C
Weight	1.2 kg
Dimensions in mm (W x H x D)	72 x 153 x 130

Note: The UMG 604-PRO / UMG 605-PRO / UMG 96RM power quality analyzers are supplied by the buffer unit (part no. 1506405) in the event of a momentary interruption of up to 225 sec. For the UMG 509-PRO / UMG 512-PRO power quality analyzers, the expansion unit (part no. 1506406) is also required. A momentary interruption duration of up to 256 sec. can be accommodated here.

D-SUB BUS CONNECTOR

- For application for the RS-485 (Modbus and Profibus) for the meters UMG 604-EP, UMG 605-PRO, UMG 96RM-P, UMG 509-PRO and UMG 512-PRO
- D-SUB connector, 9-pin
- With termination (can be switched on/off termination resistors)
- Axial version with two cable entries
- Bus system: PROFIBUS DP up to 12 MBit/s
- Termination resistor can be added via dip switch
- Pin assignment: 3, 5, 6, 8
- Screw connection terminals



D-SUB BUS CONNECTOR – TECHNICAL DATA

D-SUB BUS CONNECTOR	
SUBCON-PLUS-PROFIB/AX/SC	1310539
SUBCON-PLUS-PROFIB/SC2, ANGLED	1310543
GENERAL	
Nominal voltage	50 V
Nominal current	100 mA
Termination resistor	390 Ω – 220 Ω – 390 Ω (switch-in)
Bus system	PROFIBUS DP
Mating cycles	> 200
Connections	D-SUB plug-in connection / print connection
Number of poles	9
Connection type	Screw connection
Cable diameter max.	8.4 mm
Cable diameter min.	7.6 mm
Operating temperature range	-20 ... +75 °C
Storage/transport temperature range	-25 ... +80 °C
Weight	38.6 g
Dimensions in mm (W x H x D)	31.5 x 17 x 58.2
Housing material	ABS, metalized
Pin assignment	3, 5, 6, 8

K-7510: RS-485 REPEATER, ISOLATED

- Two- and four-wire operation, RS-485
- Galvanic isolation up to 3 kV DC
- One RS-485 input and output each for expanding an RS-485 network by an additional 32 meters and by an additional 1.2 km transmission length
- Automatic direction detection
- Automatic baud rate detection
- Isolated interface
- Can also be used as a hub or RS-485 converter
- Suitable for: UMG 103-CBM, UMG 604-PRO, UMG 605-PRO, UMG 96RM, Prophi®, ProData®
- Switching power supply Connectpower required



Image similar

K-7510: RS-485 REPEATER, ISOLATED – TECHNICAL DATA

K-7510: RS-485 REPEATER, ISOLATED	
PART NUMBER	1506024
GENERAL	
RS-485 network extension	by max. length of 1.2 km and by 32 modules
Support	up to 256 RS-485 devices
Max. number of repeaters per network	8
Isolation	up to 3,000 V DC
Power consumption	1.2 W
Interface connections	to screw terminals
Mounting	DIN rail or wall mounting
Operating temperature range	-25 ... +75 °C
Weight	157 g
Dimensions in mm (W x H x D)	72 x 121 x 25

K-7513: RS-485 TO 3 X RS-485 HUB

- 1 x RS-485 input and 3 x RS-485 output for setting up a star-shaped RS-485 network
- Galvanic isolation up to 3 kV DC
- DIN rail or wall mounting
- Suitable for: UMG 103-CBM, UMG 604-PRO, UMG 605-PRO, UMG 96RM, Prophi®, ProData®
- Switching power supply Connectpower required



K-7513: RS-485 TO 3 X RS-485 HUB – TECHNICAL DATA

K-7513: RS-485 TO 3 X RS-485 HUB	
PART NUMBER	1506035
GENERAL	
Input	1 x RS-485, two-wire (D+, D-)
Output	3 x RS-485, two-wire (D+, D-)
Transmission rate	300 to 115.2 kbps
Isolation	Up to 3000 V DC
Supply voltage	10 to 30 V DC
Power consumption	2.2 W
Connections	Removable screw terminals
Mounting	DIN rail or wall mounting
Operating temperature range	-25 ... +75 °C
Weight	157 g
Dimensions in mm (W x H x D)	72 x 121 x 33
Other	Each I/O interface has its own line driver, max. 1.2 km line length per interface

USB/RS-485 CONVERTER CABLE

- Cable length 1.8 m, extendable to up to 20 m
- FTDI chip
- -40 °C to 85 °C operating temperature range



USB/RS-485 CONVERTER CABLE – TECHNICAL DATA

USB/RS-485 CONVERTER CABLE	
PART NUMBER	1506107
GENERAL	
Cable "Yellow"	Port A of the RS-485 interface of the meter
Cable "Orange"	Connection B of the RS-485 interface of the meter
Baud rate	9600, 19200, 38400 and 115 kBaud
Stop bits	1 or 2
Parity	EVEN, NONE, ODD

SWITCHING POWER SUPPLY FOR DIN RAIL MOUNTING

- 100–240 V wide range input
- Configurable voltage output
- Compact design, width only 22.5 mm
- Simple DIN rail mounting
- Operating temperature range: –10 °C and +60 °C



SWITCHING POWER SUPPLY FOR DIN RAIL MOUNTING – TECHNICAL DATA

SWITCHING POWER SUPPLY FOR DIN RAIL MOUNTING	
PART NUMBER	1605012
INPUT	
Input frequency	50 – 60 Hz, ± 6%
Input voltage	100 – 240 V AC, –15% / +10%
OUTPUT	
Power output	30 W
Voltage output	24 VDC ... 28 VDC configurable
Output current	1.3 A at 24 V 1.1 A at 28 V
GENERAL	
Conductor connection technology	Screw connection
Mounting	DIN rail
Operating temperature range	–10° C to +70° C
Weight	140 g
Dimensions	22.5 x 75 x 91 mm (W x H x D)

SWITCHING POWER SUPPLY WITH STEPPED/CIRCUIT-BREAKER DESIGN

- Universal input 85~264 V AC (277 V AC max. operating voltage)
- Power consumption without load < 0.3 W
- Insulation class II
- DC output voltage adjustable
- Protection from: Short circuit / overload / overvoltage
- Cooling by free air circulation (operating temperature: -30 °C ... +70 °C)
- Mountable on DIN rail acc. to TS-35/7.5 or 15
- Overvoltage category III
- LED display for power-on status



SWITCHING POWER SUPPLY WITH STEPPED/CIRCUIT-BREAKER DESIGN – TECHNICAL DATA

SWITCHING POWER SUPPLY WITH STEPPED/CIRCUIT-BREAKER DESIGN	
PART NUMBER	1605014
INPUT	
Input frequency	47 – 63 Hz
Input voltage	85 – 264 V, universal input 110 – 230 V
OUTPUT	
Power output	100 W
Voltage output	24 V
Output current	4.2 A
GENERAL	
Technology	AC/DC
Mounting	DIN rail
Operating temperature range	-30° C to +70° C
Weight	270 g
Dimensions	70 x 90 x 54.5 mm (W x H x D)

GPS RADIO RECEIVERS

- For use worldwide
- Reception and processing of the GPS time signal (GMT)
- For time synchronization for the meters
UMG 604-PRO*1, UMG 605-PRO*1, UMG 96-PA,
UMG 96-PA-MID+, UMG 508*1, UMG 509-PRO*1,
UMG 511*1 and UMG 512-PRO
- 1 digital connection for the control
of up to four meters
- For wall mounting
- Small, compact design
- Easy mounting, housing can be rotated
in mounting bracket



- Control LED in housing
- Connection via 3-wire shielded cable
- 21 – 28 V / DC
- External power supply necessary

GPS RADIO RECEIVERS – DIMENSIONED DRAWING

All dimensions in mm

Top view

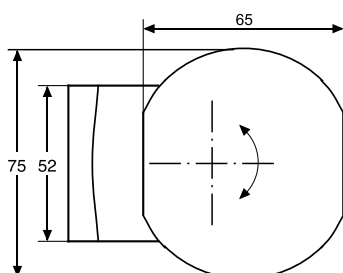

Side view

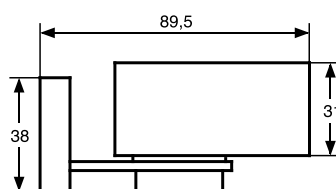

Rear view

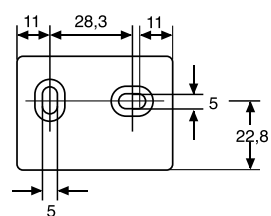

GPS RADIO RECEIVERS – CONNECTION EXAMPLE

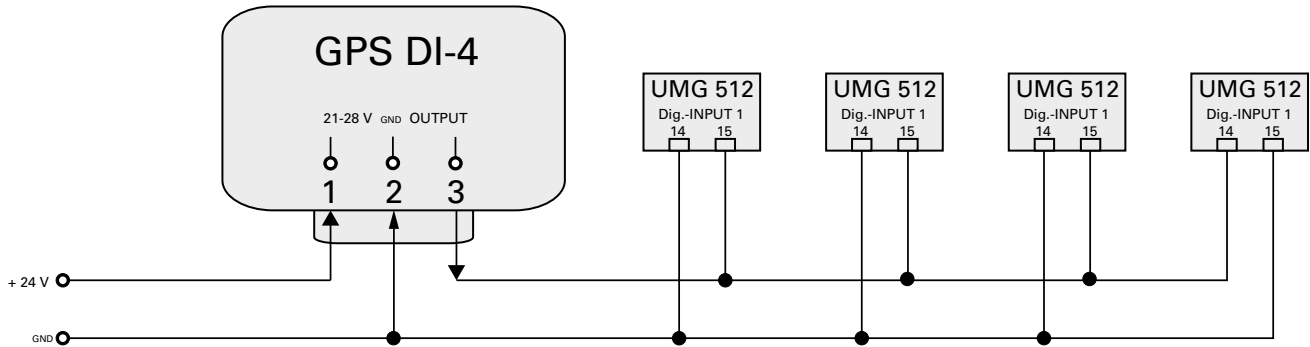

GPS RADIO RECEIVERS – TECHNICAL DATA

GPS RADIO RECEIVERS	
PART NUMBER	1506240
GENERAL	
Synchronization accuracy for the UMG 512-PRO	20 ms (relative to UTC time)
Accuracy of synchronization for the UMG 604-PRO, UMG 605-PRO, UMG 508, UMG 509-PRO and UMG 511 ^{*1}	1 s (relative to UTC time)
Supply voltage	21 – 28 V / DC Supply = external
Current draw	0 up to 100 mA
Output signal	GPS time synchronous pulse signal Configurable by DIP switch Minute (1 sec.) and/or hour pulse (5 sec.) I _{max.} 50 mA
Protection level	IP 54 according to DIN EN 60529
Ambient temperature	–30 °C ... 55 °C
Regulations / Conformity marks	EN 60730 / CE
Housing	Self-extinguishing thermoplastic
Mounting type	Wall mounting with mounting bracket
Recommended cable(s)	Shielded/cross section 0.33 to 2.5 mm ²

^{*1} Attention: For the meters UMG 604-PRO, UMG 605-PRO, UMG 508, UMG 509-PRO and UMG 511, the APP GPS TIMESYNC (21.00.291) is also required.

FIELDBUS MODULES, FBM SERIES

Decentralized I/O fieldbus modules, FBM10 series

- RS-485 interface
- Protocol Modbus RTU
- For use as a slave device to the meters of the series UMG 604-PRO, UMG 605-PRO, UMG 509-PRO and UMG 512-PRO
- Connection also possible over a distance of up to 1,000 m to the RS-485 Modbus master interface of the device; either via Profibus cable or, for example, a cable of type Li2YCY(TP) 2 x 2 x 0.22
- Modules are available ready configured and programmed according to the selected meter

Application of the FBM10I and FBM10R modules

- Merging of different input and output signals for distribution to the corresponding nodes
- To use the fieldbus modules requires a connection to the respective Modbus master of the device series UMG 604-PRO, UMG 605-PRO, UMG 509-PRO or UMG 512-PRO
- All data points integrated into the Janitza system

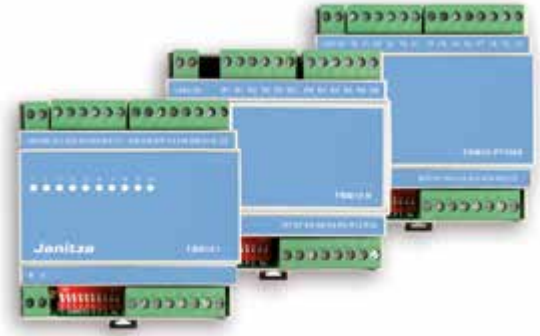

- Acquisition of a wide range of performance characteristics, such as process data, states, error messages, limit values, alarm outputs, etc.
- Archiving and visualization via the GridVis® software

Use of the FBM10PT1000 modules

- Temperature fieldbus module
- Acquisition of up to 10 temperature measurements (e.g. via PT100 or PT1000)
- The recording and visualization of the measured values is accomplished using a UMG 604-PRO, UMG 605-PRO, UMG 509-PRO or UMG 512-PRO and a required enhancement (APPs)

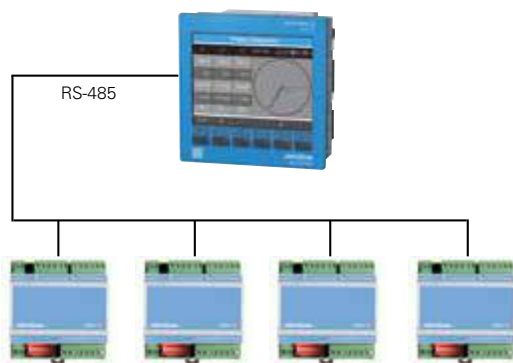

Fig.: The I/O fieldbus modules are connected via the RS-485 interface of the UMG measurement device

FBM SERIES FIELDBUS MODULES – CONNECTION EXAMPLE

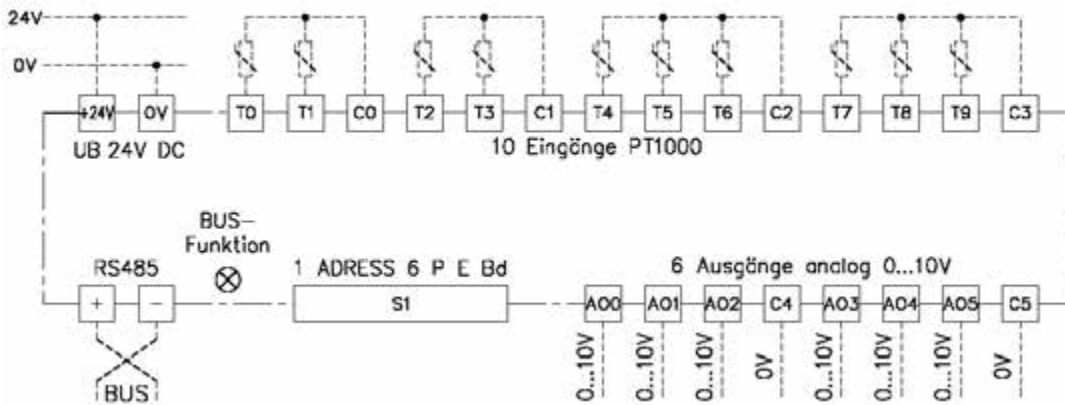

Fig.: Connection example of FBM10 PT1000/PT100; thermistor input, 2-wire

FBM SERIES FIELDBUS MODULES – TECHNICAL DATA

FIELDBUS MODULES, FBM SERIES					
TYPE	RELAY-OUTPUTS	DIGITAL INPUTS*1	ANALOG INPUTS*2	THERMISTOR INPUTS	PART NO.
FBM10I*3	-	10	-	-	1506076
FBM10PT1000*3	-	-	-	10	1506077
FBM10R-NC*3	10	-	-	-	1506078
FBM DI8-AI8*3	-	8	8	-	1506079

*1 Status message only

*2 4 – 20 mA

*3 The modules cannot be used for ProData in the gateway mode.

FIELDBUS MODULES, FBM SERIES	
Supply voltage	24 VDC ±20%
No-load current	20 mA
Interface, protocol	RS-485, Modbus RTU
Transmission rate	4,800 to 38,400 bits/s
Input digital	24 VDC, 5 mA
Relay outputs	24 VDC, 0,5 A / 230 V / 3 A AC1 / 2 A AC3
Ambient temperature	-10 ... +50°C
Accuracy	< 0.1% for PT1000 temperature measurement
EMC	according to EN 55011
Terminals	Plug-in terminals up to 1 mm ²
Housing	45 mm serial installation system, 88 x 90 x 58 mm (W x H x D)
Mounting	DIN rail
Humidity	< 95% RH non-condensing
Protection level	IP20
Standards	CE conformity

ADAPTER FOR DIN RAIL MOUNTING OF THE UMG MEASUREMENT DEVICES



ADAPTER FOR DIN RAIL MOUNTING – DIMENSIONED DRAWING

All dimensions in mm

Front view

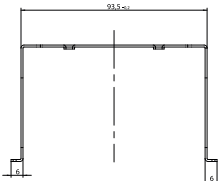

Bottom view

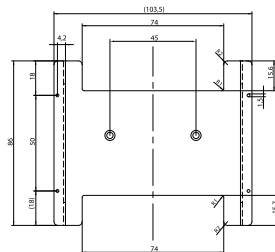

3D view

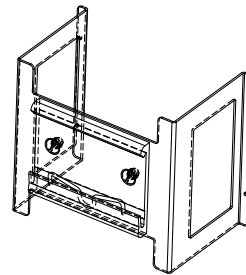

ADAPTER FOR DIN RAIL MOUNTING – TECHNICAL DATA

ADAPTER FOR DIN RAIL MOUNTING OF THE UMG MEASUREMENT DEVICES

PART NUMBER 5222666

GENERAL

Type	AH96
Dimensions	85 x 60 x 90 (W x H x D)
Suitable for	UMG 96-S2 / UMG 96RM / UMG 96RM-M

ADAPTER FOR DIN RAIL MOUNTING OF UMG WITH PROFIBUS



ADAPTER FOR DIN RAIL MOUNTING – DIMENSIONED DRAWING

All dimensions in mm

Front view

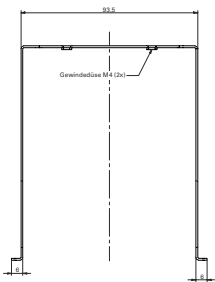

Bottom view

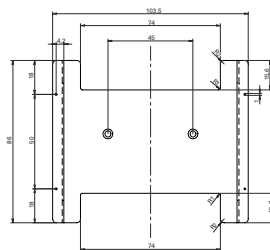

3D view

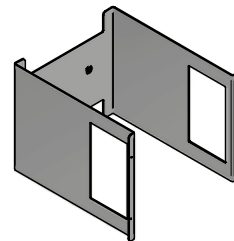

ADAPTER FOR DIN RAIL MOUNTING – TECHNICAL DATA

ADAPTER FOR DIN RAIL MOUNTING OF UMG WITH PROFIBUS

PART NUMBER 5222667

GENERAL

Type	AH96P
Dimensions	85 x 113 x 90 (W x H x D)
Suitable for	UMG 96RM-E / UMG 96RM-CBM / UMG 96RM-P / UMG 96RM-PN / UMG 96-PA / UMG 96-PQ-L

ADAPTER FOR DIN RAIL MOUNTING

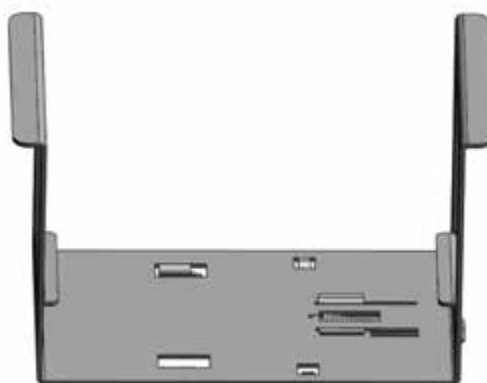

ADAPTER FOR DIN RAIL MOUNTING – DIMENSIONED DRAWING

All dimensions in mm

Front view

Bottom view

3D view

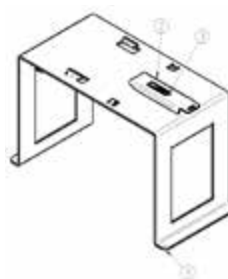
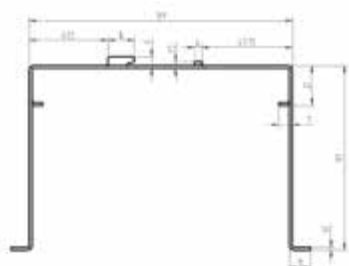

ADAPTER FOR DIN RAIL MOUNTING – TECHNICAL DATA

ADAPTER FOR DIN RAIL MOUNTING

PART NUMBER

2904154

GENERAL

Type

AH144









Dimensions

74 x 161 x 97 (W x H x D)

Suitable for

UMG 509-PRO / UMG 512-PRO

OTHER ACCESSORIES

DESIGNATION	TYPE	PART NO.	
Seal (to IP54) for UMG 96-S2, UMG 96RM, UMG 96RM-P, UMG 96RM-CBM, UMG 96RM-M, UMG 96RM-E, UMG 96RM-PN, UMG 96-PA, UMG 96-PQ-L	D96	2901065	
Seal (to IP42) for UMG 509-PRO, UMG 512-PRO and Prophi®	D144	2901903	
Blind cover in black plastic, 96 x 96 mm	BA96	2912001	
Blind cover in black plastic, 144 x 144 mm	BA144	2912002	
Adapter plate, 144 mm to 96 mm, RAL 7032	AB144/1	2912912	
Adapter plate, 144 mm to 96 mm, RAL 7035	AB144/2	2912913	
Ethernet front feed-through with mounting frame and RJ45 jack type VS-08-BU-RJ45/BU	EFD	1308016	
Protective cover, flat design, to cover the RJ45 contact insert in the mounting frame	EFDD	1308017	
Spacer for reducing the installation depth by 8.4 mm for UMG 96-PA Outer dimensions: 108 x 108 x 8.6 mm (W x H x D) Suitable for sheet thickness up to 6 mm	GEH96	2901127	



GridVis®

ANALYZE

Measurement data are worthless if not used. After collection, data must be analyzed and evaluated. This can be complicated and time-consuming, or the necessary knowledge may be lacking. With the GridVis® Power Grid Monitoring Software, data can be prepared and evaluated quickly. Predefined reports

and visualization options such as graphs simplify analysis and documentation and facilitate standard-compliant evaluation. Apps, Jasic® and other options expand the functions and evaluation options as required.

PRODUCTS

Measurement data acquisition	276	ProData® – Data logger and Ethernet Modbus Gateway
	282	JPC 100-WEB – Smart Energy Panel
Software	290	GridVis® – Power grid monitoring software
	306	GridVis® Cloud – Energy monitoring portal
	317	GridVis® Collector – Mobile data readout
	323	Multiprotocol server – OPC UA
	326	Database server – Complete server with GridVis® and database
	332	APPs – Enhancements with know-how
	344	Device homepage – Energy management & PQ analysis online
346	Jasic® – Versatile programming options	

**MEASUREMENT DATA
ACQUISITION**



ProData
Data logger and
Ethernet Modbus Gateway



JPC 100-WEB
Smart Energy Panel

MEASUREMENT DATA ACQUISITION



Measurement data acquisition

276
282

ProData® – Data logger and Ethernet Modbus Gateway
JPC 100-WEB – Smart Energy Panel

DATA LOGGER AND ETHERNET MODBUS GATEWAY

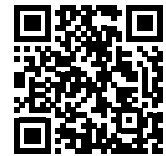

ENERGY MANAGEMENT

- Capture non-electrical values
- Limit value monitoring
- Accurate date and time information
- Energy management according to ISO 50001

PERIPHERALS

- 15 digital/pulse inputs
- 3 digital outputs
- Thermistor input

INTERFACES

- Ethernet
- RS-485

COMMUNICATION

- Modbus TCP/IP
- NTP
- Modbus RTU

MEASUREMENT DATA MEMORY

- 32 MB

ProData

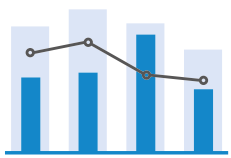
ENERGY MANAGEMENT

Energy data acquisition with pulse inputs



COMMUNICATION

Integrated Modbus gateway for integration of energy meters

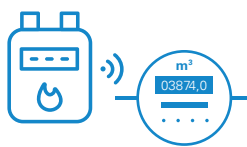

GAS & WATER

Pulse counters e.g. for Gas and water meters

ProData – DIMENSIONED DRAWING

All dimensions in mm

Front view

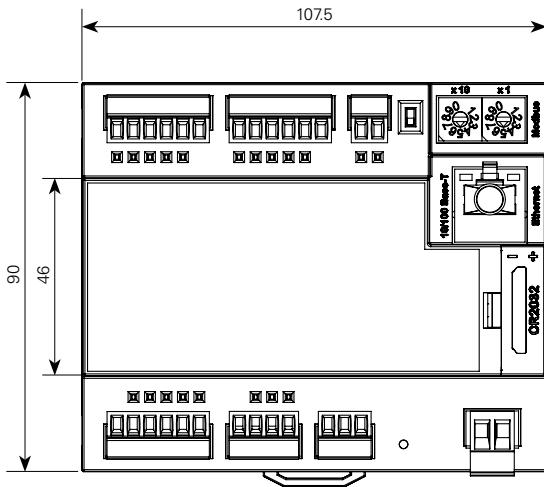

Side view

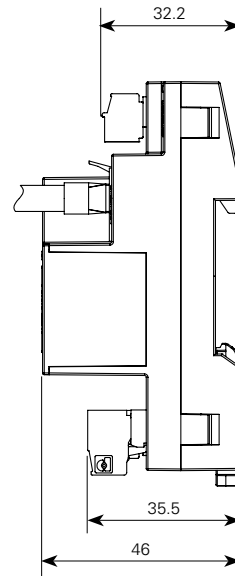

ProData – CONNECTION EXAMPLE

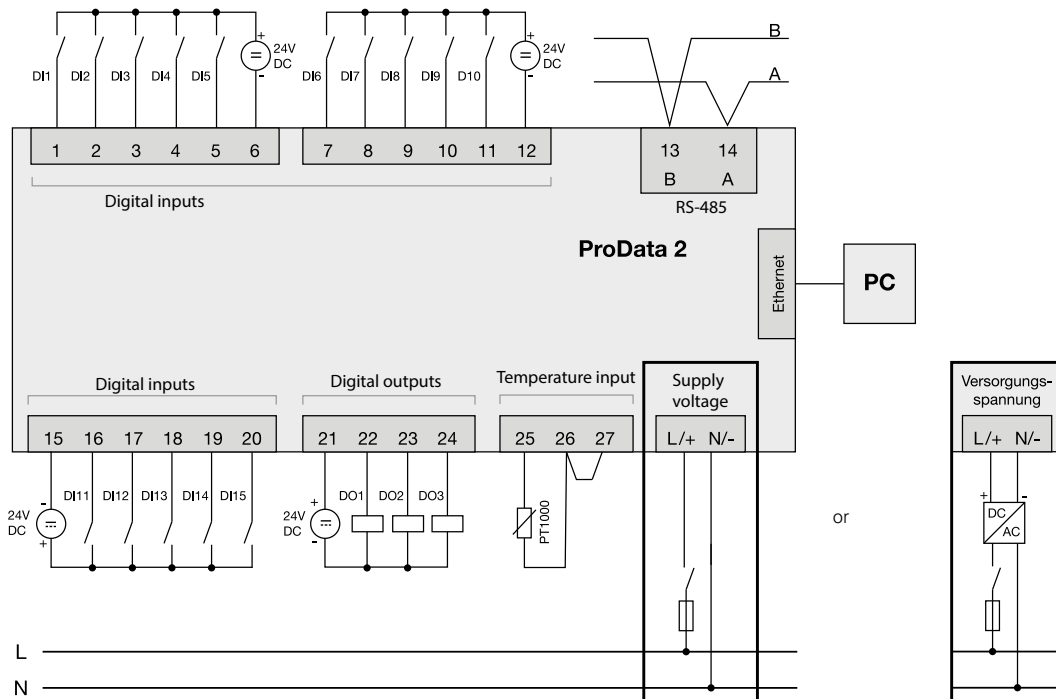

Connection example via external power supply

ProData – TECHNICAL DATA

ProData	
PART NUMBER	5224011
Supply voltage	20 – 250 V AC or 20 – 300 V DC
Installation overvoltage category	300 V CAT II
Power consumption	max. 4 VA / 2 W
GENERAL	
Use in low-voltage networks	•
OTHER MEASUREMENTS	
Operating hours meter	•
DATA LOGGING	
Memory (flash)	32 MB
Mean, minimum, maximum values	•
Alarm messages	•
Limit value monitoring	•
Time stamp	•
INPUTS / OUTPUTS	
Digital inputs	15
Digital outputs (as switching or pulse output)	3
Temperature measurement input	1
Password protection	•
COMMUNICATION	
INTERFACES	
RS-485: 9.6 – 115.2 kbps	•
Ethernet 10/100 base TX (RJ-45 socket)	•
PROTOCOLS	
Modbus RTU, Modbus TCP	•
Modbus gateway for master-slave configuration ^{*1}	•
NTP (time synchronization)	•
DHCP	•
TCP/IP	•
ICMP (ping)	•
GridVis® ESSENTIALS^{*2} SOFTWARE	
Device configuration	•
Graph function	•
Device overview	•
Event browser	•
Basic data exports	•
RCM data exports	•

• Included

^{*1} Use as a Modbus RTU slave is not possible in this mode.

The ProData can only forward queries to a Modbus slave device; it cannot query Modbus slave devices independently.

^{*2} Additional functionality can be purchased with the GridVis® Standard or Expert editions.

DIGITAL INPUTS AND OUTPUTS

Number of digital inputs	15
Operating voltage	20 - 30 V DC (SELV or PELV supply)
Pulse output (S0), maximum counting frequency	25 Hz
Input signal applied	> 18 V DC (typically 4 mA at 24 V)
Input signal not applied	0 ... 5 VDC
Number of digital outputs	3
Operating voltage	20 - 30 V DC (SELV or PELV supply)
Switching voltage	max. 60 VDC
Switching current	max. 50 mAeff DC
Pulse output (energy pulses)	max. 20 Hz
Maximum cable length	up to 30 m not shielded, from 30 m shielded
Temperature measurement input	1
Update time	1 sec.
Connectable temperature sensors	PT100, PT1000, KTY83, KTY84
Total load (sensor and cable)	max. 4 kΩ

MECHANICAL PROPERTIES

Weight	200 g
Device dimensions in mm (W x H x D)	107.5 x 90 x approx. 46
Battery	Type Lithium CR2032, 3 V, (UL 1642 approved)
Protection class according to EN 60529	IP20
Mounting according to IEC EN 60999-1 / DIN EN 50022	DIN rail
Connection capacity of the terminals (digital inputs / outputs, temperature measurement inputs)	
Solid / flexible	0.2 to 1.5 mm ²
Flexible with wire ferrules without plastic sleeves	0.2 to 1.5 mm ²
Flexible with wire ferrules with plastic sleeves	0.2 to 1.5 mm ²
Terminal connection capacity serial interface	
Single, multi-, fine-stranded	0.2 to 1.5 mm ²
terminal pins, wire ferrules	0.2 to 1.5 mm ²

ENVIRONMENTAL CONDITIONS

Temperature range	Operation: K55 (-40 ... +70 °C)
Relative humidity	Operation: 0 to 95% RH
Operating elevation	0 ... 2000 m above sea level
Pollution degree	2
Mounting orientation	As desired

ELECTROMAGNETIC COMPATIBILITY

Electromagnetic compatibility of equipment	Directive 2004/108/EC
Electrical equipment for use within certain voltage limits	Directive 2006/95/EC

DEVICE SAFETY

Safety regulations for electrical measuring, control, and laboratory devices – Part 1: General requirements	IEC/EN 61010-1
Special requirements for test and measurement circuits	IEC/EN 61010-2-030

IMMUNITY FROM INTERFERENCE

Class A: Industrial area	IEC/EN 61326-1
Electrostatic discharge	IEC/EN 61000-4-2
Electromagnetic fields, 80 - 1000 MHz	IEC/EN 61000-4-3, EMV-ILA V01-03
Electromagnetic fields, 1000 - 2700 MHz	IEC/EN 61000-4-3, EMV-ILA V01-03
Fast transients	IEC/EN 61000-4-4, EMV-ILA V01-03
Surge voltages	IEC/EN 61000-4-5, EMV-ILA V01-03
Conducted RF disturbances 0.15 - 80 MHz	IEC/EN 61000-4-6, EMV-ILA V01-03
Voltage dips, momentary interruptions, voltage fluctuations and frequency changes	IEC/EN 61000-4-11, EMV-ILA V01-03

EMITTED INTERFERENCE

Class B: Residential area	IEC/EN 61326-1
RFI field strength 30 - 1000 MHz	IEC/CISPR11/EN 55011
RFI voltage 0.15 - 30 MHz	IEC/CISPR11/EN 55011
RFI voltage 9 - 150 MHz	EMV-ILA V01-03

SAFETY

Europe	CE conformity marking
USA and Canada	UL marking



Fig.: Easy replacement of the battery during operation

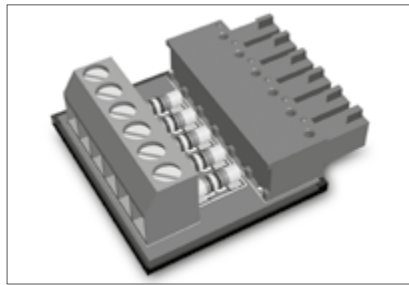

Fig.: S0 plug-in module (part no.: 52.24.111)

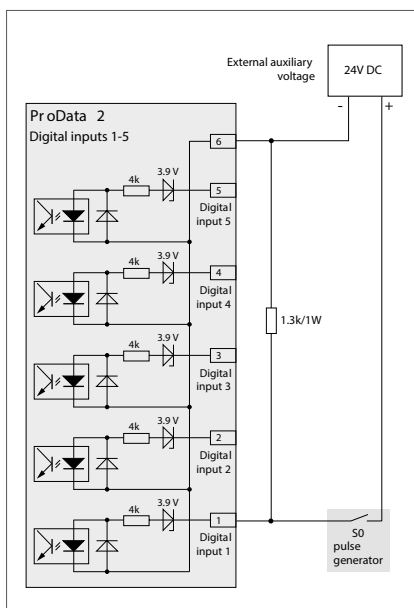

Fig.: S0 pulse output with external supply voltage and external resistor plug-in module (external resistor S0 plug-in module required for connection to S0 pulse generator, part no.: 52.24.111)

SMART ENERGY PANEL



VISUALIZATION

- Display of all current and energy measurement values
- Display and storage of the last min. and max. values
- Topology view of the connected devices
- Visualization of the main and secondary measurement

USER MANAGEMENT

- Password protected display
- Creating a hierarchical user structure
- Assignment of rights

ALARMING

- Integrated alarm management
- Acknowledgment of pending alarms
- Storage of historical alarms
- E-mail notification

DATA EXCHANGE

- Display of the device homepage
- Export of measurement data via USB
- Optional remote access

COMPATIBILITY

- Access to master and slave devices via GridVis®
- Reporting function

CONFIGURATION

- Dynamic topology configuration of up to 33 devices
- Group transfers of the configuration
- Plug & play configuration via USB: Import and export of device configurations
- Labeling of the individual measuring channels, limit values can be set per channel, etc.
- Preconfigured ex works

JPC 100-WEB

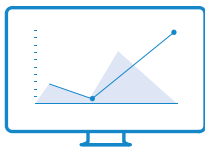

DISPLAY

Operate, configure and evaluate directly on site



COMMUNICATION

Integrate up to 33 devices



SAFETY

View limit value violations and alarms directly

JPC 100-WEB – DIMENSIONED DRAWING

All dimensions in mm

Front view

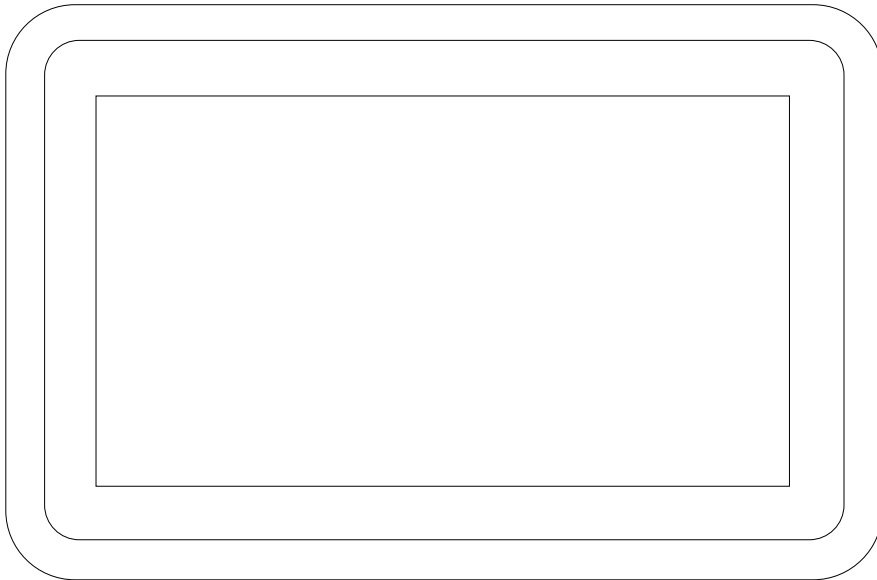

Side view

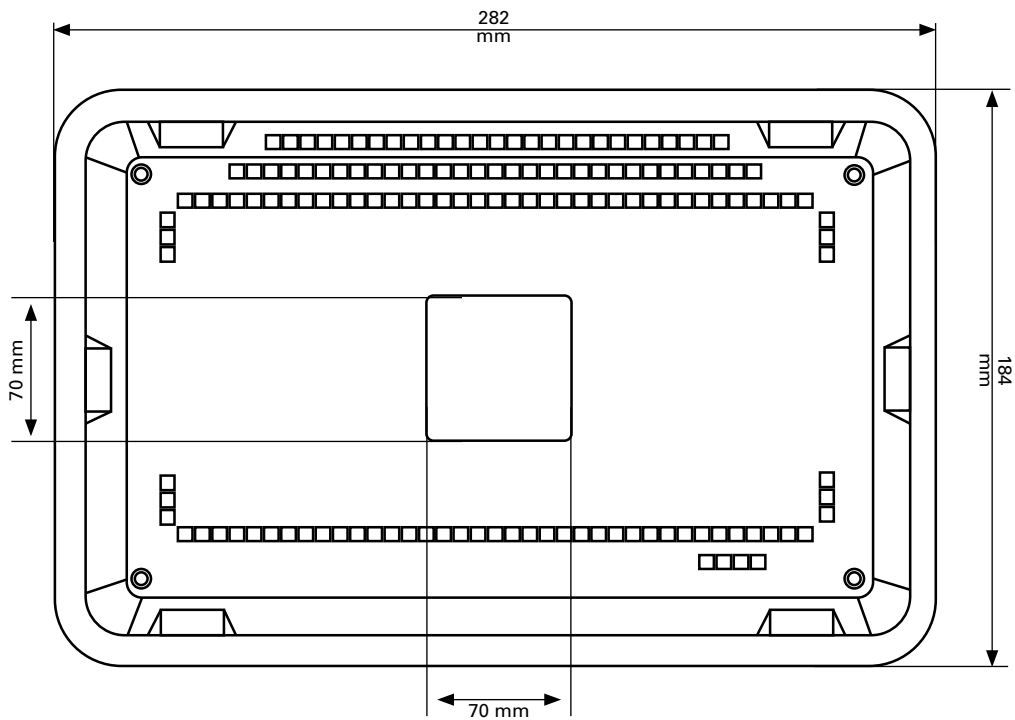
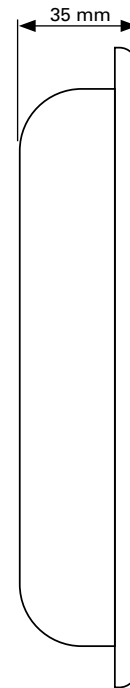

Rear view

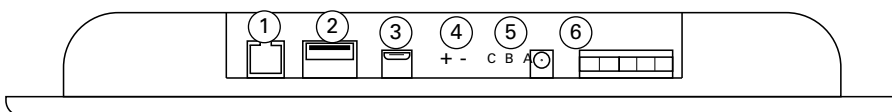

Bottom view

- | | |
|------------------|---|
| 1 Ethernet | 4 24 V supply voltage (terminal connection) |
| 2 USB 2.0 type A | 5 RS-485 (3-pole) |
| 3 Micro USB | 6 12 V supply voltage (jack connection) |

JPC 100-WEB – TECHNICAL DATA

JPC 100-WEB	
PART NUMBER	1506358**1
GENERAL	
Net weight	approx. 900 g
Dimensions	282 mm x 184 mm x 35 mm
Backlight (LED)	Brightness: typ. 450 cd/m ²
Chip	Rockchip RK3288 Quad-Core CPU 1.6 GHz
Main memory	2 GB DDR3 SDRAM
Memory capacity	8 GB eMMC
Cutout dimensions	261 ± 1 mm x 164 ± 1 mm
INTERFACES	
USB	– USB 2.0 type A – Micro USB
Ethernet	– 1x RJ45 – Transmission rate 10/100 Mbit/s
RS-485	– Protocol: Modbus RTU/master – 3-lead connection with GND, B, A – Transmission rate*2: 9.6 kbps, 19.2 kbps, 38.4 kbps, 57.6 kbps, 115.2 kbps, 230.4 kbps
DISPLAY	
Type	TFT color
Diagonal	10"
Resolution	1024 x 600 pixels
Touchscreen	Capacitive multi-touch
ELECTRICAL PROPERTIES	
Supply voltage	– 24 V DC (via terminal connection) – 12 V DC (via jack connection)
Power consumption	max. 13 W
ENVIRONMENTAL CONDITIONS	
Protection level to EN 60529	IP53 on the front, IP20 on the back
Operating temperature	0 to 35 °C
Storage and transport temperature	0 to 70 °C
Air humidity	10 to 90%, non condensing
*1 Separate switching power supply is required, optionally available: switching power supply ultraslim, 1605012 or switching power supply with step shape/DIN rail, 1605014	
*2 Ensure a uniform baud rate in the bus system.	
Configuration of communication-capable Janitza Modbus master* and slave devices**.	
* UMG 96RM-E, UMG 96-PA, UMG 604-PRO, UMG 605-PRO, UMG 509-PRO and UMG 512-PRO	
** UMG 96RM-E, UMG 96-PA, UMG 604-PRO, UMG 605-PRO, UMG 509-PRO, UMG 512-PRO, UMG 20CM, UMG 96RM, UMG 96RM-P, UMG 96RM-PN, UMG 96RM-CBM, UMG 103-CBM and meter MID B2x	

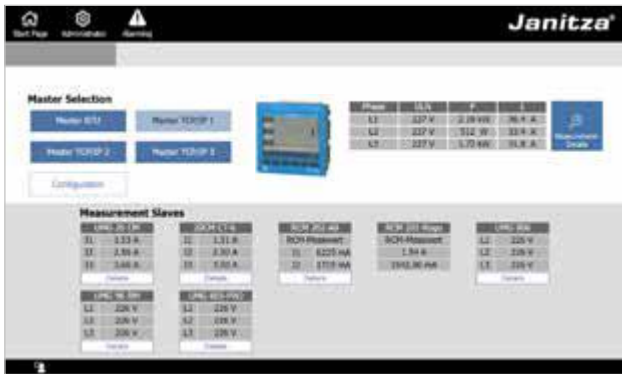

Topological view of the measured values



Configuration of all communication-capable Janitza Modbus Master and slave devices



Alarm list with acknowledgment function



User management with rights assignment



SOFTWARE



GridVis®
Power Grid Monitoring Software



GridVis® Collector
Mobile data readout



Multiprotocol server
OPC UA



Database server
Complete server with GridVis®
and database



APPs
Enhancements with know-how



Device homepage
Energy management and
power quality analysis online

Jasic®

Jasic®
Wide range of
programming options

SOFTWARE



Software

- 290** GridVis® – power grid monitoring software
- 306** GridVis® Cloud – Energy monitoring portal
- 317** GridVis® Collector – Mobile data readout
- 323** Multiprotocol server – OPC UA
- 326** Database server – Complete server with GridVis® and database
- 332** APPs – Enhancements with know-how
- 344** Device homepage – Energy management & PQ analysis online
- 346** Jasic® – Versatile programming options

POWER GRID MONITORING SOFTWARE



ENERGY MANAGEMENT

Certified according to ISO 50001. With Janitza GridVis®, you are on the safe side when it comes to things like BAFA, reduction of the EEG levy or peak balancing according to SpaEfV.

SAFETY & ALARM MANAGEMENT

Monitor limit values of measured variables, consumption data, residual currents and device communication. Escalation levels for needs-based alerting via email and web interface.

VISUALIZATION & DOCUMENTATION

Visualization according to your needs. Create dashboards quickly and easily without programming knowledge and use the report editor for custom-designed reports.

NETWORK ANALYSIS & EVALUATION

Analyze and evaluate measurement data. Use numerous tools such as statistics, charts, heatmaps, Sankey diagrams and key performance indicators.

CONNECTIVITY

Whether OPC UA, REST API or CSV. We offer many options for data import & export as well as data access. An open and future-proof system.

AUTOMATION

Automation functions for time-controlled task management. Plan data imports, report generation or device readouts and create shift schedules.

GridVis®



GridVis®
ESSENTIALS

For beginners

GridVis®
STANDARD

Advanced functions

GridVis®
EXPERT

Full range of functions

THREE APPLICATIONS – ONE SOFTWARE PROGRAM: ENERGY MANAGEMENT, POWER QUALITY, RESIDUAL CURRENT MONITORING

Implement all three application areas of energy management, power quality and residual current monitoring with the scalable GridVis® network analysis software. GridVis® identifies energy saving potentials and helps to optimize the utilization of operating equipment as well as detect production downtimes at an early stage. Numerous functions support the fulfillment of standards, the preparation of

key figures and the analysis of measured values. This makes the scalable, user-friendly software perfectly suited for developing standards-compliant energy, residual-current and power-quality monitoring systems, and it has been classified by the BAFA as energy management software that is eligible for funding. Depending on your requirements, three editions with different functionalities are available.



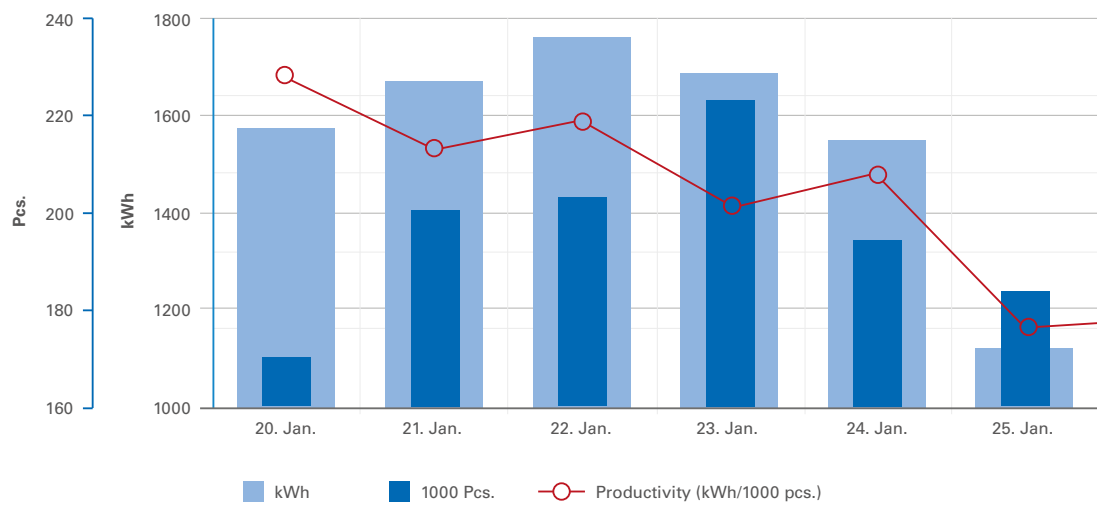

Overview of GridVis® EDITIONS

OVERVIEW

THE IDEAL RANGE OF FUNCTIONS FOR EVERY REQUIREMENT

There are three GridVis® Editions available. The free GridVis® Essentials covers basic functions for configuration, visualization and documentation. GridVis® Standard adds numerous options for visualizing data and a web interface which can be used to create dashboards, for example. Various system functions and data exports facilitate data management and enable adaptation to the respective requirements. GridVis® Expert provides the full range of GridVis® functions. A detailed overview of the functions and differences can be found in the following table.

	GridVis® ESSENTIALS	GridVis® STANDARD	GridVis® EXPERT
SYSTEM FUNCTIONS			
Device configuration	•	•	•
Service	–	•	•
Logic	–	•	•
Automation	–	•	•
Database management	–	•	•
Device monitoring	–	•	•
Online recorder	–	•	•
User management	–	•	•
Active directory	–	–	•
Alarm management	–	–	•
VISUALIZATION			
Graph function	•	•	•
Device overview	•	•	•
Event browser	•	•	•
Dashboards & templates	–	•	•
Widget basic package	–	•	•
Widget enhancement	–	–	•
Sankey diagram	–	–	•
Key performance indicators (KPI)	–	–	•
DOCUMENTATION			
Basic data exports	•	•	•
RCM data exports	•	•	•
PQ data exports	–	•	•
EnMS data exports	–	•	•
Report editor	–	–	•
CONNECTIVITY			
CSV data import	–	•	•
MSCONS data import	–	•	•
REST API	–	•	•
Modbus devices from third party suppliers	–	–	•
OPC UA Client	–	–	•
Comtrade data exports	–	–	•
MSCONS data export	–	–	•

Further information about the GridVis® Editions can be found here: <https://www.gridvis.com/us/gridvis-editions.html>



The fee-based Standard and Expert Editions can be ordered using the following part numbers

Designation	GridVis® STANDARD	GridVis® EXPERT
-------------	----------------------	--------------------

BASIC PACKAGES

Quantity of items	Part no.	Part no.
10 items	5100601	5100701
25 items	5100602	5100702
50 items	5100603	5100703
100 items	5100604	5100704
> 100 items	On request	On request

ADD ITEMS

Quantity of items	Part no.	Part no.
10 more items	5100621	5100721
25 more items	5100622	5100722
50 more items	5100623	5100723

EXTEND UPDATE PERIOD*

Quantity of items	Part no.	Part no.
10 items for 1 year	5100641	5100741
25 items for 1 year	5100642	5100742
50 items for 1 year	5100643	5100743
100 items for 1 year	5100644	5100744
> 100 items for 1 year	On request	On request

10 items for 3 years	5100661	5100761
25 items for 3 years	5100662	5100762
50 items for 3 years	5100663	5100763
100 items for 3 years	5100664	5100764
> 100 items for 3 years	On request	On request

UPGRADE TO THE EXPERT EDITION

Quantity of items	Part no.	
10 items	5100681	
25 items	5100682	
50 items	5100683	
100 items	5100684	
> 100 items	On request	

* The update period will be charged against the existing license update period and the total number of items and credited to the license.

GridVis[®] SERVICES

Benefit from individual in-house training and a versatile range of training courses at our training center in Lahnau. Professional consulting and support services are free of charge for GridVis[®] customers. We support your commissioning on site and offer fair maintenance contracts for optimal safeguarding of your system availability. Customer-specific adaptation of reports is possible.

Rely on a partner with an extensive product portfolio and many years of experience. With the cross-industry know-how of our experienced staff, we can provide you with support to integrate the perfect solution in your company.

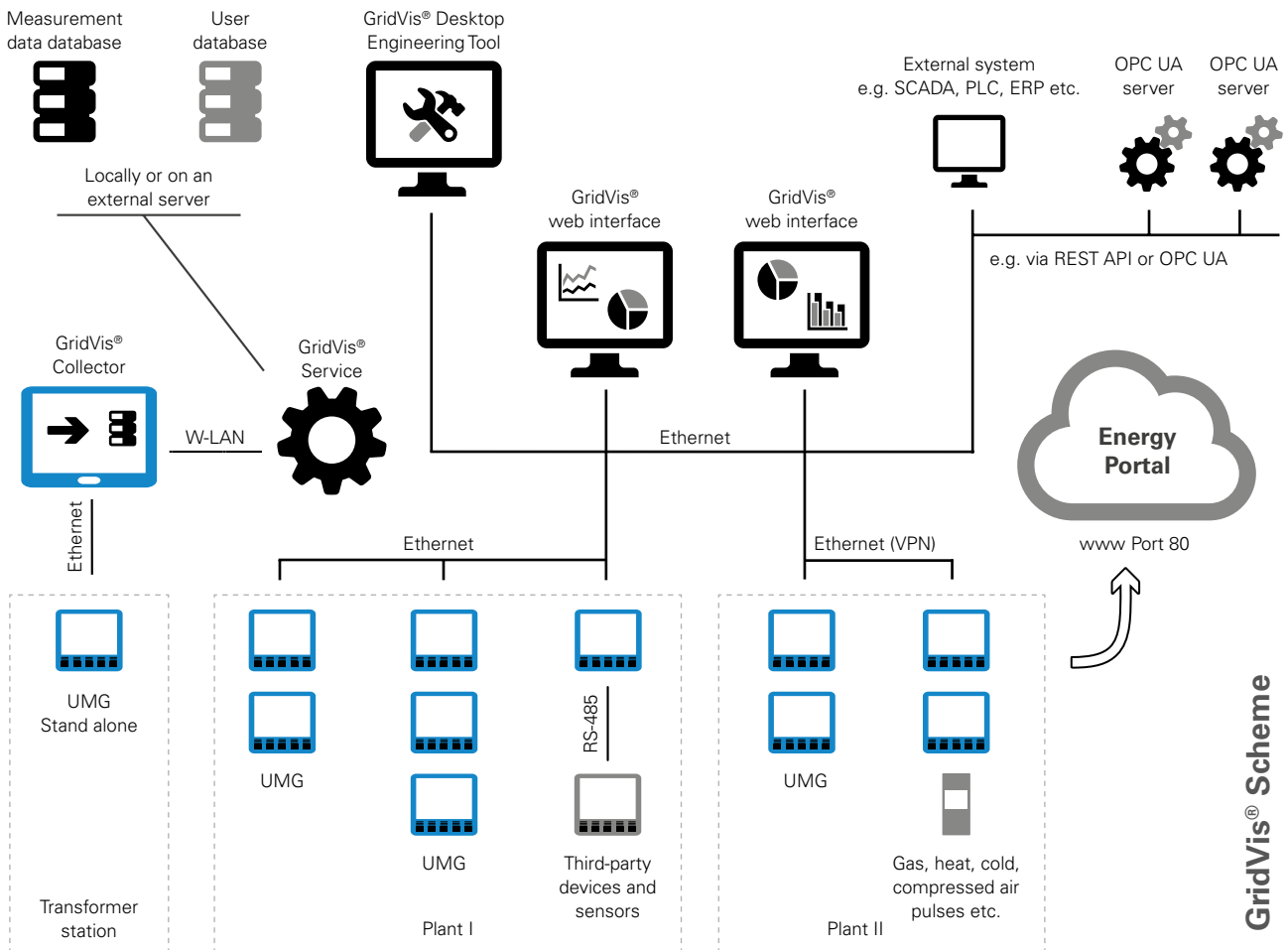

GridVis® ESSENTIALS

FREE ENTRY-LEVEL MODEL

GridVis® Essentials offers basic functions for the configuration of Janitza energy measurement devices as well as a graph function for the visualization of current and historical measured values. In addition, a tool for evaluating events and transients is included. Simple standard reports, such as the EN 50160 evaluation or CSV/XLS data exports as well as reports for residual current measurement (RCM) are provided.



Fig.: GridVis® device configuration

SYSTEM FUNCTIONS

- Configure your measurement devices using numerous setting and parametrization options.

VISUALIZATION

- Events and transients can be analyzed easily and in detail via the Event Browser using graphs, the CBEMA curve as well as statistics.
- Overview of all meters as well as a search and filter function.

DOCUMENTATION

- CSV exports and various reports, such as the commissioning report or the energy report.
- The RCM report allows clear and uncomplicated display of measurement data from residual current measurements.

GridVis® STANDARD

COMPREHENSIVE FUNCTIONALITY

In addition to the basic functions of the Essentials edition, GridVis® Standard offers numerous data visualization options and is suitable for implementing an energy management system certified according to ISO 50001. Extensive system functions facilitate the management of measurement data, create a quick overview and simplify processes. Data exports in the form of various reports facilitate evaluation. The data import function enables the import of external data such as turnover or quantities into GridVis®.

SYSTEM FUNCTIONS

- Logical links and operations to create cost centers or virtual measurement points, for example.
- Automation of functions such as data readout and tariff management, notifications in case of faulty device communication.
- Use database actions such as compressing and deleting data or backups via MSSQL/MySQL drivers.
- Manage users and their rights and roles.
- Configure your measurement devices using numerous setting and parametrization options.
- Recording of measurement data, for example for third-party devices, devices without memory or devices with an OPC UA connection.



Fig.: GridVis® device configuration



Fig.: GridVis® Event- & Transient Browser

VISUALIZATION

- Build your own dashboards with visual functions, such as line diagrams, pie charts, bar charts, and live values.
- Overview of all meters as well as a search and filter function.
- Events and transients can be analyzed easily and in detail using graphs, the CBEMA curve and statistics.

DOCUMENTATION

- CSV exports and various reports, such as the commissioning report or the energy report.
- Various data exports can be used to assess the power quality, such as the high availability report, the LET report or the EN 50160 annual evaluation.
- RCM report for clear presentation of the measurement data. For energy management, the utilization report and the energy bill are available.



Fig.: GridVis® Event- & Transient Browser

CONNECTIVITY

- Data imports from CSV or MSCONS files.
- REST API interface for developers and application engineers.

GridVis® EXPERT

FULL RANGE OF FUNCTIONS

GridVis® Expert provides the full range of GridVis® functions. This includes additional visualization options, system functions and optimal adaptation to your needs. You can create key performance indicators as well as quantity flow diagrams and combine them clearly. Your data can be imported securely and easily with the OPC UA Client. In addition, third-party devices can be integrated via Modbus/TCP or Modbus/RTU. Various protocols and interfaces are supported by the software. This means GridVis® Expert enables optimal processing of your data.



Fig.: GridVis® Dashboard example

SYSTEM FUNCTIONS

- Connection to a central Windows user management via LDAP protocol is possible.
- Monitoring of data and communication as well as alerting via different channels; logbook and escalation levels included.
- Monitoring of data and communication as well as alerting via different channels; logbook and escalation levels included.
- Logical links and operations to create cost centers or virtual measurement points, for example.
- Automation of functions such as data readout and tariff management, notifications in case of faulty device communication.
- Use database actions such as compressing and deleting data or backups via MSSQL/ MySQL drivers.
- Manage users and their rights and roles.
- Configure your measurement devices using numerous setting and parametrization options.
- Recording of measurement data, for example for third-party devices, devices without memory or devices with an OPC UA connection.



Fig.: GridVis® Report Editor

GridVis[®] EXPERT

VISUALIZATION

- Creation of flow rate diagrams. Visual representation of energy consumption based on historical values and live values.
- Visual features that can be placed on dashboards, such as line diagrams, pie charts, bar charts, and live values.
- Creation and evaluation of key performance indicators (KPI). Recognize changes and improvements in the energetic baseline (EnB).
- Overview of all meters as well as a search and filter function.
- More visual features for dashboards such as heat maps, Sankey diagrams, key performance indicators and weather.
- Events and transients can be analyzed easily and in detail using graphs, the CBEMA curve and statistics.



Fig.: GridVis[®] Report Editor

DOCUMENTATION

- CSV exports and various reports, such as the commissioning report or the energy report.
- Various data exports can be used to assess the power quality, such as the high availability report, the LET report or the EN 50160 annual evaluation.
- RCM report for clear presentation of the measurement data. For energy management, the utilization report and the energy bill are available.
- Create reports according to your own preferences, archive them within the software and download them as PDFs

CONNECTIVITY

- Integrate third-party devices via Modbus/TCP or Modbus/RTU (RS-485).
- Integration of OPC UA servers to access additional data.
- Events and transients can be stored in the Comtrade format, consumption data in the MSCONS format.
- Data imports from CSV or MSCONS files.
- Interface for developers and application engineers.

Fig.: GridVis® measured value analysis



ONLY TWO STEPS TO YOUR OWN GridVis®

1. SELECT GridVis® EDITION



In Essentials, the number of items is unlimited, so the following steps are not necessary.

2. SELECT THE BASIC PACKAGE

Basic packages are available in different sizes, depending on the number of items required. Each basic package includes an update period of one year. You can obtain the latest release at any time within the update period.

GridVis® can continue to be used after the update period has expired; updates are then no longer possible.

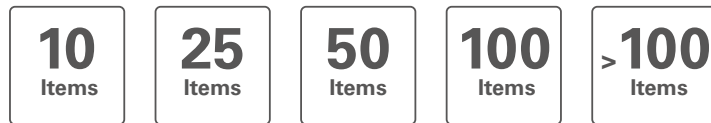

What are items?

Items are devices, users and data imports created in GridVis®.

Devices

(Measurement devices, UMG 801 modules, UMG 20 CM modules, Modbus devices from third party suppliers) *Virtual devices do not consume items and can be created in any quantities!*



Users

(created users)



Data imports

(OPC, CSV, MSCONS groups)



One meter corresponds to one item, regardless of how many data points are collected by that meter. The modules from UMG 801 and UMG 20CM are also regarded as separate items. Which does not apply to the modules of

other devices. The number of your items can be increased at any time. An item enhancement enables you to cost-effectively increase your project size.

OPTIONS, UPGRADES AND EXPANSIONS

Extend update period

(available for Standard and Expert):

If you wish to continue to receive updates after your update period has expired, you can purchase a 1 or 3 year extension of the update period at any time. You can also choose between different package sizes (see basic packages). The purchased packages are then charged and credited based on your existing items and the previous expiry date.

Not a day goes missing!

1
year

3
years

Upgrade to GridVis® Expert

(available for Standard):

With the upgrade, the range of functions of GridVis® Standard can be increased to the range of functions of GridVis® Expert. You can upgrade at any time, and the upgrade period is automatically extended by 12 months.

Please note that the upgrade also depends on the number of items. This must be greater than or equal to the currently used number of items.

Item enhancement

(available for Standard and Expert):

The basic packages can be enhanced with item packages. These enhancements can be ordered more than once and combined with each other.

10
Items

25
Items

50
Items

Calculation example – this is how the required items are calculated

GridVis®

Meters	50
Modules	10
GridVis® users	2
Data import	1
<small>One data import can contain up to 50 variables or measured values per group</small>	
<hr/> Total items	63
Item packages required	50 + 25 = 75
Items still available	12

ENERGY MONITORING PORTAL

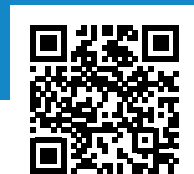

VISUALIZATION

Recognize savings potentials and weak points using data visualization

EVALUATION

Check and evaluate energy consumption and extreme values which have occurred

OVERVIEW

Interactive dashboards for a quick and comprehensive overview

COMPARISON

Compare energy consumption over time periods, locations and consumption media

SETUP

Convenient device integration and easy setup via the Cloud Connector

GridVis® Cloud

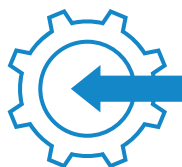
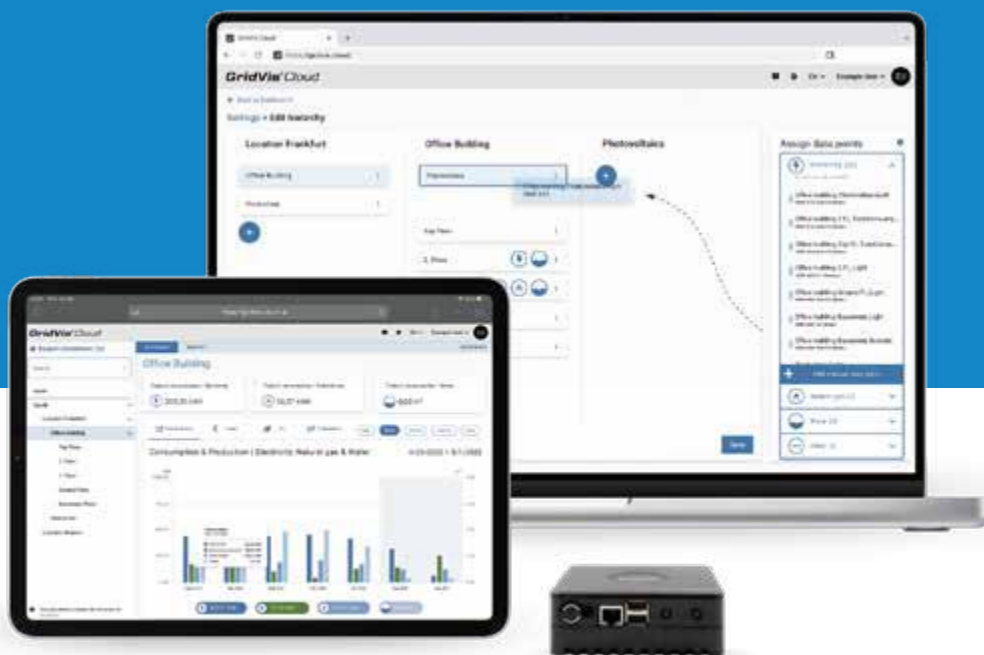

INTEGRATION

Simple and fast integration of hardware and software

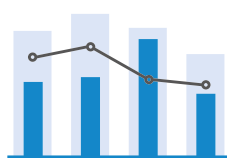

ENERGY MONITORING

Record and improve energy consumption

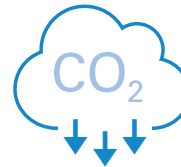

CO₂ EMISSIONS

Calculate and display CO₂ emissions and energy costs

ENERGY MONITORING PORTAL

GET STARTED QUICKLY AND EASILY

No matter whether verifications need to be provided, electricity savings are required or the CO₂ balance must be calculated, the GridVis® Cloud helps to accomplish these tasks. As a software service, it offers an energy monitoring tool that can be integrated into your daily work routine with very little effort.

Use the Cloud Connector to automatically upload measurement data to the Cloud, and then access these data anytime, anywhere on the dashboard. The start page provides a quick overview, and standardized graphical presentations and charts ensure uncomplicated evaluation. Information such as rate agreements and emissions can be integrated for subsequent automatic evaluation.



Fig.: GridVis® Cloud system architecture

OVERVIEW OF FEATURES

SYSTEM FUNCTIONS

Web-based access	<ul style="list-style-type: none">– With a standard browser on a PC/laptop– Display optimized for tablets– Access via Internet without VPN
Availability (24-hour operation)	<ul style="list-style-type: none">– Software-as-a-Service as a web application– Measurement data storage on European servers
User management	<ul style="list-style-type: none">– User management via Janitza ID
Alarm management	<ul style="list-style-type: none">– Monitoring of device communication
Supported media	<ul style="list-style-type: none">– Electricity– Gas– Water
Key performance indicators & logic	<ul style="list-style-type: none">– Measurement points (hierarchical)– Automated summation (consumption)
Automation	<ul style="list-style-type: none">– Automatic readout of energy consumption data– Time synchronization via the application (alternative for NTP)
Software-based recording of measured values	<ul style="list-style-type: none">– Online recorder for measured value recording– Janitza measurement devices without measured value memory– Third party products (Modbus TCP/RTU)

VISUALIZATION

Dashboards	<ul style="list-style-type: none">– Predefined dashboards (display filtered to one measurement point)
List function	<ul style="list-style-type: none">– Hierarchy (project structure with levels)– Device overview– Search and filter function
Energy and measured value analysis	<ul style="list-style-type: none">– Graph function on the web– Aggregation function– Comparison periods

CONNECTIVITY

Data import	<ul style="list-style-type: none">– Manual data entry
External devices	<ul style="list-style-type: none">– Integrate third-party devices via Modbus

GridVis® Cloud HIGHLIGHTS



Fig.: GridVis® Cloud – Store energy contracts

COSTS AND CO₂ EMISSIONS

- Easily store contracts and conversion factors
- Show costs incurred and CO₂ emissions
- Conversion to a uniform consumption basis (if possible)
- Automatic conversion when displaying the data
- Cost development in charts for all media

USER FRIENDLY OPERATION

- Drag & drop principle
- Automatic readout of connected measurement devices
- Central, automatically generated overview page
- Build and map structures easily
- Intuitive management of offline measurement devices
- Optimized display and operation for tablets

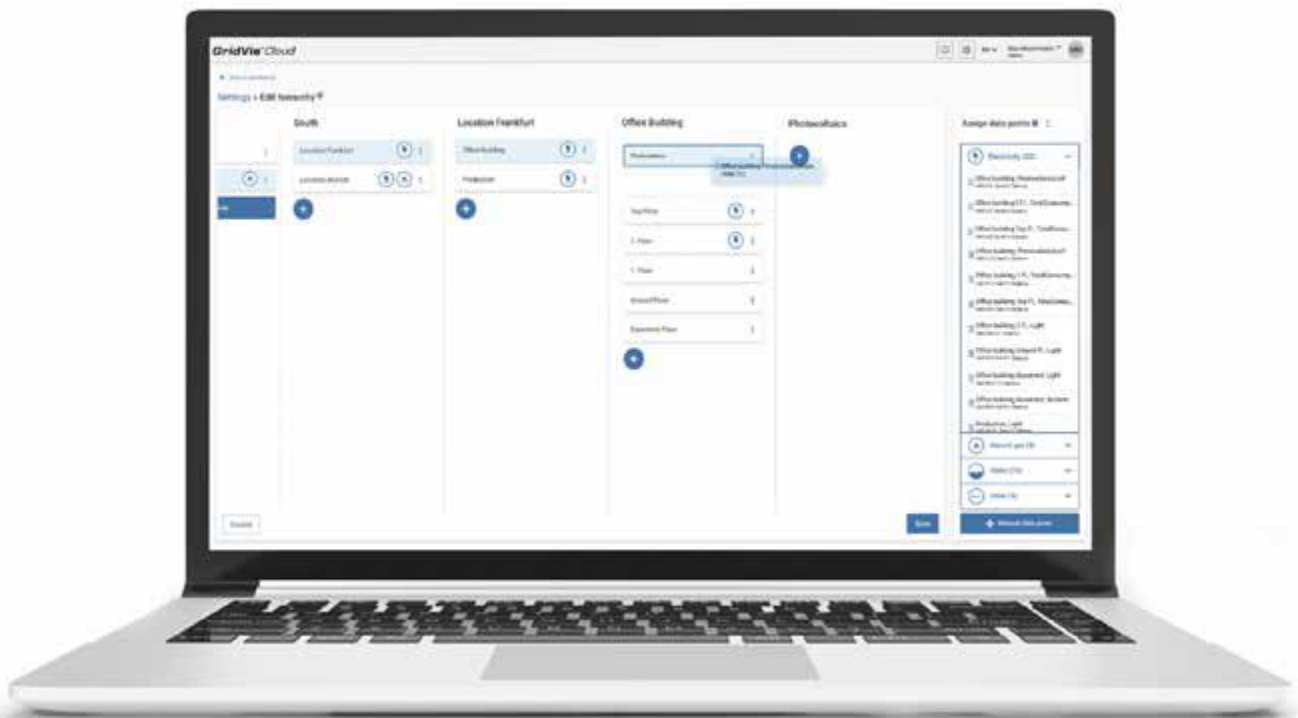

Fig.: GridVis® Cloud – Intuitive configuration of the structure

GridVis® Cloud HIGHLIGHTS

AUTOMATED PAGE AND DATA PREPARATION

- Filtered display depending on the selection of the viewing point
- Media-related display as well as the option to show and hide individual media
- Standard calculation of the sum of consumptions in subcategories
- Storage and display of the 15-minute consumption values
- Distinction between generated and consumed energy
- Presentation of generated energy in a chart

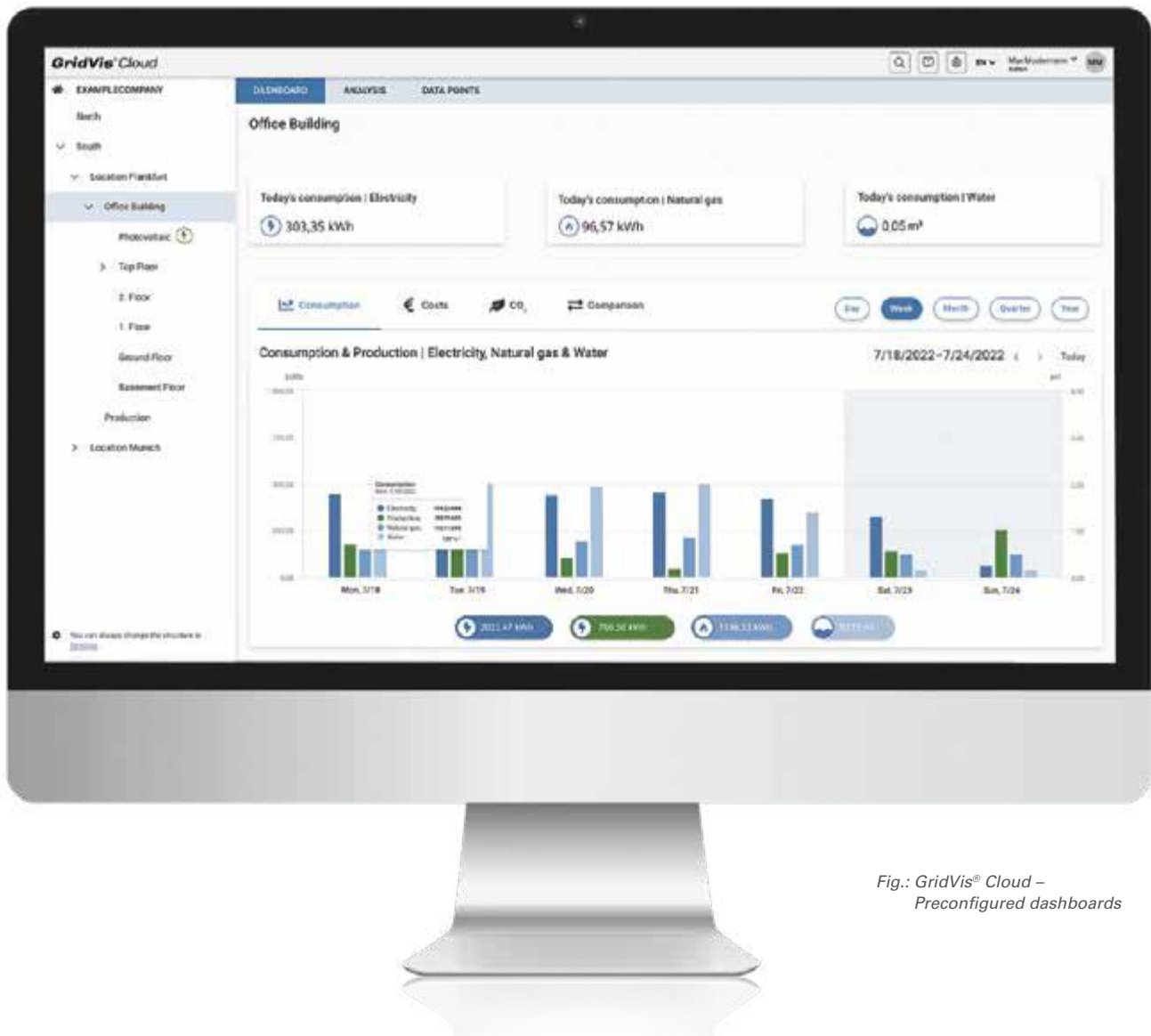

Fig.: GridVis® Cloud –
Preconfigured dashboards

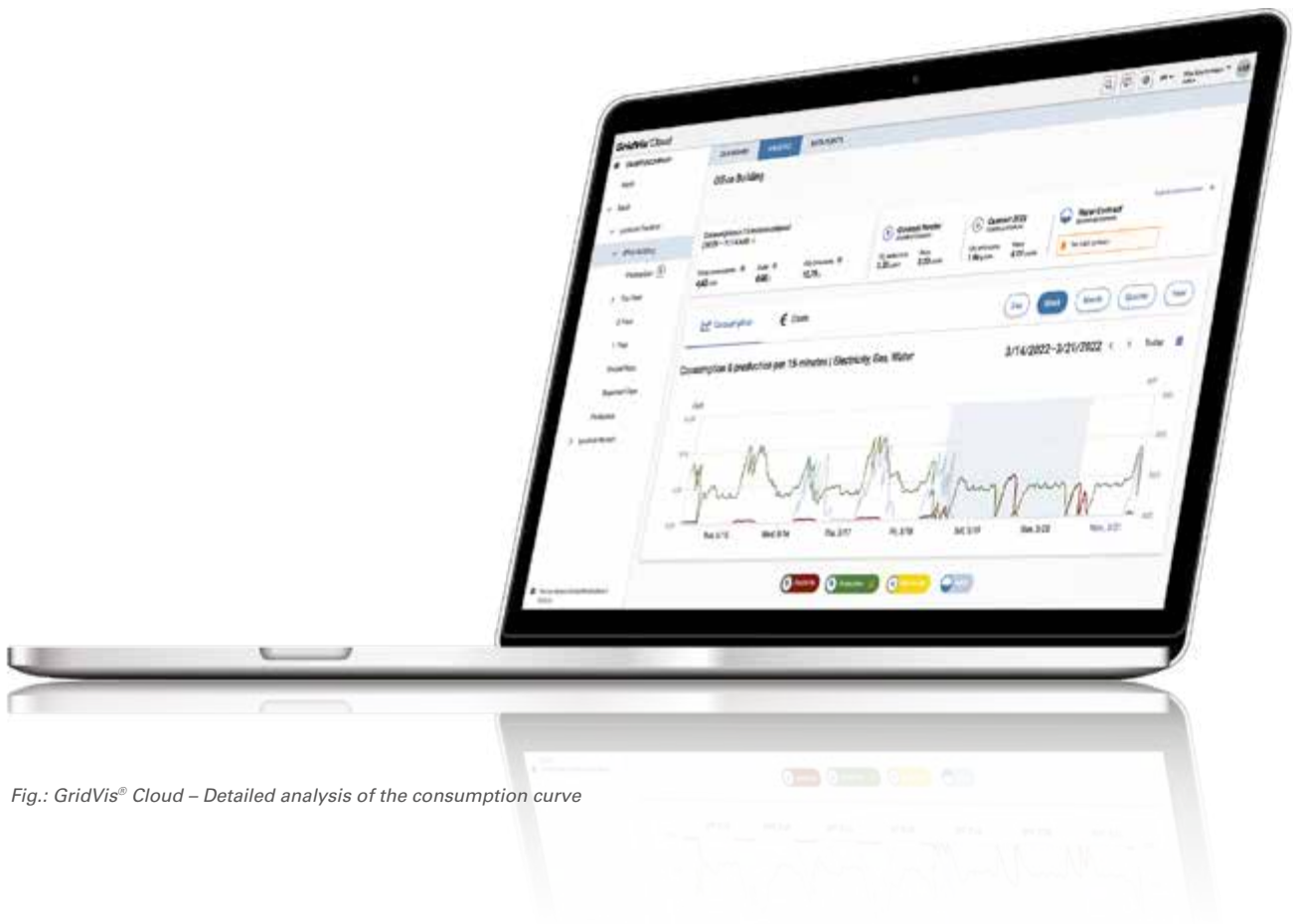

Fig.: GridVis® Cloud – Detailed analysis of the consumption curve

ANALYSIS

- Flexible and detailed analysis with one click
- Display of the consumption history in a line diagram
- "Current" consumption in the last 15-minute measuring interval
- Numerical consumption data
- Indication of measurement gaps
- Consumption and costs in a chart for the selected period as well as the possibility to switch to the cost view
- Quick, clear comparison with the previous period in a bar chart
- Individual time instant selection and fast time shift

LICENSING

The GridVis® Cloud can be licensed in different sizes, so it remains scalable and you only pay for the items you really need.

Item packages

The item packages determine how many items are available to you in the GridVis® Cloud. You need to consider how many items – users and measurement devices – you need for your project and then select an appropriate item package. The packages can be combined and supplemented later on as desired. Each item package is initially valid for a usage period of 1 year.

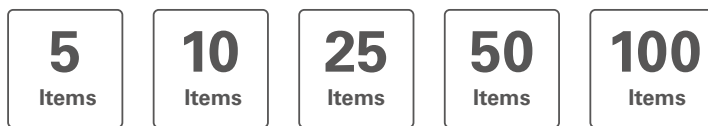

What are items?

Items are virtual units used to determine the size of the required GridVis® Cloud. An item represents a measurement device integrated or created in the cloud, or a created user, i.e. persons who are given access to the Cloud.



Extension – Extend the period of use

If the period of use expires, the GridVis® Cloud can no longer be used. So, extend your period of use in time by 1 or 3 years.

Calculation example – this is how the required items are calculated

GridVis® Cloud

Integrated measurement devices	7
Manually created measurement devices	2
Water meters (via Modbus)	2
Users via Janitza ID	3
<hr/>	
Total items	14
Item packages required	10 + 5 = 15
Items still available	1

CLOUD CONNECTOR

The Cloud Connector at a glance

- Connects the measurement equipment with the GridVis® Cloud
- Available in different versions for specific applications
- DIN rail mounting or stand-alone
- Integrated local web frontend for configuration and status display
- Connection via Ethernet, encrypted data transfer to the Cloud

CLOUD CONNECTOR S

DIN rail mounted device / stand-alone

Up to 50 measurement devices

All measurement device types, except UMG 801

Ethernet

Integrated local web frontend

CLOUD CONNECTOR M

DIN rail mounted device / stand-alone

Up to 100 measurement devices

All measurement device types

Ethernet

Integrated local web frontend

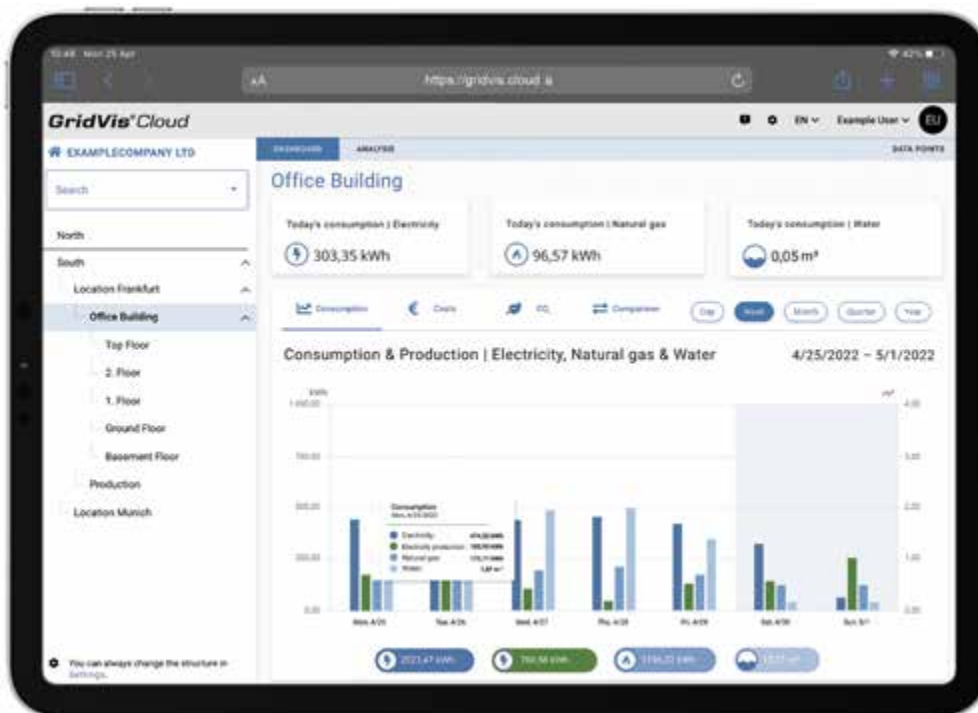
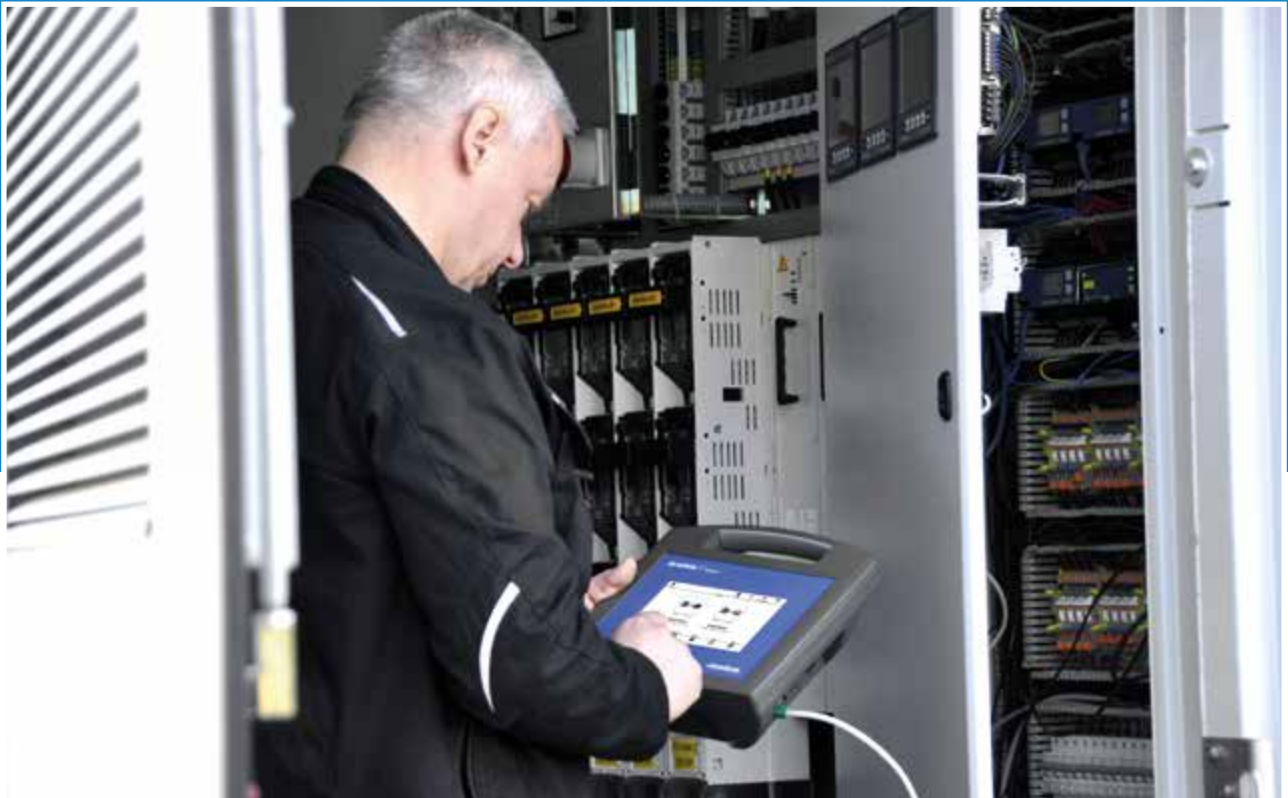

Fig.: Tablet-optimized display of the GridVis® Cloud

MOBILE DATA READOUT



As a mobile unit, the GridVis® Collector provides the option of reading measurement data from Janitza meters without an on-site communication link. This data can be compared and evaluated with other measurement points in a project. With a battery life of up to 9 hours, the GridVis® Collector can manage up to 500 meters. Its handling is easy to understand and can be performed in a few simple steps by an electrician.

The measurement data can be synchronized with a locally installed GridVis® via Ethernet or WLAN.

The GridVis® Collector provides the ideal solution for collecting measurement data in distribution stations or other self-supporting electrical distributions that have no radio or network link.

GridVis[®] COLLECTOR

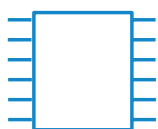

MEMORY

Collect and store data from up to 500 measurement devices



SAFETY

RSA encrypted data transmission



MOBILITY

Simple readout of autonomously operated measurement devices

GridVis® COLLECTOR – DIMENSIONED DRAWING

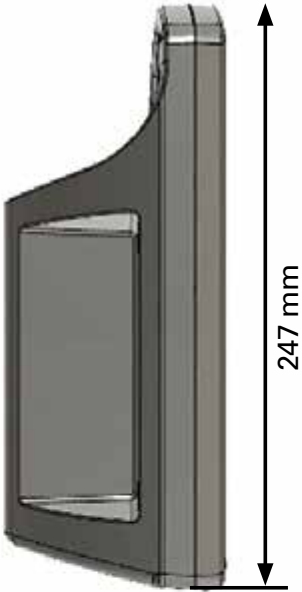
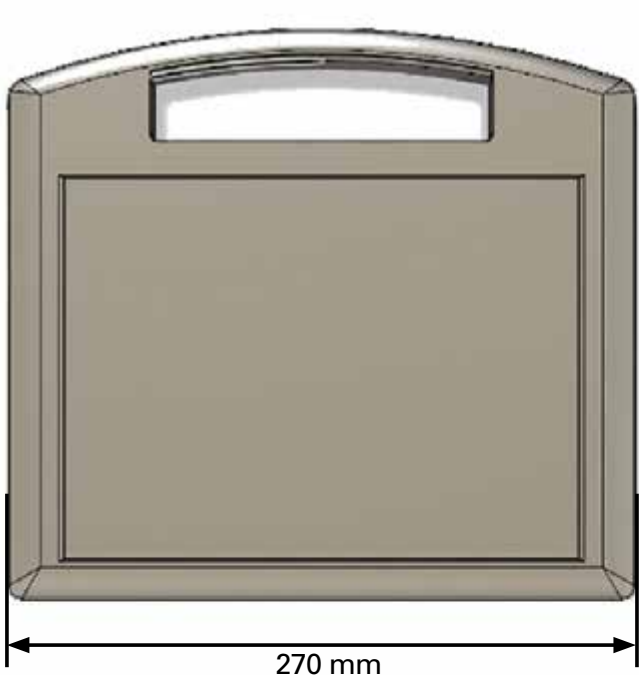

GridVis® COLLECTOR – CONNECTIONS AND CONTROLS



GridVis® COLLECTOR		
PART NUMBER	5100400	
NO.	DESIGNATION	DESCRIPTION
1	Display	7" capacitive multi-touch color display
2	WLAN	Integrated antenna (inaccessible from the outside)
3	On/Off button	Switches the device on and off (press the button briefly for each). Reset the device (keep button pressed for approx. 10 sec.). Only perform the reset in an emergency and after instruction from the manufacturer!
4	Status LED	Display of the operating modes: Green - device in operation Blue - device in charging state, battery is full Red - device in charging state Orange - the device is shutting down Yellow - charge/timeout
5	Mini-USB charging port	Connection for charging the device (batteries) Mini-USB port USB-BC 1.2 Charging current 1.5 A at 5 V
6	USB 2.0 port	Connection for initial commissioning and the USB/RS-485 converter
7	Ethernet port	100Base-T Status indication on the display "Ethernet cable connected"

GridVis® COLLECTOR – TECHNICAL DATA

GridVis® COLLECTOR		
PART NUMBER	1401627	
GENERAL		
CPU	ARM Cortex	
Main memory	1 GB LPDDR2	
Measured value memory	60 GByte	
Open ports	80, 21, 502, 8082-8084 ¹⁾	1) ...communication port, depending on the setting in the Collector/GridVis® software configuration.
Operating system	Linux, Debian	
	Relative humidity	5% to 95% non-condensing
	Net weight	1250 g
	Protection level	IP20 according to EN60529
	Operating elevation	0 .. 2000 m above sea level
	Operating environment	Surfaces with clear contours and sufficient lighting (Lux >15)
	Dimensions	W270 mm x H247 mm x D91 mm
	Housing material	ASA+PC+FR (UL 94 V-0)
REQUIRED COMMUNICATION PORTS		
Open ports	80, 21, 502, 8082	Communication port, depending on the setting in the Collector/GridVis® software configuration.
Data exchange with the GridVis® software	80, 8082	Communication port for initial installation
Sending an error report to Janitza Support	80	Takes place via http
Readout of the measurement devices	80, 21, 502	
Synchronizing the internal clock with an NTP server on the Internet	123/UDP	ptbtime1.ptb.de
DISPLAY		
	Type	7" TFT
	Luminosity	250 cd/m ²
	Viewing angle	140 degrees horizontal, 130 degrees vertical
	Resolution	800 x 480 pixel, RGB LCD
	Touch display	Capacitive, multi-touch (10 fingers)
	Color	24-bit color range
	Backlight service life	20000 h
BATTERY		
	Type	Lithium ion
	Capacity	3350 mAh
	Certification	UN83.3
	Design	Permanently installed, cannot be changed by the customer.
	Running time	Approx. 9 h at 50% backlight, approx. 7 h at 100% backlight. These are approximate values and depend on the age and use of the battery (e.g. the battery running time decreases with a constant WLAN connection).
	Charging time in off state	5 h
	Service life	80% - 300 cycles
	Maximum "Charging" temperature range (battery only)	0° C to +45° C (32° F to 113° F)
	Maximum temperature range (battery only)	-20° C to +65° C (-4° F to 149° F)
	Protection	BMS, PCM

WLAN 802.11B/G/N

Encryption	Open, WEP, WPA 2 (with CCMP and TKIP support)
Authentication	PEAP (with MSCHAPv2), TSL, TTLS
Frequency range	From 2.3995 to 2.4845 GHz
Can be switched off	Yes
Range	10 m

AMBIENT TEMPERATURE

Operating temperature range	0° C to 40° C (32° F to 104° F)
Storage/transport temperature range	-10° C to +45° C (14° F to 113° F)

Recommendation: For a long service life, store the device at 22 to 28 °C (71 - 82 °F) in a dry environment!

INTERFACES (USB 2.0)

Mini-USB charging port	USB-BC 1.2 specification (USB battery charging), charging up to 1.5 A
Ethernet port	100 Base TX

TRANSPORT CASE

Dimensions	W464 mm x H176 mm x D366 mm
Waterproof, dustproof	IP67 certified
Automatic pressure compensation valve	
Net weight	3340 g

USB CHARGER

Input	100–240 V, 50–60 Hz, 0.7 A
Output	5 V DC, 2.4 A

CLOCK BATTERY

Battery (soldered)	BR 1632, 3 V
Typical service life	5 – 8 years

INCREASE CONNECTIVITY

Extend the connectivity of GridVis® with the multi-protocol server (MPS) from NETxAutomation and use the option of providing measurement data at OPC UA level. The multi-protocol server from NETxAutomation, with an integrated GridVis® driver, is available exclusively from Janitza and can be used in addition to the OPC UA Client.

The server enables direct access to measurement data and key performance indicators of GridVis®. Clear advantages of the integrated driver include the little setup effort required and the high availability of all measurement data. In addition, the complete GridVis® meter structure is available directly in the OPC UA tree. The mounting of several GridVis® projects

is also supported. OPC UA clients, including the GridVis® OPC UA Client, building management systems, SCADA systems, ERP systems and many more can thus easily process online data from GridVis®. In addition to the direct GridVis® connection, the multiprotocol server offers KNX, BACnet, Modbus, SNMP, OPC, MQTT as well as logic functions that are already included in the scope. Our partner, NETxAutomation, provides support with their many years of experience in OPC UA and building automation. The Janitza specialists are well-trained to support you in the installation and commissioning of the server upon request.

MULTIPROTOCOL SERVER

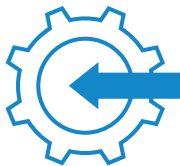

INTEGRATION

Low setup effort
and high availability



COMMUNICATION

Process data system-
independently



COST SAVINGS

Low setup effort
due to integrated GridVis® driver

MULTIPROTOCOL SERVER – TECHNICAL DATA

MULTIPROTOCOL SERVER		
TYPE	DESCRIPTION	PART NO.
Multi Protocol Server 1000	<ul style="list-style-type: none"> – Server including GridVis® driver – Compatible with GridVis® Standard and Expert* editions – For a direct GridVis® service connection – 1000 data points included – Including SNMP, BACnet, OPC UA clients – Licensing softkey 	5100155
Multi Protocol Server 2500	<ul style="list-style-type: none"> – Server including GridVis® driver – Compatible with GridVis® Standard and Expert* editions – For a direct GridVis® service connection – 2500 data points included – Including SNMP, BACnet, OPC UA clients – Licensing softkey 	5100156
Multi Protocol Server 5000	<ul style="list-style-type: none"> – Server including GridVis® driver – Compatible with GridVis® Standard and Expert* editions – For a direct GridVis® service connection – 5000 data points included – Including SNMP, BACnet, OPC UA clients – Licensing softkey 	5100157
Multi Protocol Server 10000	<ul style="list-style-type: none"> – Server including GridVis® driver – Compatible with GridVis® Standard and Expert* editions – For a direct GridVis® service connection – 10,000 data points included – Including SNMP, BACnet, OPC UA clients – Licensing softkey 	5100158

** The Multi Protocol Server is also compatible with the GridVis® Service and Ultimate editions.*

Note: The multiprotocol server is a stand-alone application and can be purchased in addition to GridVis®. Billing is based on required data points.

We will be delighted to provide you with a customized offer.

COMPLETE SERVER WITH GridVis® AND DATABASE

DATABASE SERVER

- Trouble-free, immediate use
- Simple and fast integration of the configured server into the existing network
- The GridVis® software is already installed on the database server
- Available databases: Janitza DB, MS SQL or MySQL
- Dell PowerEdge server
- Data security through RAID-10 systems with HotPlug hard disks

GUARANTEED ALL-ROUND SERVICE

- Access to database servers thanks to Janitza maintenance diagnostics and troubleshooting after approval
- Quickly diagnose and fix problems
- Highest safety: Use of common remote maintenance solutions with three-level industry-standard encryption

APPLICATIONS

- GridVis® runs as a service on the server
- User login not required
- For measured value analysis, the client computers access the server directly via the network
- Access to measurement data within the database by any number of client systems possible
- Visualization of historical data via the database, online measured values available directly from the device

DATABASE SERVER

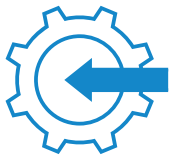

INTEGRATION

Simply integrate, use immediately



SAFETY

High data security with maximum performance



EXPANDABLE

Quickly and easily expand and scale

DATABASE SERVER

Extensive measured value analysis requires powerful server solutions

- Janitza electronics GmbH offers a powerful server as a complete solution
- Trouble-free, immediate use is ensured
- Simple and fast integration of the configured server into the existing network
- The GridVis® software is already installed on the database server
- Available databases: Janitza DB, MS SQL or MySQL
- Use of a powerful tower or rack server from Dell
- The Dell PowerEdge server offers high quality and reliability with maximum expandability
- The use of RAID 10 systems with HotPlug hard disks ensures maximum data security

Guaranteed all-round service

- Access to database servers thanks to Janitza maintenance diagnostics and troubleshooting (only with approval)
- Fast diagnosis and elimination of problems is possible
- Highest safety: Use of common remote maintenance solutions with three-level industry-standard encryption

For larger projects, we currently recommend the following configuration:

- Current Intel processor
- 16 GB RAM
- RAID controller
- RAID 10 with 4 hard disks of 1 TB capacity each
- DVD ROM drive
- Windows 2019 server with 5 CALs, 64-bit (German or English version)
- Installation of the GridVis® software and the database driver for SQL servers
- Databases MySQL / MS SQL are to be provided
- The integration of the server into the company's own network must be carried out via the customer's in-house administration

Offers on request



Fig.: Server (tower)



Fig.: Server (rack)

Areas of application

- For extensive monitoring systems with a large number of measurement devices
- For applications that require high data security and maximum performance
- For companies whose systems are to be scalable and expandable

Application

- GridVis® runs as a service on the server
- User login not required
- For measured value analysis, the client computers access the server directly via the network
- Access to measurement data within the database by any number of client systems possible
- Display of online measured values depends on the number of ports per device, i.e. visualization of historical data via the database, online measured values available directly from the device

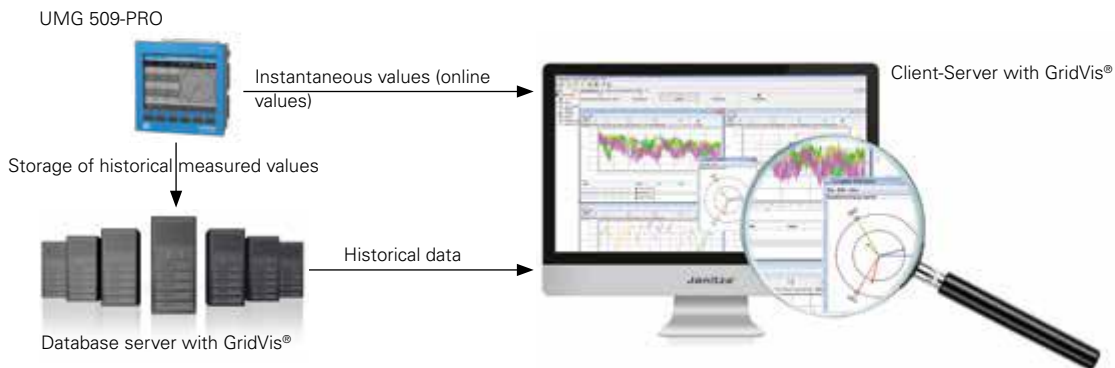

Fig.: The UMG 509-PRO, for example, currently has 6 communication ports. Two of them are designed as a gateway (port 8000) for downstream RS-485 devices.

DATABASE SERVER – TECHNICAL DATA

DATABASE SERVER		
TYPE	DESCRIPTION	PART NO.
Server (tower)	<ul style="list-style-type: none"> – Current Intel processor – 16 GB RAM – RAID controller – RAID 10 with 4 hard disks of 1 TB capacity each – DVD ROM drive – Incl. mouse and keyboard with German layout 	1506352 (German Windows version)
	<ul style="list-style-type: none"> – Windows 2019 server with 5 CALs, 64-bit (German or English version) <p>Note:</p> <ul style="list-style-type: none"> – GridVis® software and database driver for SQL server – The MySQL / MS SQL databases are to be provided by the customer – The integration of the server into the company's own network must be carried out via the customer's in-house administration – Warranty from Dell GmbH 	1506353 (English Windows version)
Server (rack)	<ul style="list-style-type: none"> – Current Intel processor – 16 GB RAM – RAID controller – RAID 10 with 4 hard disks of 1 TB capacity each – DVD ROM drive 	1506354 (German Windows version)
	<ul style="list-style-type: none"> – Windows 2019 server with 5 CALs, 64-bit (German or English version) <p>Note:</p> <ul style="list-style-type: none"> – GridVis® software and database driver for SQL server – The MySQL / MS SQL databases are to be provided by the customer – The integration of the server into the company's own network must be carried out via the customer's in-house administration – Warranty from Dell GmbH 	1506355 (English Windows version)
Setup package 1 for MS SQL	<ul style="list-style-type: none"> – Install hard disks – Install operating system – RAID configuration (RAID 10) – Install updates – Install MS SQL server* – Install GridVis® 	5101018
Setup package 2 for My SQL	<ul style="list-style-type: none"> – Install hard disks – Install operating system – RAID configuration (RAID 10) – Install updates – Install MySQL server* – Install GridVis® 	5101019
Setup package 3 for JanDB	<ul style="list-style-type: none"> – Install hard disks – Install operating system – RAID configuration (RAID 10) – Install updates – Set up JanDB – Install GridVis® – Set up RTP User 	5101023

* The MS SQL or MySQL database is to be provided by the customer. GridVis® software and database drivers are separate items. The integration of the server into the company's own network must be carried out via the customer's in-house administration. Hardware warranty from Dell GmbH.

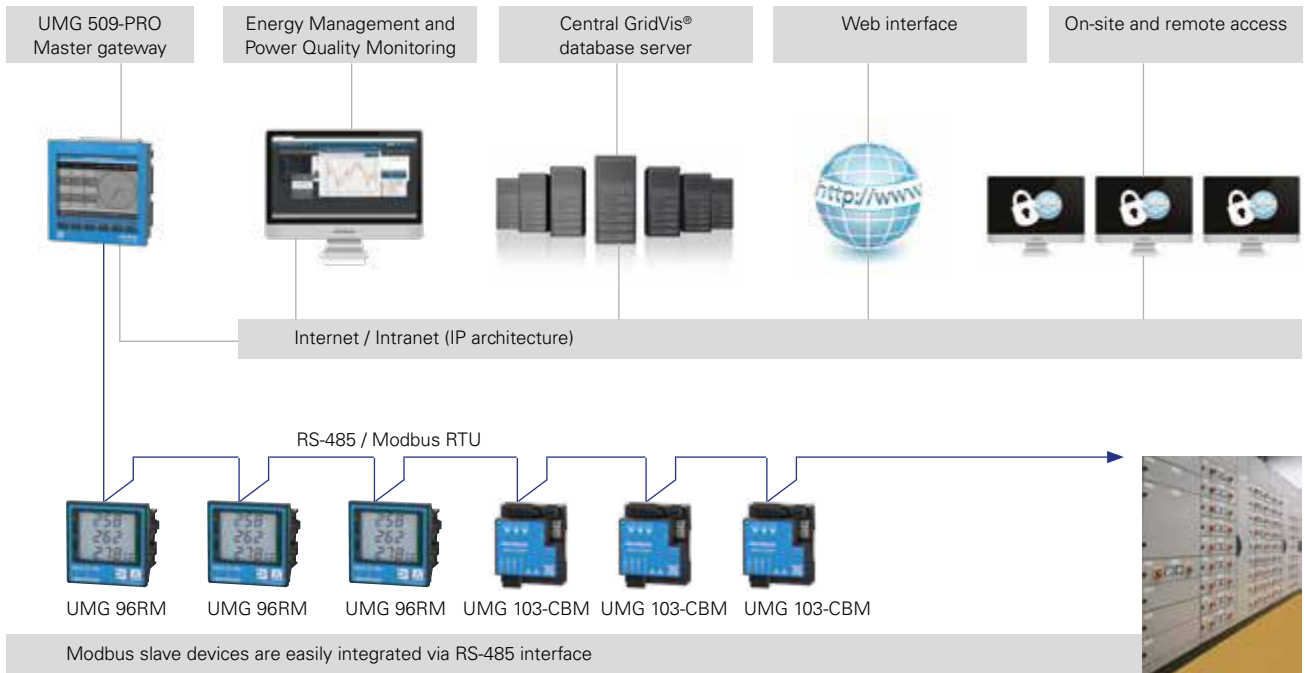
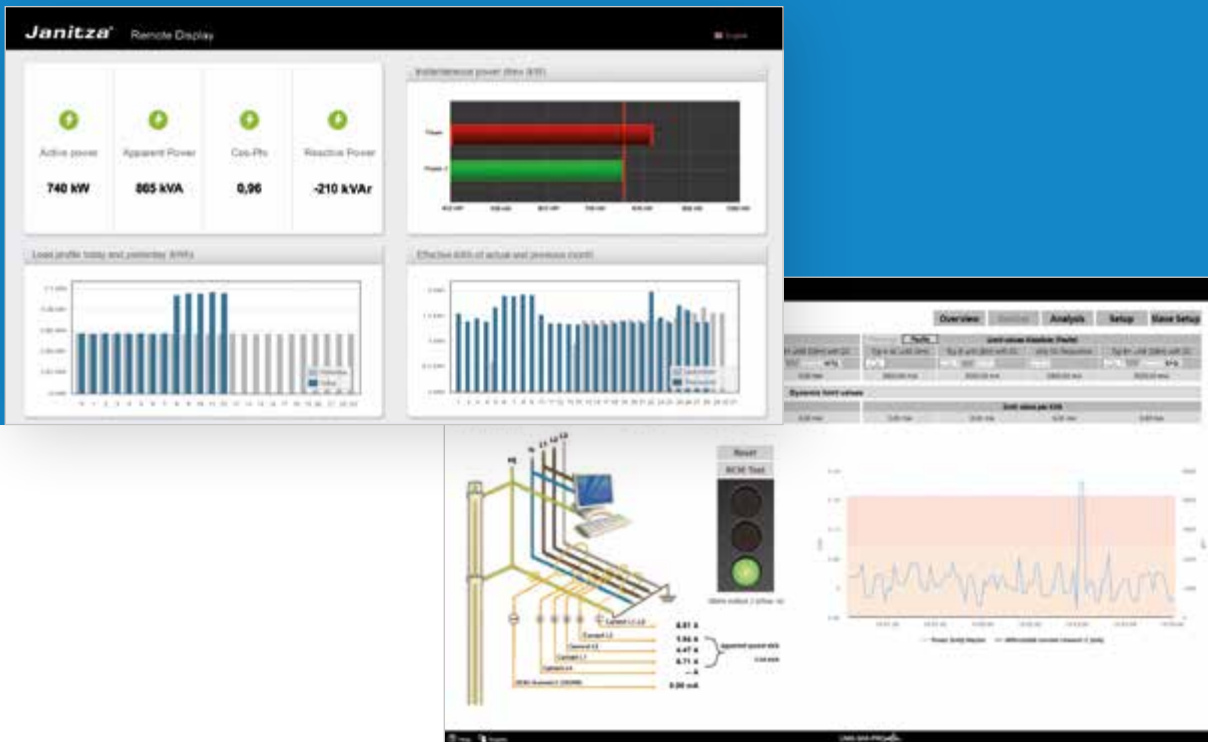

Fig.: Master-slave communication architecture

ENHANCEMENTS WITH KNOW-HOW

- Integrated functions in the device can be expanded, controlled and visualized via APP
- Consists of several Jasic®, Flash and Homepage files, depending on the application (administration and installation are carried out via the GridVis® software)
- The programming language for creating APPs is Jasic®
- Alternatively, programming can also be done graphically with GridVis®
- Development of further APPs for the measurement devices by users and third-party suppliers is possible
- APP creation requires programming skills in Jasic®, JAVA Script, JSON, AJAX or Action Script, depending on the application

APPS



EXPANDABLE

Quickly add desired functions

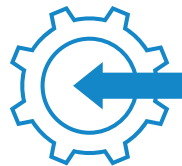

INTEGRATION

No installation required, directly available



OPERATING CONVENIENCE

Quick navigation through selected measurement data

APPS – TECHNICAL DATA

APPS		
DESCRIPTION	SUITABLE FOR	PART NO.
Alert messenger*1 Configurable Jasic® program for sending error messages by email	UMG 604 / UMG 605 / UMG 509 / UMG 512 and PRO series	5100209
EN 50160 Watchdog*1 Integrated "Watchdog" function for continuous monitoring according to EN 50160	UMG 605 / UMG 512 UMG 605-PRO / UMG 512-PRO	5100264 5100305
FBM10PT1000*2 Up to 10 additional temperature inputs can be realized via the RS-485 interface by means of a hardware extension	UMG 604 / UMG 605 / UMG 509 / UMG 512 and PRO series	5100211
GPS Sync Synchronization of the device time via a digital input. To use the APP requires the GPS receiver, part no. 15.06.240	UMG 604 / UMG 605 / UMG 509 and PRO series	5100291
Humidity/temperature sensor JFTF-I*3 Processing and recording of up to 8 humidity/temperature sensors possible	UMG 604 / UMG 605 / UMG 509 / UMG 512 and PRO series UMG 605 / UMG 512	1506337 5100265
IEC61000-2-4 Watchdog*1 Integrated "Watchdog" function for continuous monitoring according to IEC 61000-2-4	UMG 605-PRO / UMG 512-PRO UMG 604 / UMG 509 UMG 604-PRO / UMG 509-PRO	5100306 5100309 5100308
Mini EnMS*1 Display of current and historical measured values in figures and charts from a master device and max. 15 UMGs with no memory on the device's own homepage	UMG 604 / UMG 605 / UMG 509 / UMG 512 and PRO series	5100266
Multitouch*4 Readout of 30 measured values and max. 31 slave devices via RS-485	UMG 604 / UMG 605 / UMG 509 / UMG 512 and PRO series	5100207
RCM analysis Extensive options for setting limit values and analyzing residual currents in detail. Up to 20 RCM channels can be managed and evaluated via a gateway. The evaluation covers all residual current types with an associated frequency analysis. In addition, the application supports the proven dynamic definition of limit values with Janitza energy measurement devices.	UMG 604-PRO / UMG 605-PRO / UMG 509-PRO / UMG 512-PRO	5100312
SNMP*1 Limit value monitoring with alarm function (SNMP trap)	UMG 604 / UMG 605 / UMG 509 / UMG 512 and PRO series	5100310

*1 Serial number is required
 *2 Free APP suitable for part no.: 1506077
 *3 Free APP suitable for part no.: 1506074
 *4 Also required for BACnet if slave devices are to be visualized via RS-485

APP ALERT MESSENGER

Part no. 5100209

- Configurable Jasic® program for sending error messages by email
- Depending on the configuration, error messages are sent in case of the following events:
Total harmonic distortion for voltage exceeded, momentary interruption detected, transient detected
- Storage of the meter readings of the event and transient messages in the Modbus register
- Possibility to monitor further measured values via an interface (not included)
- Emails with consumption values for the day, week and month can be sent (a non-encrypted mail server is required)
- Serial number is required

Suitable for: UMG 604 / UMG 605 / UMG 509 / UMG 512 and PRO series

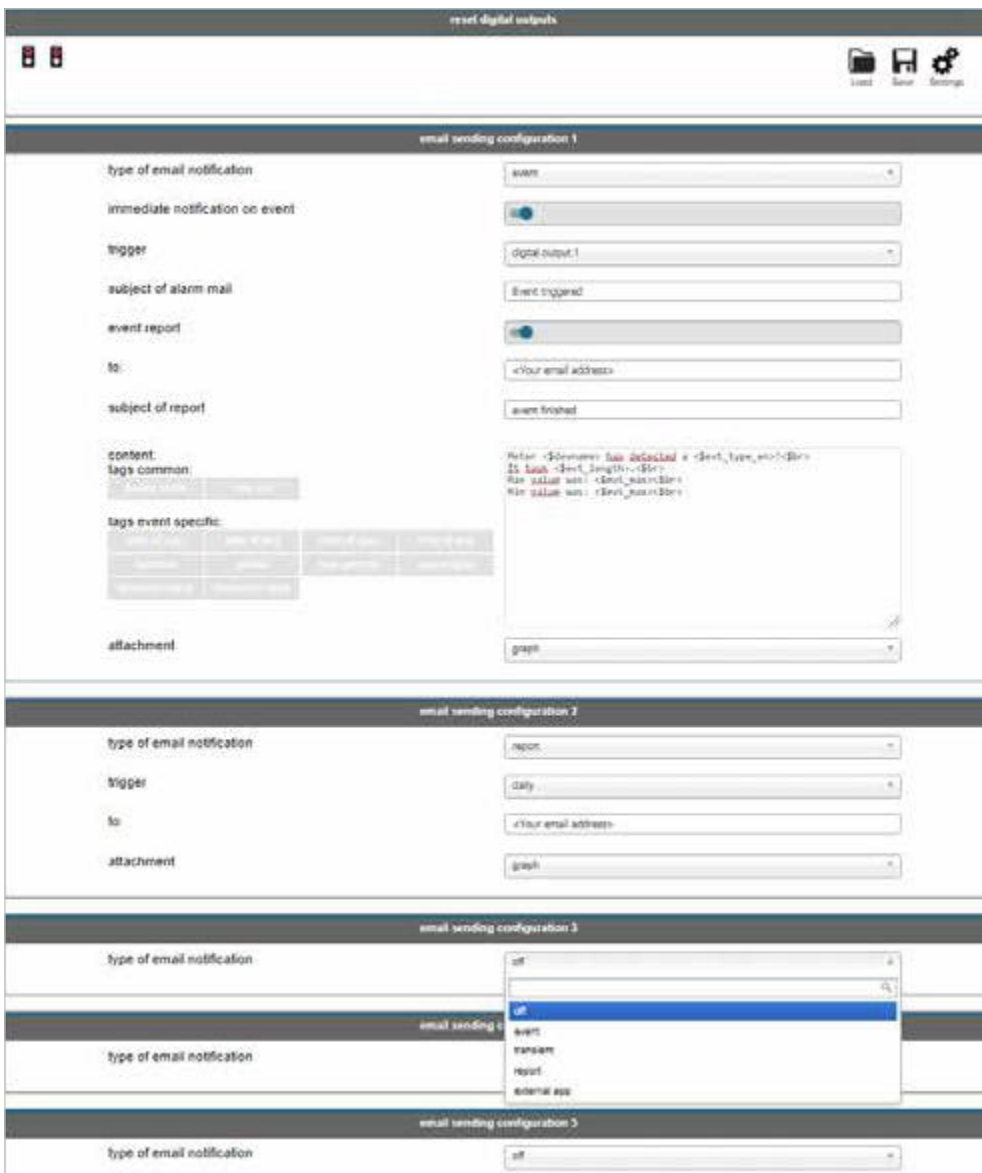

APP EN 50160 WATCHDOG

Part no. 5100264 & 5100305

Integrated "Watchdog" function for continuous monitoring of power quality according to EN 50160. The power quality on the supply side should comply with EN 50160. This standard describes various power quality parameters for the distribution of electrical energy in public mains networks. EN 50160 refers to the mains voltage, i.e. the voltage measured at the grid connection point. For power quality monitoring according to EN 50160, all algorithms (including the 95% and 100% values) are integrated in the measurement device itself. The auxiliary voltage of the device must be buffered so that voltage failures can be recognized as events.

- Integrated watchdog function
- No need to transfer large amounts of measurement data from the measurement device to a host system
- Communication cost savings in applications with remote consumers
- Simple analysis through integrated color display according to the traffic light principle
- Power quality analysis also possible without special PQ knowledge
- No alarm functionality
- Serial number is required

Part no. 5100264 suitable for: UMG 605 and UMG 512

Part no. 5100305 suitable for: UMG605-PRO and UMG 512-PRO

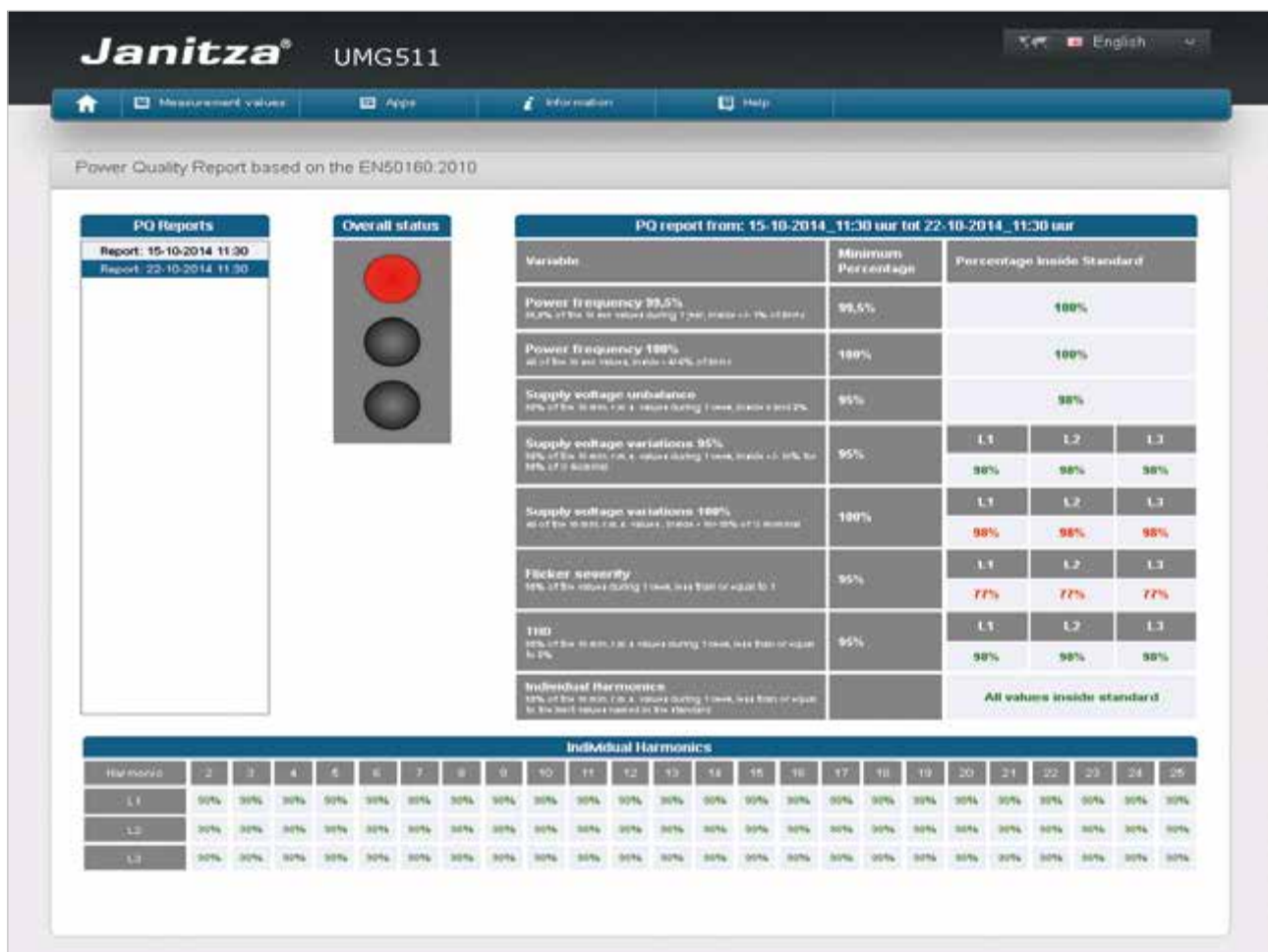

APP FBM10PT1000

Part no. 5100211

- Up to 10 additional temperature inputs can be realized via the RS-485 interface
- The hardware extension FBM10PT1000 – a DIN rail module with 10 PT1000 inputs – is required for this purpose

Suitable for: UMG 604 / UMG 605 / UMG 509 / UMG 512 and PRO series

The screenshot displays a web browser window with the URL <http://www.janitza.de/>. The page features a navigation menu with options like 'Start', 'Produkte', 'Service', 'Über uns', and 'Kontakt'. Below the menu, there is a large banner image of a city at night. The main content area is titled 'UV 1 FBM10 PT1000' and displays a list of temperature sensors with their current readings in degrees Celsius. A 'goto Master Page' button is visible on the left side. At the bottom, there is a status bar showing '3333 8 - overflow / no sensor' and the Janitza logo.

Sensor Type	Temperature (°C)
Temp Sensor 1	22.6
Temp Sensor 2	22.8
Temp Sensor 3	22.7
Temp Sensor 4	22.9
Temp Sensor 5	22.6
Temp Sensor 6	22.6
Temp Sensor 7	22.5
External Temp Sensor UMG604	22.6

APP GPS SYNC

Part no. 5100291

- Synchronization of the device time via a digital input.
- No NTP server required
- Easy installation
- Accuracy +/-1 s per GPS synchronization
- A GPS receiver (part no. 15.06.240), available as an accessory, is required
- This APP is not required for the UMG 512-PRO, as the GPS receiver can be connected to digital input 1 of the UMG 512-PRO without APP

Suitable for: UMG 604 / UMG 605 / UMG 509 and PRO series

APP HUMIDITY/TEMPERATURE SENSOR JFTF-I

Part no. 1506337

- Can process and record the measured values of up to 8 temperature/humidity sensors (part no. 15.06.074)
- The measured values are displayed via a homepage after installation of the APP or in GridVis® via global variables
- Measured values can be stored in a second Jasic® program via graphical programming
- Supplies two analog 4...20 mA output signals which are processed by the function module FBM DI8AI8 (part no. 15.06.079)

Suitable for: UMG 604 / UMG 605 / UMG 509 / UMG 512 and PRO series



APP IEC 61000-2-4 WATCHDOG

Part no. 5100265 & 5100306 & 5100309 & 5100308

Integrated "Watchdog" function for continuous power quality monitoring according to IEC 61000-2-4. The IEC 61000-2-4 standard specifies numerical limits for industrial and non-public power distribution systems at rated voltages up to 35 kV. For the consumer, the IEC 61000-2-4 standard should be applied for power quality. Consequently, the power quality in all technical installations must be monitored continuously according to IEC 61000-2-4 to ensure fault-free operation of the installed equipment. The auxiliary voltage of the device must be buffered so that voltage failures can be recognized as events.

- Integrated watchdog function according to the standard IEC 61000-2-4
- No need to transfer large amounts of measurement data from the measurement device to a host system

- Communication cost savings in applications with remote consumers
- Simple analysis through integrated color display according to the traffic light principle
- Power quality analysis also possible without special PQ knowledge
- No alarm functionality
- Serial number is required

Part no. 5100265 suitable for: UMG 605 and UMG 512

Part no. 5100306 suitable for: UMG 605-PRO and UMG 512-PRO

Part no. 5100309 suitable for: UMG 604 and UMG 509

Part no. 5100308 suitable for: UMG 604-PRO and UMG 509-PRO

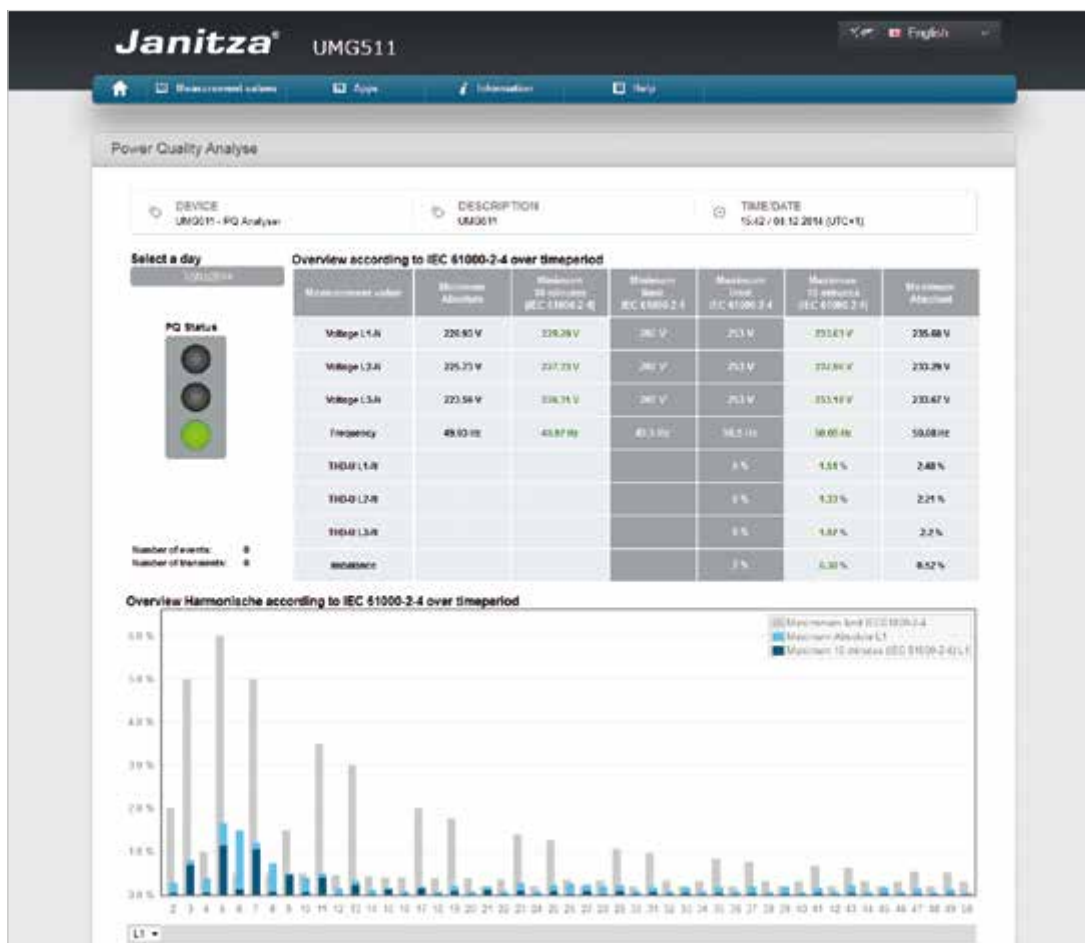

APP MINI ENMS

Part no. 5100266

The APP "Mini EnMs" is used to set up a small, local, web-based energy management system for a maximum of 16 Janitza devices with no memory. Online and historical data of the master and slave devices are displayed via the web-based user interface. The master device also serves as a data logger for the slave devices.

- Optimized for use on PCs, laptops or tablet PCs
- Selection of measured variables of the master device and the slave devices via drag and drop
- Selection of the desired time window using the integrated calendar function
- The main variables of the Modbus slaves are stored on the "Main measurement device" and are displayed there
- No external servers or software packages required; a standard browser is sufficient

- Maximum of 16 slaves (UMG 103-CBM or UMG 96RM)
- Storage variable for slave devices
 - Current L1, L2, L3
 - Sum of active power
 - Sum of apparent power
 - Sum of active energy
- The master collects the data and makes it available on its own device homepage.
The APP was developed for small applications without the use of GridVis®.
- Serial number is required

Suitable for: UMG 604 / UMG 605 / UMG 509 / UMG 512-PRO and PRO series

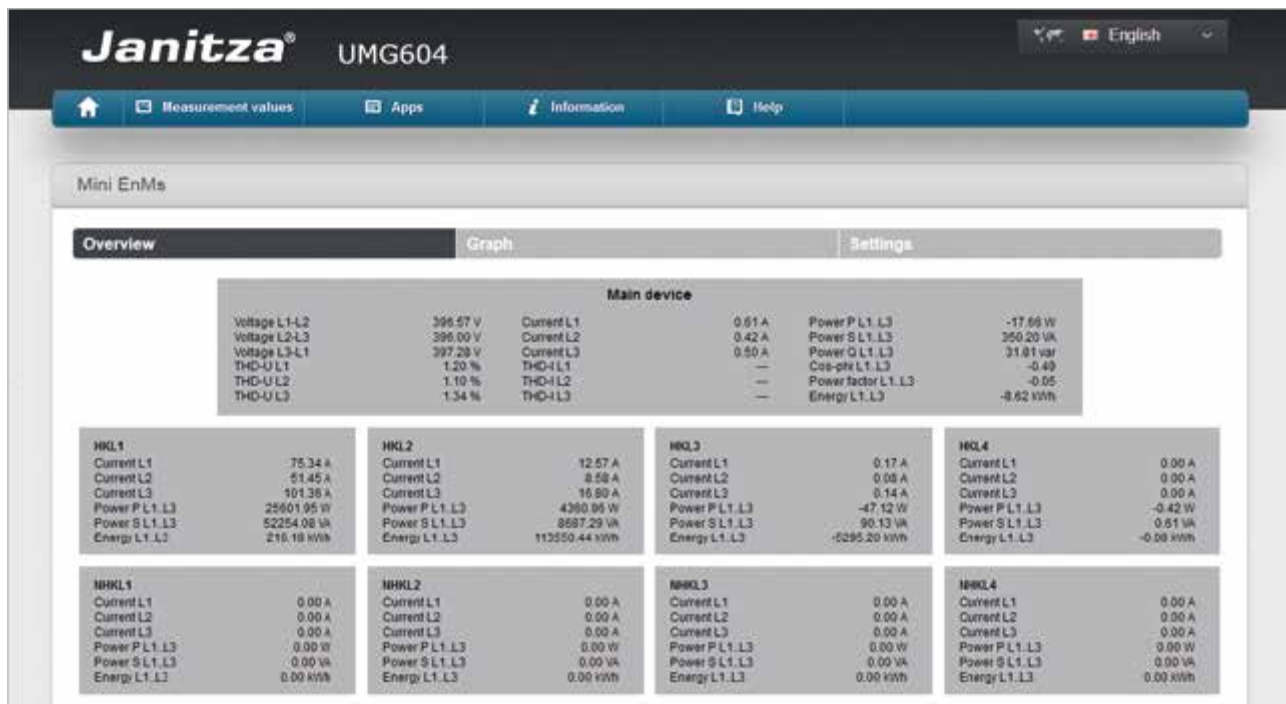

APP MULTITOUCH

Part no. 5100207

- Reads out 30 measured values (fixed presets) from up to 31 slave devices (configurable) via RS-485
- Storage of the measured values in the master on global variables or on BACnet data points
- Display of the measured values via the homepage of the device (browser with FLASH plug-in required)
- Extension for live value display
- Integrated BACnet gateway function (option, part no. 5216083)
- The BACnet ID can be changed via the homepage
- The program installs a control program
- Possible communication errors (RS-485 bus) directly visible via status display
- Number of devices and device description configurable via the master device homepage
- The master is automatically detected and is entered in the Device Type field
- The BACnet configuration is also carried out via the master device homepage
- Each device can be assigned its own BACnet ID
- An EDE file for importing the BACnet data points into a BACnet BMS is included in the scope of delivery of the APP

Suitable for: UMG 604 / UMG 605 / UMG 96-PN / UMG 96-PA / UMG 509 / UMG 512 and PRO series



Fig.: Overview page of the measured values



Fig.: Configuration page: Assignment of the names and basic settings



Fig.: BACnet configuration



Fig.: Measured value page slave view

APP RCM ANALYSIS

Part no. 5100312

- APP with extensive options for setting limit values and analyzing residual currents in detail
- Up to 20 RCM channels can be managed and evaluated via a gateway
- The evaluation covers all residual current types with an associated frequency analysis.
- For example, 50 Hz, pure DC or high-frequency residual currents in the 20 kHz range can be displayed individually
- This makes the type of error apparent quickly and the user knows where to look
- In addition, the application supports the proven dynamic definition of limit values with Janitza energy measurement devices.
- Energy meters can be assigned to each of the 20 RCM channels and limit values can be calculated as a function of performance

Suitable for: UMG 604-PRO / UMG 605-PRO / UMG 509-PRO and UMG 512-PRO

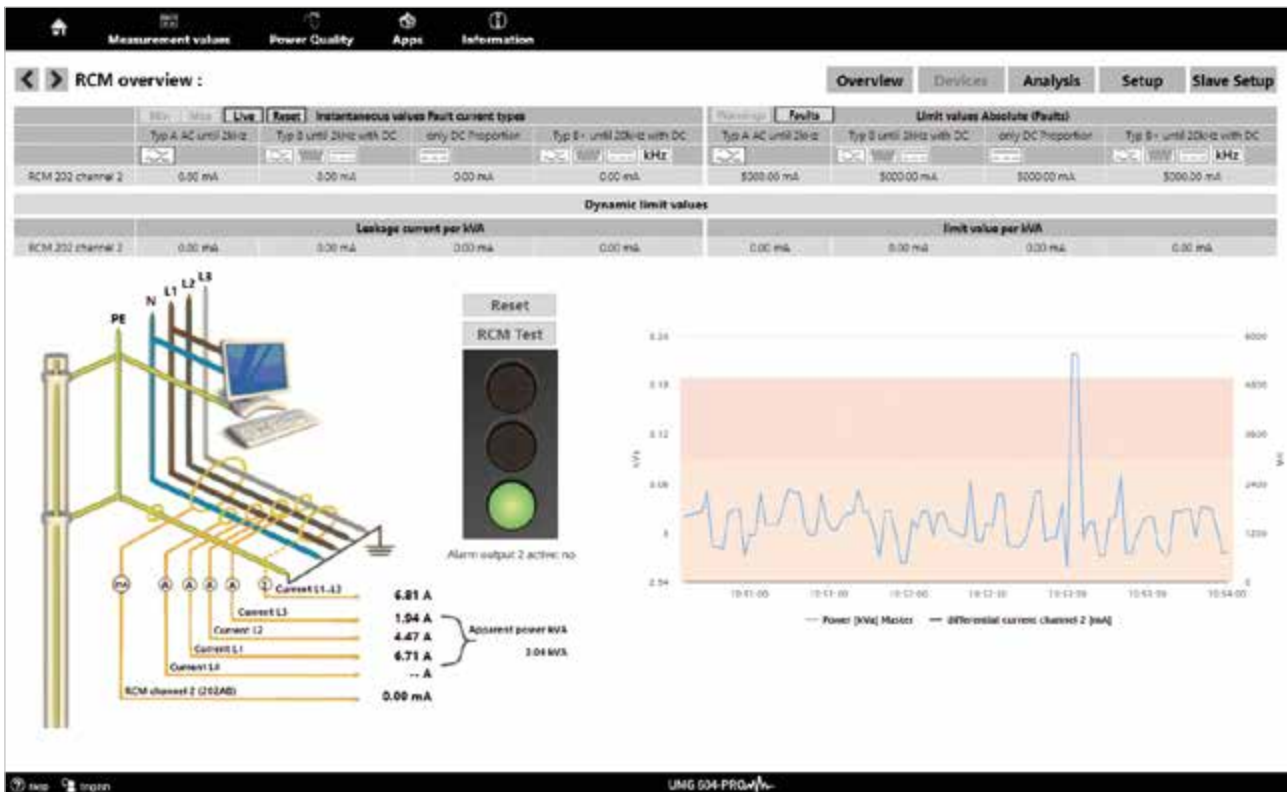

APP SNMP

Part no. 5100310

- APP monitors the limit values set on the website and in GridVis® and sends an SNMP trap if exceeded
- Freely configurable trap number
- Up to 2 hosts can be set
- Serial number is required

Suitable for: UMG 604 / UMG 605 / UMG 509 / UMG 512 and PRO series



Fig.: Configuration page on a UMG without RCM functionality



Fig.: Configuration page on a UMG with RCM functionality

ENERGY MANAGEMENT AND PQ ANALYSIS ONLINE

For users who do not need or do not want to install the GridVis® software, the measurement device's own homepage can be used. All that is required for access is a standard web browser and an Ethernet connection. Each measurement device has an integrated web server that provides a password-protected homepage. The device can be operated just as comprehensively via its homepage as via the device display. Online and historical measurement data (energy consumption by default) as well as power quality analysis can be retrieved. The display can be used to remotely control and configure the measurement device. Since a large number of PQ measured values can be displayed in addition to standard electrical values, for many users, the device homepage represents a basic configuration for a monitoring system.

- Access to the powerful device homepage via web browser
- No software installation necessary
- Online data, historical data and much more can be called up directly via the device homepage
- Functional enhancement through APPs possible
- Remote control of the device display via the homepage
- Password protection possible

DEVICE HOMEPAGE

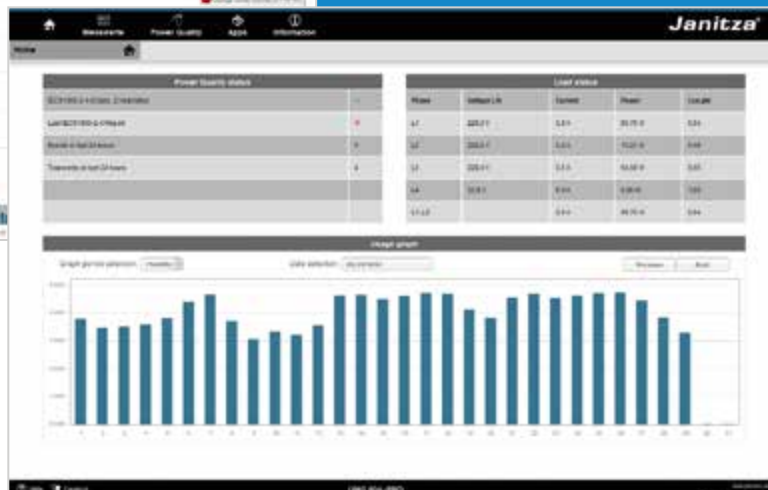
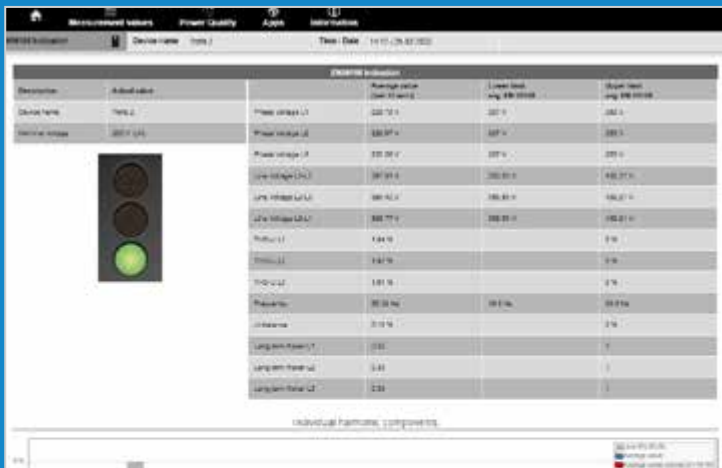

AVAILABILITY

Quick retrieval of important measurement data with no program installation



VISUALIZATION

Conveniently visualize and analyze data

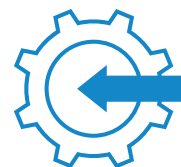

INTEGRATION

No installation necessary

PROGRAMMING LANGUAGE

- Special programming/script language for the meters UMG 604-PRO / UMG 605-PRO / UMG 509-PRO and UMG 512-PRO
- Enhance the functionality of the meter with your own tasks
- User-friendly, graphical programming for the creation and configuration of mathematical functions and logical operations
- Device's own digital outputs can be set and inputs can be evaluated effortlessly
- Process and describe registers of external devices via Modbus (license required)
- Freely configure limit violations, time switching functions or recording of special values
- Store created programs as a file or transmit them to the measurement device
- 7 memory locations with 128 kByte each
- Simultaneous running of the 7 programs
- The user can freely program the Jasic® source code

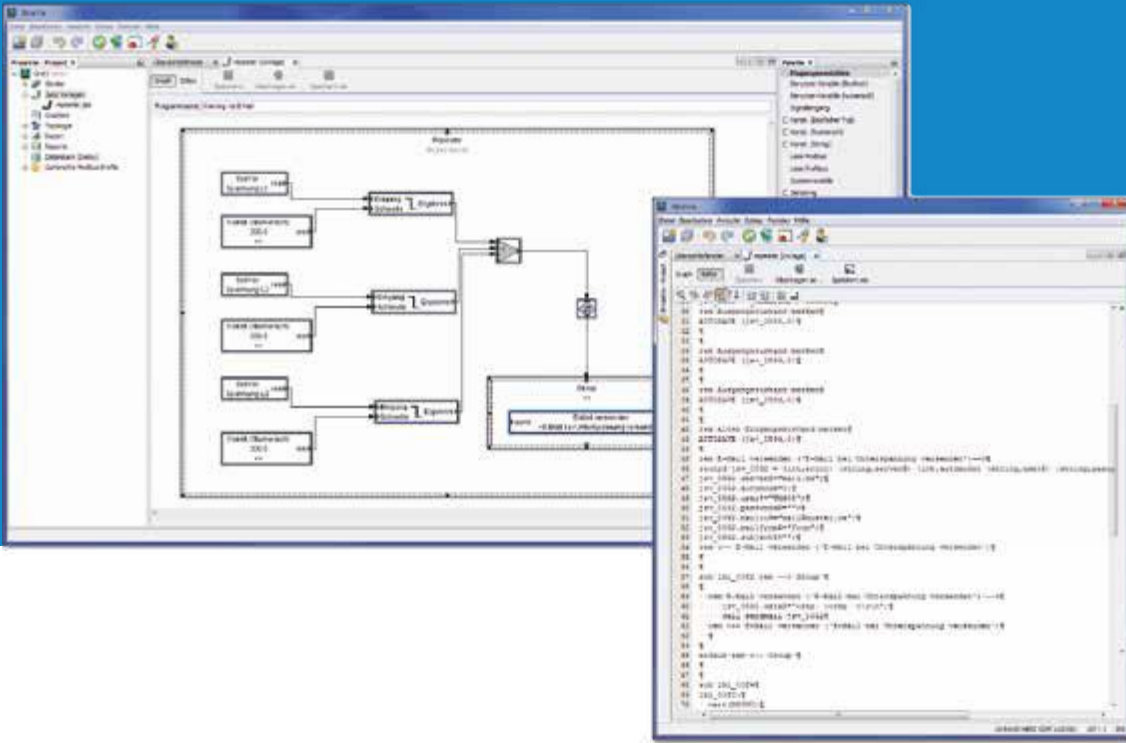

EXPANDABLE

Enhance devices with individual functions



SOLUTION-ORIENTED

Graphical, user-friendly programming



FLEXIBILITY

High flexibility due to extensive program functions

JASIC® PROGRAMMING LANGUAGE

Wide range of programming options

- User-friendly, graphical programming
- Custom enhancement of functions in the device
- Mathematical functions & logical operations
- Freely program the Jasic® source code
- Freely configure limit violations, time switching functions or recording of special values
- Set device's own digital outputs
- Evaluate digital inputs effortlessly

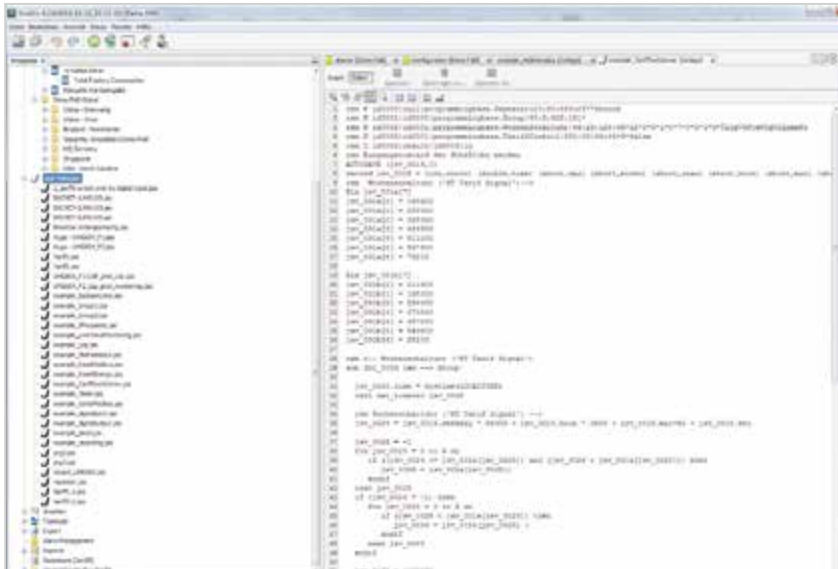

Graphical programming: Examples of limit value monitoring (comparator)

Example 1

- Monitoring of current L1: Definition of the threshold values by means of constants
- Digital output 1 indicates the exceeding of the predefined values

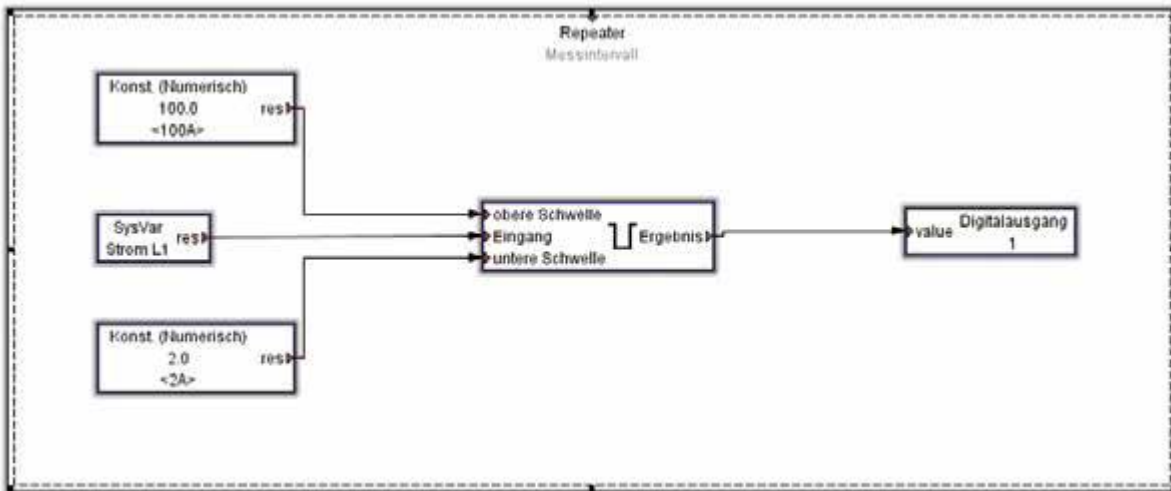

Example 2

- Operates with only one lower limit (in this case 100 A)
- When the current falls below 100 A, digital output 2 is activated

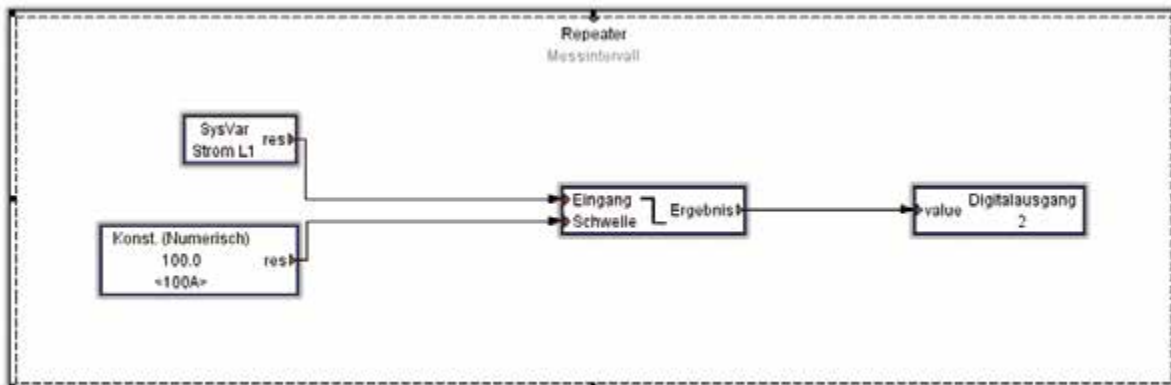

Graphical programming: Examples of limit value monitoring (comparator)

Example 3

- An email is sent when the predefined settings are exceeded
- In this example, the dispatch takes place with an undervoltage of $< 200\text{ V}$ in phases L1, L2 or L3
- Additional Information: Voltage values from the 3 phases at the time of the undervoltage

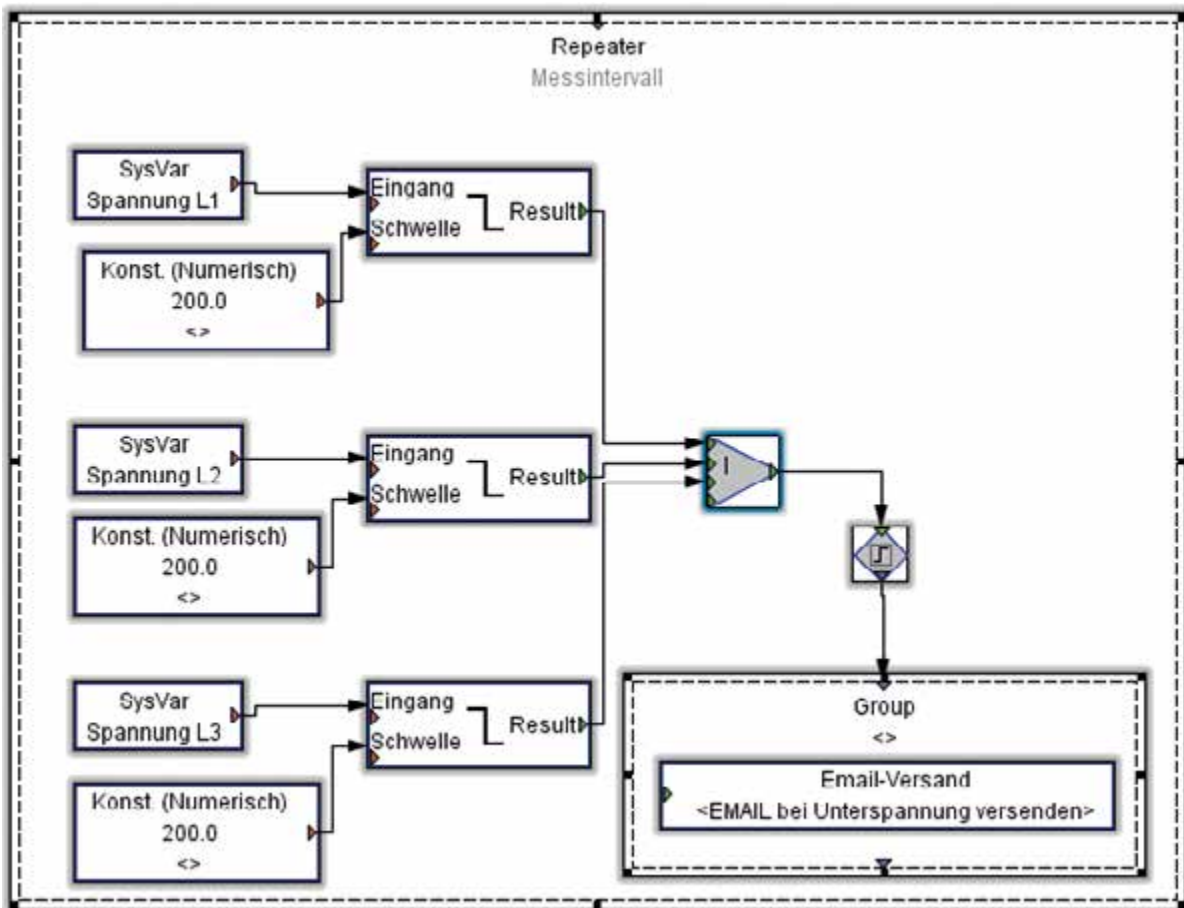

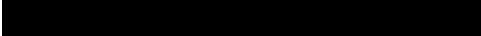



SERVICES – JANITZA SERVICE





- 354** Courses & training
- 358** Commissioning
- 362** Calibration
- 364** Mobile rental equipment
- 366** PQ Quick Check
- 367** Remote maintenance contracts
- 369** Other services

COURSES & TRAINING

JANITZA TRAINING OPPORTUNITIES

Whether you are operating a Janitza measurement device for the first time or want to gain more benefit from the data acquired – our training opportunities will take you further! You have the choice: In-house training at your site or regularly scheduled training in our training facility in Lahnau.

In-house training

We offer workshops for a maximum of eight participants with individually tailored content as part of an in-house training course.

Training opportunities in Lahnau

In the basic training course which takes place on two consecutive training days, you will learn how to configure

your measurement devices with the GridVis® Power Grid Monitoring Software and how to optimally evaluate and display the information obtained. This includes getting started with the software, installation (Planner version, limited to 5 devices) and mastering the most important basic functions. This training teaches safe procedures for the topics of energy management, power quality and residual current measurement. Building on this, the Janitza Expert Days offer deeper insights into individual topics. The following topics can be booked separately: Large-scale projects, energy management and residual current.

Our training facilitators will be happy to provide advice: training@janitza.de

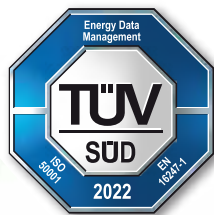

GridVis® COURSES

The GridVis® Power Grid Monitoring Software is a fundamental component for your energy management and power quality monitoring system. With GridVis®, measurement devices can be configured and the collected data can be displayed, visualized and analyzed. Our training courses range from

training for beginners to individual training courses as well as application and industry-specific conferences. In order to ensure learning objectives are achieved, each topic is enhanced through independent and practice-oriented exercises.

GridVis® COURSES	
DESIGNATION	PART NO.
Online training, GridVis® Standard , 1 day* Prerequisite: None	DL5101154
Online training, GridVis® Expert , 2 days* Prerequisite: None	DL5101155
GridVis® Webinar Training , 1 hour Seminar content by arrangement.	DL5101140

* Technical requirements: Internet-enabled PC, headset, use of TeamViewer for Windows on the participants' PC.

On-site training on request



GridVis® BASIC TRAINING

The goals of the GridVis® Basic Training are:

- Become familiar with important functions of the hardware and software
- Be able to create and manage your own projects using the GridVis® software
- Be able to configure Janitza meters correctly
- Be able to display and evaluate measurement and consumption data
- Be able to visualize measurement data using GridVis® Desktop and the GridVis® Energy web application
- Be able to protect your projects using a user management concept
- Be able to automate processes and create your own schedules
- Know how limit values are defined
- Be able to create your own alarm plans

Further focal points of the GridVis® Basic Training are:

- Installation, licensing and update of the GridVis® software
- In-depth examples of many system functions (user management, time management, automation, and much more)
- Create professional evaluations and reports
- Recording configuration for power quality and residual current monitoring
- Create your own dashboards and widgets
- Generate key performance indicators with evaluation system
- Create virtual measurement points and use them correctly
- Program different UMG meters using Jasic



GridVis® EXPERT TRAINING, FOCUS: ENERGY MANAGEMENT

- Practical seminar for people responsible for the implementation of DIN EN ISO 50001 in the company
- Overview of relevant standards and requirements
- Implementation tips for energy controlling and system optimization
- Workshop on key performance indicators and standardization



GridVis® EXPERT TRAINING, FOCUS: POWER QUALITY & RCM

- Practical seminar for people responsible for monitoring and evaluating power quality and residual current monitoring
- Overview of and requirements concerning relevant standards as well as recommendations
- Implementation tips for planning RCM monitoring
- Configuration, limit values and signaling paths
- Tips for PQ evaluations
- Solutions for optimizing power quality



GridVis® ONLINE COURSES

- **1 day (item no. DL5101154):** Introduction to GridVis® Desktop, visualization, data imports, automation, documentation, introduction to GridVis® Energy, dashboards and templates, user directory
- **2 days (item no. DL5101155):** As above plus additional integration of third-party devices, editor for reports, EnMS and EEG reports, alarm manager, OPC UA client, Sankey diagrams, key performance indicators (KPI), Jasic programming, HTML in GridVis®
- Required prior knowledge: None

COMMISSIONING

Janitza has decades of know-how in the field of energy measurement technology and complete monitoring systems. We will be happy to support you from the conceptual design to the commissioning of your monitoring solutions. This includes the complete range of tasks:

- Installation of the GridVis® system software
- Creation of customer projects in GridVis® with a measurement point structure
- Parameter configuration of the measurement devices, data loggers and other components to be integrated into the system according to customer specifications (form VBI for preparation)
- Checking the bus function and accessibility of the measurement devices
- Structure of graph sets
- Structure of topology views
- Briefing of operating personnel in the use of Janitza energy management system hardware and software components
- Official system handover

COMMISSIONING	
DESIGNATION	PART NO.
<p>Installation of GridVis® with up to 10 devices</p> <p>Installation of the GridVis® software on a PC or server including set up of the system by the manufacturer. Creation of a Janitza database or connection of an existing MySQL or MSSQL database, commissioning, instruction of the operating personnel, preparation of the final report with handover of the relevant data for hardware and software, topology configuration as well as GridVis® device list to the person responsible for the system.</p> <p>Travel costs/overnight stays will be charged additionally according to expenditure.</p>	DL5101090
<p>Installation of GridVis® with more than 10 devices</p> <p>Installation of the GridVis® software on a PC or server including set up of the system by the manufacturer. Creation of a Janitza database or connection of an existing MySQL or MSSQL database, commissioning, instruction of the operating personnel, preparation of the final report with handover of the relevant data for hardware and software, topology configuration as well as bus address list of the devices to the person responsible for the system.</p> <p>Travel costs/overnight stays will be charged additionally according to expenditure.</p>	DL5101091
<p>Installation of GridVis® on an additional computer</p> <p>Installation of GridVis® Desktop on an additional PC, incl. set up of the system by the manufacturer, instruction of the operating personnel, preparation of the final report.</p> <p>Travel costs/overnight stays will be charged additionally according to expenditure.</p>	DL5101092
<p>Acceptance/inspection/wiring</p> <p>Commissioning/acceptance of the physical wiring of the system by qualified personnel. Checking of Modbus/Ethernet cabling with regard to cable type, polarity, shield grounding, termination, patching of Ethernet connections, compliance with physical topology, etc. Preparation of communication and electrotechnical data lists in Excel format and handover to the person responsible for the system.</p> <p>Travel costs/overnight stays will be charged additionally according to expenditure.</p>	DL5101093
<p>Commissioning of a type 1 measurement device</p> <p>Programming of the parameters of the measurement device by the manufacturer, integration into the GridVis® software for the devices 509, 512, 604, 605, 801, 806, RCM202-AB, commissioning of the system, instruction of the operating personnel, backup of the configuration data as a text file.</p> <p>Travel costs/overnight stays will be charged additionally according to expenditure.</p>	DL5101094
<p>Commissioning of a type 2 measurement device</p> <p>Programming of the parameters of the measurement device by the manufacturer, integration into the GridVis® software for the devices UMG 103, UMG 96RM series, UMG 96-PA series, module 800-CT8-A, modules EC1, ED1, EI1, commissioning of the system, instruction of the operating personnel, backup of the configuration data as a text file.</p> <p>Travel costs/overnight stays will be charged additionally according to expenditure.</p>	DL5101095

COMMISSIONING	
DESIGNATION	PART NO.
<p>Commissioning of a type 3 measurement device Programming of the parameters of the UMG 20CM by the manufacturer, recording of the data on site, integration into the GridVis® software, commissioning of the system, instruction of the operating personnel, backup of the configuration data as a text file. Travel costs/overnight stays will be charged additionally according to expenditure.</p>	DL5101096
<p>Commissioning of a type 4 measurement device Programming of the parameters of the ProData 2 by the manufacturer, integration into the GridVis® software, commissioning of the system, instruction of the operating personnel, backup of the configuration data as a text file. Travel costs/overnight stays will be charged additionally according to expenditure.</p>	DL5101097
<p>Commissioning of a type 5 measurement device Programming of the energy meter parameters by the manufacturer, recording of the data on site, integration into the GridVis® software, commissioning of the system, instruction of the operating personnel, preparation of the final report. Travel costs/overnight stays will be charged additionally according to expenditure.</p>	DL5101123
<p>Commissioning of generic Modbus meters Programming of the parameters of Modbus measurement devices according to the manufacturer's release list of the Janitza electronics GmbH company via generic Modbus, implementation in the system, instruction of the operating personnel, backup of the configuration data as a text file. Travel costs/overnight stays will be charged additionally according to expenditure.</p>	DL5101102
<p>Commissioning of pulse media meters Programming of the parameters of the pulse media meters, setting of the pulse valencies, implementation in the system, instruction of the operating personnel. Travel costs/overnight stays will be charged additionally according to expenditure.</p>	DL5101103
<p>Commissioning of the Solvimus MBus Gateway Commissioning of the gateway by Janitza, recording of the data on site, integration in the GridVis® software, instruction of the operating personnel, preparation of the final report. Travel costs/overnight stays will be charged additionally according to expenditure.</p>	DL5101104
<p>Commissioning of MBus media meters Programming of the parameters of the M-Bus media meters for connection to the Solvimus MBus Gateway, recording of the data on site, setting of the M-Bus parameters, implementation in the system, instruction of the operating personnel, preparation of the final report. Travel costs/overnight stays will be charged additionally according to expenditure. Note: An overnight stay is required for 25 media meters or more.</p>	DL5101105
<p>Commissioning of OPC UA servers Installation/commissioning of Multi Protocol Servers by Janitza. Commissioning of the system, instruction of the operating personnel, preparation of the final report. Travel costs/overnight stays will be charged according to expenditure.</p>	DL5101106
<p>Integration in the OPC UA server Integration of a measurement device in the Multi Protocol server, recording of data on site, creation of approx. 5 measured values per measurement device, instruction of the operating personnel, preparation of the final protocol. Travel costs/overnight stays will be charged additionally according to expenditure.</p>	DL5101107
<p>Commissioning and parametrization of JPC100 Programming of the JPC100 parameters by the manufacturer, IP configuration, configuration of the alarm system, email configuration, backup of the configuration data Travel costs / overnight stays will be charged additionally according to expenditure. Note: For the integration of devices, the articles "IBN measurement devices type 1 to type 5" must also be selected.</p>	DL5101151
<p>Upgrade of GridVis® Upgrade of the existing and installed GridVis® software to a higher edition, incl. programming of the system by the manufacturer, commissioning, instruction of the operating personnel. preparation of the final protocol. Travel costs/overnight stays will be charged additionally according to expenditure.</p>	DL5101108

COMMISSIONING	
DESIGNATION	PART NO.
<p>VISU type 1 service Creation of topology pages in GridVis®, virtual measurement points (key performance indicators), cost center/power quality reports (EN 50160 / EN 61000-2-4) on customer request. Instruction of operating personnel, preparation of final report. A requirement specification must be provided by the customer. Travel costs/overnight stays will be charged additionally according to expenditure.</p>	DL5101109
<p>VISU type 2 service Creation of a dashboard page in the GridVis® software with about 5 standard widgets, 5 measurement devices and 20 measured values. A requirement specification must be provided by the customer. Travel costs/overnight stays will be charged additionally according to expenditure.</p>	DL5101110
<p>VISU type 3 service Creation of a template page in the GridVis® software with approx. 5 standard widgets and 20 measured values. A requirement specification must be provided by the customer. Travel costs/overnight stays will be charged additionally according to expenditure.</p>	DL5101111
<p>VISU type 4 service Creation of a dashboard overview page in the GridVis® software with linking to up to 10 subpages. Travel costs/overnight stays will be charged additionally according to expenditure.</p>	DL5101112
<p>VISU type 5 service Creation of a Sankey diagram or KPI widget with approx. 20 measured values. Preparation of a requirement specification in consultation with the client. Travel costs/overnight stays will be charged additionally according to expenditure.</p>	DL5101113
<p>VISU type 6 service Creation of custom graphics for the dashboard pages. A requirement specification must be provided by the customer.</p>	DL5101114
<p>Testing of the residual/PE current measurement Testing of residual/PE current measurement by qualified personnel. Compliance with the set limit value must be checked in a live simulation (e.g. test transformer) and the entire alarm/message loop of the Janitza system must be checked for the case of a limit value violation. This must be performed for each individual monitored incoming/outgoing feeder. Results must be logged and submitted to the specialist engineer in hardware and software form (Excel). Minimum report requirement: Project name, distributor name, feeder name, meter name, contractor name, tester name, measured value, message chain function, impressed current, type of test instrument, signature and date, price per res./transformer. Travel costs/overnight stays will be charged according to expenditure.</p>	DL5101125
<p>Adaptation of existing software Adaptation of existing software to the new constellation of the system incl. software and device updates, integration of the new devices in the software, optional creation of an additional database connection, instruction of the operating personnel, preparation of the final report. Travel costs/overnight stays will be charged according to expenditure.</p>	DL5101126
<p>Instruction Project-related instruction in the handling of the software after commissioning, instruction in the functionality of the overall system. Operation of the software with setting options, evaluation displays, visualization, etc. Travel costs/overnight stays will be charged according to expenditure.</p>	DL5101127

COMMISSIONING

DESIGNATION

PART NO.

Programming of UMG 20CM channels

Programming of the parameters of the channels, recording of the data on site, setting of the pulse valencies, implementation in the system, instruction of operating personnel, final protocol creation, without travel to and from site.

DL5101130

Modification of system parameters

Modification of individual system parameters on site, per bus station after commissioning by the service technician within the first 12 months after initial commissioning, e.g.

- Modification of the recording configuration per device
- Modification of nominal values per device
- Modification of current transformer settings per device
- Adjustment of reports per device in the report
- Firmware update per device
- Software update as far as required

Necessary hardware is included on loan as far as required. Modification of parameters via the option of VPN or remote access included. Access is to be ensured and provided by the customer. Alternative: Access via TeamViewer.

Travel costs/overnight stays will be charged additionally according to expenditure.

DL5101133

Creation of a virtual device

Creation of virtual measurement points (devices) in GridVis® with max. 10 input and output measured values.

Travel costs/overnight stays will be charged according to expenditure.

DL5101134



Fig.: Typical commissioning report

CALIBRATION

Calibration additionally includes visual inspection for external damage and damage to the electronics, a comprehensive functional check with automatic testing and updating of the firmware.

After calibration, a high-voltage test (safety test) is performed and a factory calibration protocol is supplied.

CALIBRATION	
DESIGNATION	PART NO.
<p>Calibration type 1: UMG 604 / UMG 604-PRO / UMG 605 / UMG 605-PRO / UMG 96RM / UMG 96-PA / UMG 509 / UMG 509-PRO / UMG 512 / UMG512-PRO</p> <ul style="list-style-type: none"> - Visual inspection for external damage - Open the device and visually check for visible damage to the conductive tracks - Check of the functions with an automatic test - Firmware update - Calibration - High voltage test (safety check) - Delivery of a factory calibration protocol 	DL5101143
<p>Calibration type 2: UMG 103-CBM / UMG 96-S2</p> <ul style="list-style-type: none"> - Visual inspection for external damage - Open the device and visually check for visible damage to the conductive tracks - Check of the functions with an automatic test - Firmware update - Calibration - High voltage test (safety check) - Delivery of a factory calibration protocol 	DL5101144
<p>Calibration type 3: MRG measuring case</p> <ul style="list-style-type: none"> - Visual inspection for external damage - Open the device and visually check for visible damage to the conductive tracks - Check of the functions with an automatic test - Firmware update - Calibration - High voltage test (safety check) - Delivery of a factory calibration protocol 	DL5101145



Calibration Report

Device	
Manufacturer	Janitza electronics GmbH
Object	UM096-PA
Article no.	5232001
Serial no.	43024500
Firmware	3.23
Active Energy Accuracy	Class 0.2S IEC 62053-22:2003 (50/60Hz, ..5A)

Calibration	
Date	August 26, 2021
Engineer	Tajana Befuss

Conditions	
Temperature	24.3°C (+/- 1°C)
Relative humidity	42.0% (+/- 10%)

Equipment	
Manufacturer	Fluke
Model	6100B
Serial no.	273568170
Date of calibration	May 17, 2021
Date of recalibration	May 16, 2022

Result:	PASSED
---------	--------

This document was issued electronically
and is therefore valid without signature.

Janitza®

Test reading Value	Set value	Tolerance	Device	Deviation	Result
Calibration 1 (AC) 50/60Hz/50/60V/50/60A/50/60Hz/50/60Hz					
U _L	50.000V	±0.020V	50.000V	0.000V	pass
U _N	50.000V	±0.020V	50.000V	0.000V	pass
U _H	50.000V	±0.020V	50.000V	0.000V	pass
I _L	200.000A	±0.000A	200.000A	0.000A	pass
I _N	200.000A	±0.000A	200.000A	0.000A	pass
I _H	200.000A	±0.000A	200.000A	0.000A	pass
U _L	100.000V	±0.020V	100.000V	0.000V	pass
U _N	100.000V	±0.020V	100.000V	0.000V	pass
U _H	100.000V	±0.020V	100.000V	0.000V	pass
I _L	400.000A	±0.000A	400.000A	0.000A	pass
I _N	400.000A	±0.000A	400.000A	0.000A	pass
I _H	400.000A	±0.000A	400.000A	0.000A	pass
U _L	150.000V	±0.020V	150.000V	0.000V	pass
U _N	150.000V	±0.020V	150.000V	0.000V	pass
U _H	150.000V	±0.020V	150.000V	0.000V	pass
I _L	600.000A	±0.000A	600.000A	0.000A	pass
I _N	600.000A	±0.000A	600.000A	0.000A	pass
I _H	600.000A	±0.000A	600.000A	0.000A	pass
U _L	200.000V	±0.020V	200.000V	0.000V	pass
U _N	200.000V	±0.020V	200.000V	0.000V	pass
U _H	200.000V	±0.020V	200.000V	0.000V	pass
I _L	800.000A	±0.000A	800.000A	0.000A	pass
I _N	800.000A	±0.000A	800.000A	0.000A	pass
I _H	800.000A	±0.000A	800.000A	0.000A	pass
U _L	250.000V	±0.020V	250.000V	0.000V	pass
U _N	250.000V	±0.020V	250.000V	0.000V	pass
U _H	250.000V	±0.020V	250.000V	0.000V	pass
I _L	1000.000A	±0.000A	1000.000A	0.000A	pass
I _N	1000.000A	±0.000A	1000.000A	0.000A	pass
I _H	1000.000A	±0.000A	1000.000A	0.000A	pass

Fig.: An excerpt from the calibration report

MOBILE RENTAL EQUIPMENT

Typical problems such as defective LED lamps, exploded capacitors, short lifetimes of converters or other electrical consumers, flicker phenomena, manufacturing failures due to voltage dips, etc. are frequently observed in practice. In the case of specific power quality problems where no permanently installed network analyzers are available, we

offer mobile power analyzers of the MRG (UMG) series for temporary measurement and fault analysis. The GridVis® Essentials Power Grid Monitoring Software is provided in the measuring case for use just as with permanently installed UMG measurement devices. This means that no time-consuming training period is necessary.

MOBILE RENTAL EQUIPMENT	
DESIGNATION	PART NO.
<p>Mobile rental MRG 96RM-E RCM Flex energy measurement device</p> <ul style="list-style-type: none"> - Rental device for one week - For measuring, monitoring and checking electrical characteristics in energy distribution systems incl. residual current monitoring - Evaluation with the GridVis® software - Incl. Rogowski coil, part no. 1503604 (Ø 95 mm) or 1503605 (Ø 190 mm). The size of the Rogowski coil must be specified when ordering. - Transformer for residual current monitoring on request. 	<p>5101030</p>
<p>Mobile rental MRG 512 PQ Flex power quality analyzer for network analysis according to EN 50160</p> <ul style="list-style-type: none"> - Rental device for one week - Extensive network data acquisition and recording of faults - Evaluation of critical network parameters (including harmonics, momentary interruptions and residual current monitoring, etc.) and compensation design - Evaluation with the GridVis® software - Incl. Rogowski coil, part no. 1503604 (Ø 95 mm) or 1503605 (Ø 190 mm). The size of the Rogowski coil must be specified when ordering. - Transformer for residual current monitoring on request. 	<p>5101031</p>

Complete package – Mobile power quality analyzer incl. accessories:

- 1 MRG 512-PRO PQ Flex
- 4 Voltage measurement tap-offs with fuses, black (claw gripper)
- 1 Voltage measurement tap-off with fuse, blue (claw gripper)
- 1 Voltage test lead set (brown, black, gray, red, blue)
- 4 Rogowski coils with connecting leads and plug
- 1 Cross patch cable, CAT 5e
- 2 Connection cables with plug for residual current measurement, 3 m (residual current transformers not included in scope of delivery)



Fig.: MRG 512-PRO PQ Flex – Mobile Class A power quality analyzer



Rogowski coil



Voltage measurement tap-offs



RCM measurement cable



PQ QUICK CHECK

The PQ QUICK CHECK is used for quick and easy determination of the power quality status, but does not replace a complete power quality analysis. It includes an evaluation of the power

quality according to EN 61000-2-2 and an individual evaluation of selected measured variables.

PQ QUICK CHECK

DESIGNATION

PART NO.

PQ Quick Check according to EN 61000-2-4/EN50160

Analysis and evaluation of recorded power quality parameters according to the standards EN 50160 and/or EN 61000-2-4 with recommended action in the event of limit value violations or critical parameters. The measurement data to be evaluated are read out by the customer into the GridVis® software and transmitted to Janitza via data transfer.

5101024

Prerequisite: Installed measurement devices of the types UMG 604-PRO, UMG 605-PRO, UMG 509-PRO, UMG 512-PRO. In each case with activated PQ recording and data from at least one contiguous calendar week. Alternatively, the measurement can also be done using a measuring case on a rental basis.

REMOTE MAINTENANCE CONTRACTS ON AN ANNUAL BASIS

Protect yourself. We check your monitoring or energy management system once a year and keep it up to date! Janitza remote maintenance contracts include things like

verification of the accessibility of measurement devices and databases, adjustment of the measurement devices and updates of device firmware and of software.

REMOTE MAINTENANCE CONTRACTS ON AN ANNUAL BASIS

DESIGNATION

PART NO.

Remote maintenance contracts on an annual basis

DL5101060







OTHER SERVICES

FIRMWARE UPDATE

We update your Janitza measurement devices to the latest firmware.

FIRMWARE UPDATE	
DESIGNATION	PART NO.
Firmware update type 1: UMG 604 / UMG 604-PRO / UMG 605 / UMG 605-PRO / UMG 96RM / UMG 96-PA / UMG 509 / UMG 509-PRO / UMG 512 / UMG 512-PRO <ul style="list-style-type: none">- Visual inspection for external damage- Open the device and visually check for visible damage to the conductive tracks- Check of the functions with an automatic test- Firmware update- Calibration- High voltage test (safety check)	DL5101146
Firmware update type 2: UMG 103-CBM / UMG 96-S2 <ul style="list-style-type: none">- Visual inspection for external damage- Open the device and visually check for visible damage to the conductive tracks- Check of the functions with an automatic test- Firmware update- Calibration- High voltage test (safety check)	DL5101147

TEAMVIEWER SESSION

Take advantage of the many years of experience of our engineers and service technicians, solve problems and accomplish new tasks quickly and efficiently via remote sessions. Commissioning and training are also possible via remote maintenance.

TEAMVIEWER SESSION	
DESIGNATION	PART NO.
TeamViewer sessions	DL5101050

INTEGRATION TEST OF GENERIC MODBUS DEVICES

We test for you whether third-party products such as water meters, gas meters and other measurement devices can be integrated via Modbus and are compatible with GridVis®.

INTEGRATION TEST OF GENERIC MODBUS DEVICES	
DESIGNATION	PART NO.
<p>Integration test of generic Modbus devices</p> <p>The customer shall provide the support department of Janitza electronics GmbH with all components required for the integration test free of charge.</p> <p>The components must have the relevant basic configuration with which the component will be used by the customer in the field (Janitza will not adapt the component with regard to changes to the hardware with the manufacturer's own software).</p> <p>Necessary documentation shall be provided.</p> <p>The parameters/measured values which are to be recorded and processed by the GridVis® parameterization/evaluation software must be presented in writing (requirement specification); the following points, among others, must be taken into account here:</p> <p>Modbus address list (with byte order; function code), physical parameter (type; SI unit), number and type of TCP ports, data format, baud rate, parity, serial device address, scalings, update rate of Modbus register addresses.</p>	5101014

PROJECT DEVELOPMENT OF ENERGY MONITORING OR POWER QUALITY MONITORING SYSTEMS

We assist you with the project development of your energy or power quality monitoring system. From the assessment of the actual condition, to the necessary planning, to the selection of the required components.

PROJECT DEVELOPMENT OF ENERGY MONITORING OR POWER QUALITY MONITORING SYSTEMS	
DESIGNATION	PART NO.
<p>Project development of energy monitoring or power quality monitoring systems</p> <p>Discussion and analysis of the actual condition on site, elaboration of a customer-specific solution</p>	5101011



TECHNICAL APPENDIX





374	Standards and directives
388	High availability through 3-in-1 monitoring
426	Continuous measurement
431	Formulary
438	Current transformer
449	Communication
460	Prerequisite and confirmation for commissioning (VBI)

APPLICABLE STANDARDS

Janitza develops, manufactures and tests its measurement devices and products in accordance with internationally applicable standards and directives. The main national and international standards related to our products, solutions and applications are as follows:

GENERAL STANDARDS AND EMC STANDARDS:

- [IEC/EN 60868-0](#): Assessment of flicker severity.
- [IEC/EN 61000-2-2](#): Electromagnetic compatibility (EMC): Environment; Compatibility levels for low-frequency conducted disturbances and signaling in public low-voltage power supply systems.
- [IEC/EN 61000-2-4](#): Electromagnetic compatibility (EMC): Environment; Compatibility levels in industrial plants for low-frequency conducted disturbances.
- [IEC/EN 61000-3-2](#): Limits for harmonic current emissions (equipment current draw ≤ 16 A per phase).
- [IEC/EN 61000-3-3](#): Limits – Limitation of voltage changes, voltage fluctuations and flicker in public low-voltage supply systems, for equipment with rated current < 16 A per phase and not subject to conditional connection.
- [IEC/EN 61000-3-4](#): Electromagnetic compatibility (EMC): Limits – Limitation of Emission of Harmonic Currents in Low-Voltage Power Supply Systems for Equipment with Rated Current Greater Than 16 A.
- [IEC/EN 61000-3-11](#): Electromagnetic compatibility (EMC): Limits – Limitation of voltage changes, voltage fluctuations and flicker in public low-voltage supply systems - Equipment with rated current < 75 A and subject to conditional connection.
- [IEC/EN 61000-3-12](#): Limits for harmonic currents produced by equipment connected to public low-voltage systems with input current > 16 A and ≤ 75 A per phase.
- [IEC/EN 61557-12](#): Electrical safety in low voltage distribution systems up to 1000 V a.c. and 1 500 V d.c. – Equipment for testing, measuring or monitoring of protective measures.

POWER QUALITY STANDARDS:

- **EN 50160:** Voltage characteristics of electricity supplied by public electricity networks.
- **D-A-CH-CZ:** Technical rules for the assessment of grid distortions in Germany, Austria, Switzerland and the Czech Republic.
- **TOR D2:** Technical and organizational rules for operators and users of electrical networks; Part D: Special technical rules; main section D2: Directive for the assessment of grid distortions.
- **IEEE 519:** (Recommended Practices and Requirements for Harmonics Control in Electrical Power Systems) as a joint recommendation by electric utilities and operators to limit the effects of non-linear loads by reducing harmonics.
- **ENGINEERING RECOMMENDATION:** G5/4-1) (planning levels for harmonic voltage distortion to be used in the process for the connection of nonlinear equipment) as a directive of the Energy Networks Association (UK) for limiting the effects of non-linear loads by reducing harmonics at the transfer point (PCC). Valid in Great Britain and Hong Kong.
- **IEEE1159-3 PQDIF:** Recommended Practice for the Transfer of Power Quality Data.
- **ITIC (CBEMA):** The Information Technology Industry Council (ITI) curve represents the resilience of computers / power supplies in terms of the level and duration of voltage disturbances.

STANDARDS FOR POWER QUALITY NETWORK ANALYZERS

- **IEC/EN 61000-4-2:** Testing and measurement techniques – Electrostatic discharge immunity test.
- **IEC/EN 61000-4-3:** Testing and measurement techniques – Radiated, radio-frequency, electromagnetic field immunity test.
- **IEC/EN 61000-4-4:** Testing and measurement techniques – Electrical fast transient/burst immunity test.
- **IEC/EN 61000-4-5:** Testing and measurement techniques – Surge immunity test.
- **IEC/EN 61000-4-6:** Testing and measurement techniques – Immunity to conducted disturbances, induced by radio-frequency fields.

- [IEC/EN 61000-4-7](#): Testing and measurement techniques – General guide on harmonics and interharmonics measurements and instrumentation, for power supply systems and equipment connected thereto.
- [IEC/EN 61000-4-8](#): Testing and measurement techniques – Power frequency magnetic field immunity test.
- [IEC/EN 61000-4-11](#): Testing and measurement techniques – Voltage dips, momentary interruptions and voltage variations immunity tests.
- [IEC/EN 61000-4-15](#): Testing and measurement techniques – Flicker meter, functional and design specifications.
- [IEC/EN 61000-4-30](#): Testing and measurement techniques – Power quality measurement methods.

STANDARDS FOR ENERGY MEASUREMENT DEVICES

- [DIN EN 62053-21](#): Electricity metering equipment. Particular requirements. Part 21: Static meters for AC active energy (classes 1 and 2).
- [DIN EN 62053-22](#): Electricity metering equipment. Particular requirements. Part 22: Static meters for AC active energy (classes 0.2S and 0.5S).
- [DIN EN 62053-23](#): Electricity metering equipment. Particular requirements. Part 23: Static meters for reactive energy (classes 2 and 3).
- [DIN EN 62053-31](#): Electricity metering equipment (a.c.) Part 31: Pulse output devices for electromechanical and electronic meters (two wires only).
- [DIN EN 60529](#): Degrees of protection provided by enclosures (IP code).

STANDARDS FOR ENERGY MANAGEMENT

- [DIN ISO 50001](#): Energy management systems – Requirements with guidance for use
- [DIN EN 16247-1](#): Describes the requirements for an energy audit that enables small and medium-sized enterprises (SMEs) to improve their energy efficiency and reduce energy consumption. Energy audits – Part 1: General requirements; Possibility for small and medium-sized enterprises (SMEs) as defined by the European Commission Recommendation 2003/361/EC to comply with the requirements of the Electricity and Energy Tax Act for the surplus settlement.

ENERGY EFFICIENCY IN LOW-VOLTAGE SYSTEMS

MEASUREMENT ACCURACY ACCORDING TO IEC 60364-8-1:2019+COR1:2019 / VDE 0100-801:2020-10

IEC 60364-8-1:2019+COR1:2019 / VDE 0100-801:2020-10 "Low voltage electrical installation - Part 8-1: Functional aspects - Energy efficiency" defines, among other things, the required measuring accuracy in low-voltage systems.

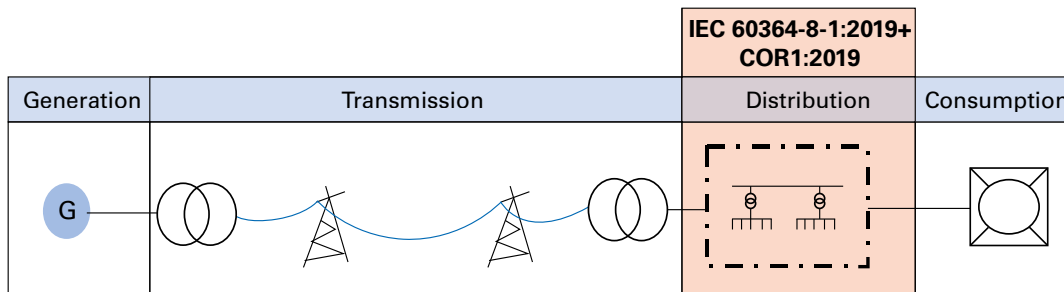

In the context of the construction or retrofitting of a low-voltage switchgear system, this standard combines existing parts of standards and their procedures and criteria with the aim of maximizing energy efficiency. The standard applies to new installations and to annual renovations of old installations estimated to amount to 2-5%.

This part of the standard applies internationally and is derived from the European harmonization directive HD 60364-8-1:2019 as well as the international designation IEC 60364-8-1:2019+COR1:2019.

In Switzerland, the mandatory requirements are set out in the following documents, among others:

- Energy Act (EnG) SR 730.0
- Energy Ordinance (EnV) SR 730.1
- SIA 380/4: Electrical energy in building construction
- SIA 387/4: Electricity in buildings – Lighting
- SIA 2056: Electricity in buildings – Energy and power consumption

The energy efficiency assessment described below, as well as the associated system of points and rating, are to be considered purely informative in the United Kingdom (UK) and Austria.

When designing standard-compliant measurement technology for recording energy data, power quality and other relevant monitoring parameters, the issue of "correct measuring accuracy at the right measurement point" is often the biggest challenge faced in practice. In addition to defining the scope of the measurements, this part of the standard also provides concrete planning specifications.

REQUIREMENTS OVERVIEW FOR POWER MEASUREMENT AND MONITORING

In the table it can be seen that the scope of measurement as well as the measuring accuracy go down from the point of power delivery (PDC) to the final circuits. Thus, a measuring system based on and structured according to the standard has a great impact on the energy efficiency class.

	FEEDER	MAIN DISTRIBUTION	SUB-DISTRIBUTION	DISTRIBUTION FOR FINAL CIRCUITS
Meshes	The total system	Self-contained units (e.g. swimming pool, workshop, office)	Zones and/or applications (e.g. heating of the lobby)	Circuits
Critical range for current accuracy (ratio of expected rated current to actual load current in percent)	Generally medium to high: 30% to 90%	Generally medium: 30% to 70%	Generally low: 20% to 40%	Generally very low: < 20%
Performance characteristics, required for network management	Consumption measurement and monitoring or analysis of the quality of supply	Consumption measurement and monitoring	Consumption measurement and monitoring	Consumption measurement and monitoring
Performance characteristics (measurements) for cost management	Chargeback measurement	Cost allocation	Cost allocation	
	Compensation measurement	Energy usage measurement and optimization	Energy usage measurement and optimization	Energy usage measurement and optimization
	Energy usage measurement and optimization	Efficiency estimate	Efficiency estimate	Energy use forecasts and estimates
	Contract optimization	Contract optimization	Contract optimization	
Accuracy of the overall system for measuring the active energy management	Accuracy class : ≥ 1	Accuracy class : ≥ 2	Accuracy class ≥ 2	Accuracy class ≥ 2

NOTE: Accuracy classes (also called performance classes) are defined in DIN EN 61557-12.
Source: DIN-VDE 0100-801:2020-10, page 32 Table 2

RESPONSIBILITIES FOR SETTING UP, OPERATING AND MAINTAINING AN ENERGY MANAGEMENT SYSTEM ACCORDING TO IEC 60364-8-1:2019+COR1:2019 / VDE 0100-801:2020-10

ACTION	DETAILS	GENERALLY PERFORMED BY
Energy audit and measure	Analysis of data from installed power measurement and monitoring equipment and/or data from measuring equipment that is not permanently installed	Auditor or energy manager
Specification of the basis	Initial selection of equipment, components with more efficient consumption, initial definition of parameters, etc.	Planner and/or installer
Optimization	HVAC control, lighting control, variable speed drives, automatic power factor correction, etc.	Installer/tenant or user, energy manager
Monitor, maintain power capability	Installation of power measurement and monitoring equipment, operation of monitoring services, and electrical energy efficiency analysis, software, etc.	Energy manager/tenant or user
Control & improve	Inspection, maintenance, etc.	Energy manager/tenant or user

Source: DIN-VDE 0100-801:2020-10, page 39 Table 3

ENERGY EFFICIENCY CLASSES ACCORDING TO IEC 60364-8-1:2019+COR1:2019 / VDE 0100-801:2020-10

The standard's point system provides planners, system installers and operators with a yardstick against which to compare the investments and benefits involved in very different measures.

The evaluation criteria for commercial, industrial and infrastructure settings are the same. Only in the case of residential buildings are there isolated deviations in the criteria of the points considered.

In addition to limit values for the various criteria, the standard's gradations enable scalable evaluation options even if not all criteria are considered in the initial situation or a high evaluation point score is achieved.

It makes a structured analysis and evaluation of the system obligatory. The point system provides transparency concerning the quality of the installation as well as of the measuring system.

Use of this standardized methodology makes it possible to determine how additional initial investments in commercial, industrial, and residential buildings will affect energy consumption and how quickly payback occurs. IEC 60364-8-1:2019+COR1:2019 also directs attention to the life cycle of a system as well as its energy efficiency and continuous availability.

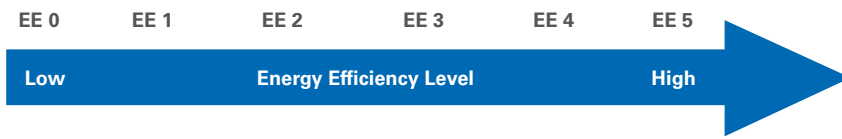

In light of the energy efficiency that is desired, measurement technology is an indispensable focus of the standard: The actual efficiency of the system must be verifiable and transparent.

In addition, measures to increase energy efficiency can only be optimally determined on the basis of adequate, continuously recorded measurement data as well as their analysis and evaluation.

The standard includes 23 evaluation criteria from the categories "Initial Installation," "Energy Management," "Maintenance of the Power Capability," "Performance Monitoring" and a "Bonus" category.

A different number of points can be achieved per criterion. The sum of the points gives the efficiency class of the electrical system: from EE 0, the worst, to EE 5 for systems with the highest efficiency.

The parameters recorded include power factor ($\cos \phi$), the efficiency of the transformer(s), the voltage drop, the harmonics content, etc.

These metrics must be recorded and evaluated according to the point system. Aspects such as the number of applications measured, load management coverage, and duration of load disconnection have an impact on the efficiency class of the electrical system.

Example: Evaluation of the energy efficiency of an electrical installation in an industrial building

PARAMETERS	TITLE	STANDARD SUBPOINT	POINTS
INITIAL INSTALLATION			
II 01	Determination of the energy consumption	B.3.2.2.1	6
II 02	Positioning of the main feed and total consumption	B.3.2.2.2	4
II 03	Voltage drop	B.3.2.2.3	6
II 04	Efficiency of the transformer(s)	B.3.2.2.4	2
II 05	Efficiency of permanently installed electrical consumables	B.3.2.2.5	2
ENERGY MANAGEMENT			
EM 01	Zones	B.3.2.3.1	1
EM 02	Applications	B.3.2.3.2	2
EM 03	Load management	B.3.2.3.3	2
EM 04	Meshes	B.3.2.3.4	5
EM 05	Measurement per application	B.3.2.3.5	3
EM 06	Presence detection per zone / room	B.3.2.3.6	4
EM 07	Introduction of an energy management system	B.3.2.3.7	6
EM 08	HVAC control	B.3.2.3.8	4
EM 09	Lighting control	B.3.2.3.9	1
MAINTENANCE OF POWER CAPABILITY			
MA 01	Introduction of a life cycle methodology	B.3.2.4.1	8
MA 02	Frequency of power capability review	B.3.2.4.2	3
MA 03	Data management	B.3.2.4.3	4
MA 04	Power capability of the transformer(s) (operating point)	B.3.2.4.4	1
MA 05	Continuous monitoring of systems with high energy consumption	B.3.2.4.5	0
PERFORMANCE MONITORING			
PM01	Power factor (cos phi)	B.3.2.5.1	4
PM02	Harmonics content	B.3.2.5.2	3
Bonus			
BS 01	Renewable energies	B.3.2.6.2	3
BS02	Energy storage	B.3.2.6.3	2
Total points			76

Source: DIN-VDE 0100-801:2020-10, page 56 / 57 Table B.2

Detailed information on the allocation and calculation of the above-mentioned points of the individual criteria as well as the associated evaluation parameters and limit values are defined in the standard.

The total number of points in the example above is 76 points.

Overall evaluation of the efficiency class of the electrical system

EFFICIENCY CLASS OF THE ELECTRICAL SYSTEM	TOTAL POINTS			
	FOR RESIDENTIAL PURPOSES	FOR INDUSTRIAL PURPOSES	FOR COMMERCIAL PURPOSES	FOR INFRASTRUCTURAL PURPOSES
Class EE 0	from 0 to 14	from 0 to 19	from 0 to 18	from 0 to 18
Class EE 1	from 15 to 30	from 20 to 38	from 19 to 36	from 19 to 36
Class EE 2	from 31 to 49	from 39 to 63	from 37 to 60	from 37 to 59
Class EE 3	from 50 to 69	from 64 to 88	from 61 to 84	from 60 to 83
Class EE 4	from 70 to 89	from 89 to 113	from 85 to 108	from 84 to 106
Class EE 5	90 or more	114 or more	109 or more	107 or more

Source: DIN-VDE 0100-801:2020-10, page 56 Table B.1

In the previous example of an electrical system in an industrial building, the 76 points awarded result in the energy efficiency class EE3.

If the expected energy efficiency class of the electrical system is not achieved or if individual criteria are changed in the meantime, an energy efficiency action plan must be defined in line with the standard and the process of continuous improvement. Positive changes in terms of improvements are also recorded with the action plan.

Furthermore, the relevant part of the standard defines the measurements for verification of the energy efficiency plan in paragraph "8.3.4.4 Measurement for verification of the energy efficiency action plan" in excerpts as follows:

"The effectiveness of the measures taken under the energy efficiency action plan must be verified. This provides proof of success or evidence of deviations.

For each individual aspect of the energy efficiency action plan, the energy savings achieved in each part of the system or operating equipment, as applicable, must be measured separately or determined by an equally effective method."

Source: DIN-VDE 0100-801:2020-10, page 35/36

MID – MEASURING INSTRUMENTS DIRECTIVE

The abbreviation MID stands for "**Measuring Instruments Directive**" and can be equated with the German term "**Messgeräte-Richtlinie**". This refers to "Directive 2004/22/EC of the European Parliament and of the Council of 31 March 2004 on measuring instruments".

WHAT IS THE OBJECTIVE OF THE MID?

- EU-wide regulation of market access for the measurement devices concerned
 - Creation of a harmonized European market for measurement devices
 - Uniform approval procedure for all EU states and some other states
 - One-time, uniform test for approval
 - Uniform and transnational regulation for initial validation
- Uniform product identification
- Reduction of validation and testing costs
 - Initial validation is performed by means of a manufacturer's declaration of conformity
 - No separate calibration test or calibration fee
 - Shorter delivery times
- Level playing field due to high product quality requirements
 - Additional requirements for accuracy in the low load range
 - Higher requirements for EMC
 - Better reflection of the current state of measurement technology

WHAT DOES THE MID REGULATE?

The MID concerns 10 types of measurement devices (electricity meters, water meters, gas meters ...) in the field of legal metrology and defines basic as well as measurement device-specific requirements.

The previous initial validation by the weights and measures authority or by a state-approved testing body is replaced by a conformity assessment procedure in which the involvement of a named body selected by the manufacturer is mandatory.

It makes the manufacturer responsible for the initial placing on the market and the initial putting into service within the EU. After that, national law applies.

To do this, the manufacturer must select a conformity assessment procedure specified in the MID by means of which he ensures, under the supervision of a notified body, that the measurement device comply with the MID. Only then may the measurement device covered by the MID be placed on the market or put into service. The meter must be accompanied by a declaration of conformity. This is often printed in the operating manual.

After placing the measurement device on the market or putting it into service, the responsibility for consistently achieving correct measuring results is transferred to the user.

MARKING OF THE DEVICES

The sequence for MID marking is prescribed and must correspond to the following example:

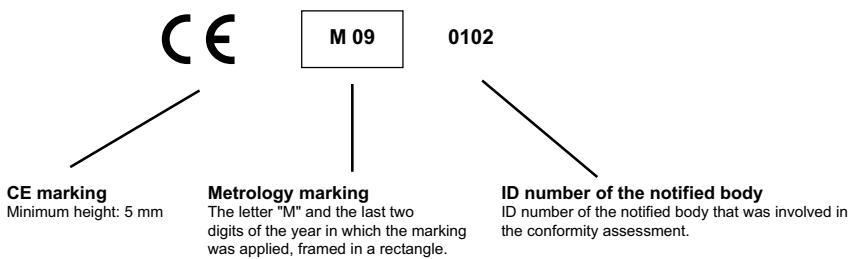

RECALIBRATION?

The MID has no effect on recalibration under calibration law. In Germany, measurement devices whose conformity has been established in a prescribed conformity assessment procedure and which are correctly marked are considered to be initially validated.

The user of the measurement device is still responsible for the timely application for recalibration.

The calibration validity period is specified in the national calibration regulations. In Germany, this is a period of eight years after MID marking for electronic electricity meters.

Further information for Germany can be found at the following link: www.eichamt.de

DEGREE OF PROTECTION TO EN 60529

PROTECTION OF ELECTRICAL OPERATING EQUIPMENT

According to EN 60529, electrical operating equipment (e.g. luminaires, LED modules and operating devices) must have a specific degree of protection depending on its exposure to foreign bodies and water. The degrees of protection are also called IP codes. The abbreviation IP stands for "International Protection" or "Ingress Protection".

THE IP CODE ACCORDING TO EN 60529

The degree of protection provided by an enclosure is verified using standardized test methods. The IP code is used to classify this degree of protection. This consists of the two letters IP and a two-digit code number. The degrees of protection refer exclusively to protection against contact with and ingress of solid foreign bodies and dust (indicated by the first digit of the IP code) and against harmful ingress of water (indicated by the second digit of the IP code). The degree of protection does not say anything about protection against external influences. In addition, the degrees of protection must also not be confused with the electrical protection classes, which refer to protective measures to prevent electric shock.

Important note: In addition to the degree of protection, external influences and conditions must always be taken into account as well.

CODE LETTERS		
IP	International Protection (Ingress Protection)	
CODE DIGIT 1	PROTECTION AGAINST FOREIGN BODIES	PROTECTION AGAINST CONTACT
0	No protection	No protection
1	Protected against solid foreign bodies with a diameter from 50 mm	Protected against access with the back of the hand
2	Protected against solid foreign bodies with a diameter from 12.5 mm	Protected against access with a finger
3	Protected against solid foreign bodies with a diameter from 2.5 mm	Protected against access with a tool
4	Protected against solid foreign bodies with a diameter from 1.0 mm	Protected against access with a wire
5	Protected against dust in a harmful quantity	Complete protection against contact
6	Dustproof	Complete protection against contact
CODE DIGIT 2	PROTECTION AGAINST WATER	
0	No protection	
1	Protected against vertically falling dripping water	
2	Protected against falling dripping water when the housing is tilted up to 15°	
3	Protected against falling spraying water up to 60° against the vertical	
4	Protected against splashing water from all sides	
5	Protected against water jets (nozzle) from any angle	
6	Protected against powerful water jets	
7	Protected against brief immersion	
8	Protected against continuous immersion	

OVERVOLTAGE CATEGORIES

Electrical distribution systems and consumers are becoming increasingly complex. This also increases the probability of transient overvoltages. Power electronics modules in particular (e.g. frequency converters, leading and trailing phase-angle controls, PWM-controlled power switches) generate temporary voltage peaks in conjunction with inductive loads, which can be considerably higher than the respective nominal voltage. To ensure safety for the user, four overvoltage categories (CAT I to CAT IV) have been defined in DIN VDE 0110 / EN 60664.

The measuring category specifies the permissible areas of application for measuring and testing devices for electrical operating equipment and systems (e.g. voltage testers, multimeters, VDE test devices) for use in the area of low-voltage networks.

DEFINED CATEGORIES AND INTENDED USES IN IEC 61010-1:

THE FOLLOWING CATEGORIES AND INTENDED USES ARE DEFINED IN IEC 61010-1:	
CAT I	Measurements on circuits that do not have a direct connection to the mains (battery operation), e.g. devices of protection class 3 (operation with protective low voltage), battery-operated devices, car electrics
CAT II	Measurement on circuits that have a direct connection to the low-voltage mains by means of a plug, e.g. household appliances, portable electrical appliances
CAT III	Measurements within the building installation (stationary consumers with a non-pluggable connection, distribution connection, permanently installed devices in the distribution board), e.g. sub distribution
CAT IV	Measurements at the source of the low-voltage installation (meter, main connection, primary overcurrent protection), e.g. meter, low-voltage overhead line, house connection box

The categories are also divided into the voltage levels of 300 V / 600 V / 1,000 V.

The category is of particular importance for safety during measurements, since low-impedance circuits have higher short-circuit currents and / or disturbances in the form of load switching and other transient overvoltages must be withstood by the measurement device without endangering the user through electric shocks, fire, sparking or explosion. Due to the low impedance of the public power supply network, short-circuit currents are highest at the house infeed. Within a house system, the maximum short-circuit currents are reduced by the series resistors in the system. Technically, compliance with the category is ensured, among other things, by the contact safety of plugs and sockets, insulation, sufficient air clearance and creepage paths, strain reliefs and kink protection of cables as well as adequate cable cross sections.

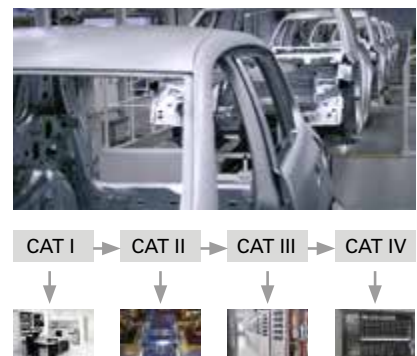

Fig.: Pictorial representation of the CAT categories

FROM PRACTICAL EXPERIENCE

In our estimation and experience, many users are not sufficiently aware of this issue. The question of overvoltage category may have the result for some applications that instead of a UMG 604-PRO rated at 300 V CAT-III, you may have to switch to a UMG 509-PRO with the overvoltage category of 600 V CATIII, i.e. instead of a 4,000 V surge voltage rating, a 50% higher rated surge voltage of 6,000 V is reached. However, it may also result in the relocation of the measurement point. This means additional safety for man and machine!

The combination of the CAT category and the defined voltage level results in the rated surge voltage.

VOLTAGE CONDUCTOR TO NEUTRAL CONDUCTOR, DERIVED FROM NOMINAL AL- TERNATING OR NOMINAL DIRECT VOLT- AGES UP TO AND INCLUDING V	NOMINAL VOLTAGES CURRENTLY IN USE WORLDWIDE				RATED SURGE VOLTAGE FOR OPERATING EQUIPMENT			
	THREE-PHASE 4-CONDUCTOR SYSTEMS WITH GROUNDED NEU- TRAL CONDUCTOR	THREE-PHASE 3-CONDUCTOR SYSTEMS, UN- GROUNDED	SINGLE-PHASE 2-CONDUCTOR SYSTEMS, ALTER- NATING OR DIRECT VOLTAGE	SINGLE-PHASE 3-CONDUCTOR SYSTEMS, ALTER- NATING OR DIRECT VOLTAGE	OVERVOLTAGE CATEGORIES			
	V	V	V	V	I	II	III	IV
150	120 / 208* 127 / 220	115, 120, 127	100** 110, 220	100 – 200** 101 – 220 120 – 240	800	1,500	2,500	4,000
300	220 / 380, 230 / 400 240 / 415, 260 / 440 277 / 480	200**, 220, 230, 240, 260, 277, 347, 380, 400, 415, 440	220	220 – 400	1,500	2,500	4,000	6,000
600	347 / 600, 380 / 660 400 / 690, 417 / 720	500	480	480 – 960	2,500	4,000	6,000	8,000

* Customary in the United States of America and Canada.

** Customary in Japan.

HIGH AVAILABILITY THROUGH 3-IN-1 MONITORING

Whereas years ago a momentary voltage dip caused just a flicker in the lighting, today it can paralyze entire businesses. That is why close monitoring is essential. The disturbances can also be home-made – in the literal sense of the word. In the best case, defects can even be detected and eliminated as they arise. There is no need for the user to work with a variety of instruments to monitor the entire infrastructure. A single modern monitoring system can do this conveniently and reliably.

Highly automated manufacturing plants, data centers but also plants with continuous processes (e.g. food, cable factories, paper production) require a reliable power supply – often even high availability, i.e. an availability of at least 99.9%. The many servers, monitors, storage media and network components now in use can tolerate almost no voltage dips or other power quality deviations from the standard (e.g. EN 50160). However, electrical energy must be available "cleanly" and reliably not only for information and communications technology, but also for infrastructure applications, such as climate control, fire prevention, EMC, safety technology, lighting, elevators and drives.

3-IN-1 MONITORING FOR SAFETY AND EFFICIENCY

It is not surprising that in all these applications, the demand for a reliable power supply is even more important than the ubiquitous question of energy efficiency. Continuous monitoring with appropriately integrated measurement technology for energy management, power quality and residual current monitoring accommodates this, because it serves both objectives. At the same time, residual current monitoring improves preventive fire protection. However, in practice, collecting, evaluating and documenting all of the measurement data is a complex task. It must also all be done very quickly if, for example, an insulation fault that is just developing is to be detected before the system fails.

This is why Janitza, as a specialist for digital measurement technology and monitoring systems in the field of power supply, has developed its new series UMG 512-PRO, UMG 96RM-E and UMG 20CM for monitoring on 3 levels (see the section "Monitoring solutions in practice"). Together with the GridVis® software and the integrated alarm management, these series combine solutions for three areas in a shared system environment with only one measurement device per measurement point:

3-in-1 monitoring

- Energy management according to ISO 50001 (recording of V, A, Hz, kWh, kW, kVAh, kvar, ...)
- Power quality monitoring (harmonics, flicker, voltage dips, transients, ...)
- Residual current monitoring (RCM)

The bundling of these three different functions in a single measurement device offers the great advantage that assembly and installation as well as the rest of the infrastructure (current transformers, communication lines and facilities, database, software, analysis tools and reporting software ...) are needed only once. Furthermore, all data is centrally recorded in a database and can be conveniently processed with only one software program. This not only saves direct costs in purchasing, but also simplifies integration: There is no need for interfaces between different systems – after all, it's just one system. This also reduces the effort required for training measures and familiarization, which in turn increases acceptance among the responsible electrical specialists.

NOTIFICATION BEFORE FAILURE

A significant advantage of this integrated data acquisition is its speed and the comprehensive overview of all data it affords. This makes it possible to detect disturbances that a single system would only perceive in part or not at all. This allows the user to respond before fuses or residual current devices (RCDs) shut down affected systems or socket power circuits. This applies in particular to gradually rising residual currents (e.g. caused by insulation faults), excessive operating currents or other overloads of system parts or consumers (Fig. 1).

Another source of faults are massive grid distortions or resonance phenomena caused by a growing number of non-linear electrical loads. If irregular network variables such as excessive harmonics or residual currents are detected in good time, repair measures can be initiated before a device fails, thus avoiding or at least allowing planning or a reduction of downtime.

RCM, THE UNIVERSAL TOOL: GREATER SAFETY, HIGHER SYSTEM AVAILABILITY, LOWER FIRE HAZARD

As mentioned above, RCM is playing an increasingly important role for highly available power supplies, which can now be found in almost all market segments. Especially continuous processes and particularly sensitive applications such as data centers, hospitals or semiconductor factories rely on RCM. RCM measurement also offers a good alternative wherever insulation resistance measurements and residual current devices cannot be implemented due to local or operational conditions. The "predictive" monitoring described also helps to reduce alarms, as required for alarm management in accordance with EEMUA 191 or NAMUR NA 102, for example.



Fig. 1: Alert before switching off – An objective of residual current monitoring

But RCM can do even more, namely reduce the risk of fire! A residual current triggered by defective insulation can be insidious. The current level is determined by the power of the feeding network, the insulation fault resistance and the grounding resistance. If the current flow is sufficiently high (in the case of a saturated ground fault or a correspondingly low-resistance short-circuit), the upstream protective device will disconnect the electrical consumer from the mains. However, if the residual current is too small, the protective device will not trip. If the induced error power exceeds a value of approx. 60 watts (approx. 261 mA at 230 V), there is risk of fire. Residual current monitoring thus also serves to prevent fires. The next section shows how RCM works in detail.

RCM – HOW IT WORKS

The basic operation of the residual current principle is shown in Fig. 2. The phase and the neutral conductor of the feeder to be protected are led through the summation current transformer, while the protective conductor is excluded. For a better overview, the figure shows a highly simplified circuit. In practice, all three phases and the neutral conductor run through the summation current transformer. When the system is in the fault-free state, the summation current is zero or close to zero (within the tolerance range), so that the current induced in the secondary circuit is also zero or close to zero. If, on the other hand, a residual current flows to ground in the event of a fault, the current imbalance causes a current in the secondary circuit which is detected and evaluated by the RCM measurement device (Fig. 3).

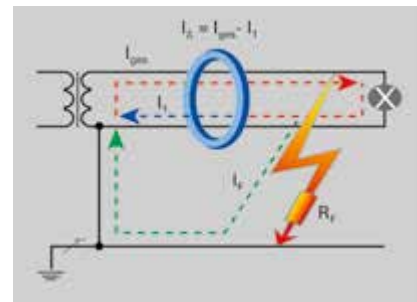

Fig. 2: Principle of residual current measurement

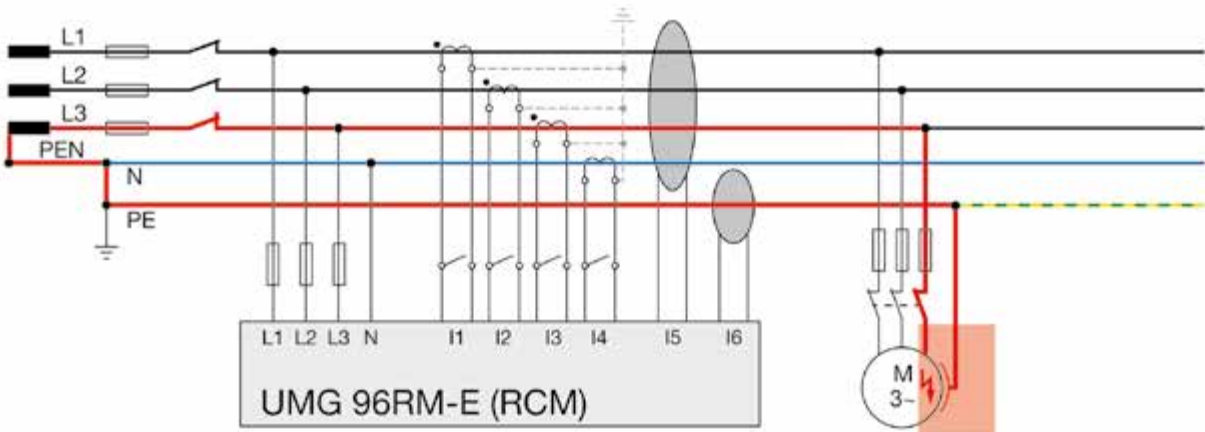

Fig. 3: Faulty motor insulation leads to a ground fault and fault current to the PE conductor

Modern RCM devices allow different limit value settings (Fig. 4). A static limit value has the disadvantage that it is either too large at partial load or too small at full load, i.e. there is either insufficient protection or false alarms occur, which can have a negative effect on the attention of the monitoring personnel in the long term. For this reason, it is recommended to use RCM measurement devices with dynamic limit value adaptation. In this case, the residual current limit value is specified on the basis of the current load conditions and is thus optimally adapted to the load in question (Fig. 5).

By parametrizing (i.e. defining the typical residual current in the "GOOD" state) the system while it is new and using continuous monitoring, all changes in the system state from the time of commissioning can be detected. This can also be used to detect creeping residual currents.

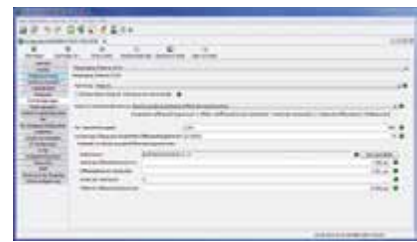

Fig. 4: Extensive configuration options for RCM limit value formation (e.g. dynamic limit value formation) in the GridVis® software

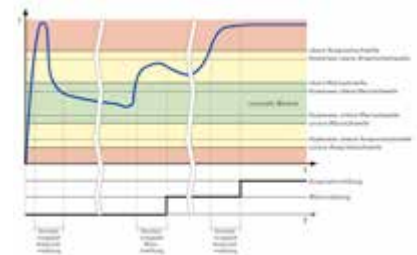

Fig. 5: Parameters of residual and operating current monitoring

NEW TECHNOLOGY, NEW SOURCES OF ERROR

An example of "modern sources of error" are collapsing polypropylene phase shift capacitors. These are used to compensate for reactive currents, such as those that can be caused by three-phase motors. Paradoxically, a fault thus arises from a facility that is actually intended to improve the energy supply. With these capacitors, overload or overtemperature often causes the PP windings to melt. The melted material then causes a high-impedance ground fault. Such ground faults cannot be disconnected by conventional protective measures (HRC fuse, circuit breaker). The continuous residual current usually leads to a saturated short-circuit in the medium term and can then represent a significant fire or safety hazard under certain circumstances (Fig. 6). Residual current measurement detects such faults and allows rapid countermeasures. This helps avoid costly and dangerous equipment failures.

Errors often occur already during installation, such as impermissible connections between the N and PE conductors. Sometimes the two are simply reversed. Figure 7 shows a typical connection error, which can easily result in a residual current of 5000 mA. With RCM, such errors are immediately detected during the installation phase and reported via the alarm management system.



Fig. 6: Destroyed PP reactive power compensation capacitor: A creeping high-impedance ground fault has led to the complete melting of the capacitor and a localized fire.

Another, rather novel source of errors is a large number of single-phase loads, such as the switching power supplies of servers in data centers or PCs in office buildings. They cause a high proportion of 3rd harmonics. These harmonic components have the major disadvantage that they are superimposed on the neutral conductor instead of being canceled out by the transformer windings. This can result in N conductor overloads. Integrated measurement devices, such as the UMG 96RM-E, allow comprehensive monitoring of all phases and can thus report excessive neutral conductor currents in good time.

In this context, the safety regulations of the VdS association of insurers (Verband der Sachversicherer) for electrical installations up to 1000 volts should also be mentioned:

"VdS 2046 : 2010-06 (11)

3.2.4 In order to increase safety in electrical systems in which numerous non-linear consumer devices are operated (such as frequency converters, controls by means of phase angles, e.g. in lighting systems), the current in the neutral conductor must be measured regularly, e.g. once a year, but also after significant changes in the electrical system or in the type and number of electrical consumers. If the safety of the installation is endangered by excessive harmonic currents, measures must be taken to protect against harmonics in accordance with the publication "Low-interference electrical installation" (VdS 2349)."

THE CHALLENGE OF HIGH AVAILABILITY

EDP technology in itself already places high demands on power supplies. Especially critical, however, are applications in which data loss simply must not occur. BITKOM, for example, writes as follows in its guide "Operationally Secure Data Centers": "Data centers pose the highest availability requirements. Accordingly, the energy supply must be ensured on a sustainable basis. It is almost self-evident that the power supply of the data center itself and all areas in the same building to which data cables run must be designed as a TN-S system. "An absolute necessity for safe operation is the continuous self-monitoring of a "clean" TN-S system and the connection of the messages to a permanently manned point, e.g. to the control center. The electrically qualified person can thus recognize the need for action due to corresponding messages and prevent damage by taking specific service measures."

The Janitza solution allows realization of the safety criterion "RCM, residual current monitoring" of an EMC-optimized TN-S system of this nature (Figure 8).



Fig. 7: Here N and PE have been reversed

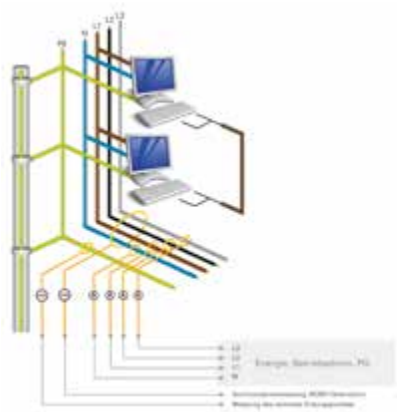

Fig. 8: Continuous 3-in-1 monitoring (EnMs-RCM-PQ) of an EMC-optimized TN-S system

REDUCE INSPECTION COSTS WITH RCM

Periodic inspections, such as those required by BGV A3 – Electrical Installations and Equipment, are time-consuming and therefore expensive. RCM monitoring systems can reduce these inspection costs while still providing increased safety. Stationary electrical systems and equipment are considered to be permanently monitored if they are continuously maintained by electrically qualified persons and tested by means of metrological measures during operation (e.g. monitoring of insulation resistance). Continuous RCM measurement enables monitoring systems to ensure the required continuous testing. It is particularly worth mentioning that RCM makes the cost-intensive measurement of insulation resistances at least partially superfluous, and continuous testing of the insulation properties takes place. For conventional insulation measurement, the fixed installation or consumer must be switched off and the neutral conductor disconnected. In addition, there is a risk that sensitive electronic components may be damaged by the high test voltage of the insulation measurement. The test severity and scope can be reduced by continuous monitoring. However, this must be defined on an application-specific basis. Agreements with the operator, if necessary also experts and/or the employers' liability insurance association are mandatory for this!

It should be explicitly mentioned at this point that the following work must be carried out despite continuous RCM measurement:

- Visual inspection for externally visible defects
- Protective measures and shutdown conditions
- Loop resistances and continuity testing of protective conductors
- Functional test

THE VdS ASSOCIATION OF INSURERS REQUIRES RCM

The VdS comments on the subject of harmonics / installation of the power supply system as follows:

"In power supply systems with PEN conductors, operational currents which can cause damage flow in the entire grounding and equipotential bonding system (see section 3.3). For new electrical systems that are to be installed, TN systems should therefore be planned as TN-S systems. For existing TN-C systems, conversion to a TN-S system is recommended. TN-S systems are to be implemented starting from the feeder (transfer point), if possible.

In order to ensure the functionality of a TN-S system in the long term (no conductor short-circuit between N and PE conductors, no reversing of N and PE conductors), it must be monitored by a residual current monitoring device (RCM).

When the set response value is reached, a perceptible visual and audible error message must be given so that the defects can be rectified immediately. For the message to be successful, it should be posted to a manned location as needed. If this type of connection is waived, a forced disconnection of the faulty circuit is mandatory ..."

Elsewhere, in the safety regulations for electrical installations up to 1000 volts, the VdS prescribes:

"VdS 2046 : 2010-06 (11)

3.2 Maintaining proper condition

3.2.3 In order to ensure safety in electrical installations in the long term, if insulation resistance measurements cannot be carried out due to local or operational circumstances, substitute measures must be taken. Such measures are described in the publication "Protection in the case of insulation faults" (VdS 2349)."

An adequate substitute measure here is permanent RCM monitoring!

ENERGY MEASUREMENT AND STANDARD ELECTRICAL PARAMETERS

RCM plays a dominant role in installation monitoring using the Janitza system. Nevertheless, other points should not remain unmentioned: In addition to a secure energy supply, energy efficiency is playing an increasingly important role. A milestone was created in this respect with the adoption of the ISO 50001 standard. ISO 50001 is the normative basis for the introduction of an energy management system – whereby the focus here is on the term management system. Following other management systems such as ISO 9001 or ISO 14001, this is a methodology for setting goals, implementing them systematically, and eliminating the factor of chance as far as possible. The term "goal" here is to be understood more in terms of "the means is the goal". The resolution of the Council of IT Commissioners of February 2013 can be cited as an example of this: (Page 2, Resolution No. 2013/2, Point 2)

"The IT Council continues to strive for a high percentage of continuous measurement by the end of 2013 and asks departments to continue to promote the use of permanent measurement devices, taking into account the principle of cost-effectiveness." With its broad selection of UMG measurement devices and electricity meters, Janitza makes it possible to acquire and record standard electrical parameters as well as power and energy consumption data (Fig. 9).

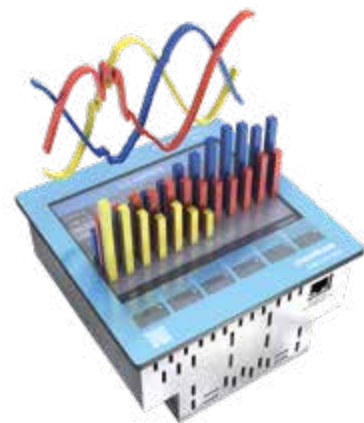

Fig. 9: The "3-in-1" measurement device from Janitza: UMG 512-PRO

POWER QUALITY MONITORING

RCM and the requirements of Bitkom and the VdS association of insurers were covered in the first two parts. The last point of 3-in-1 monitoring is power quality. Reliable operation of modern plants and systems always requires high supply reliability and good power quality. But in modern power supplies, from industrial networks to office buildings, a wide range of single- and three-phase, non-linear loads are used. This includes lighting technology, such as light controllers for spotlights or energy-saving lamps, numerous frequency converters for heating, air-conditioning and ventilation systems, frequency converters for automation technology or elevators, as well as the entire IT infrastructure with the regulated switching power supplies typically employed. In many places today, you can also find inverters for photovoltaic (PV) systems and uninterruptible power supplies (UPS).

All these non-linear electrical loads cause greater or smaller grid distortions which impact the originally "clean" sinusoidal shape. This also distorts the current and voltage waveforms accordingly (Figure 10, and Figure 11).

The burden placed on the grid infrastructure caused by the described electrical and electronic loads with grid distortions has increased significantly in recent years. Depending on the type of generation plant and operating equipment (grid feeder with converter, generator), grid stiffness at the connection point and the relative size of the non-linear loads, different grid distortions and influences can occur. For secured power supplies in data centers, the power quality must comply with EN 61000-2-4 (Class 1).

With a wide range of UMG measurement devices, Janitza makes it possible to record and analyze the various power quality parameters. Standardized power quality reports in the GridVis® software (e.g. for EN 50160, EN 61000-2-4 and ITIC: "CBEMA curve") allow reports for common standards to be generated virtually at the push of a button.

MONITORING SOLUTIONS IN PRACTICE

The goal of 3-in-1 monitoring solutions is integrated measurement of energy, power quality and RCM and requires the measurement of all conductors (L1, L2, L3, N) + CGP (Central Grounding Point) + RCM with a single measurement device.

A powerful measurement device with 6 measured current inputs for 3-in-1 measurement is the UMG 96RM-E for intermediate distribution boards, or for main nodes and CGP, the UMG 512-PRO from Janitza. The IP-based measurement devices can be easily integrated into existing communication networks via Ethernet. Numerous IP protocols, the onboard homepage and the SNMP protocol facilitate the work of administrators.

In complex electrical installations with a large number of points to be monitored, the 20-channel UMG 20CM is the ideal solution. These measurement devices can detect, continuously record and analyze fault, residual and operating currents in any combination via the associated measuring current transformers (e.g. CT-6-20).

Special residual current transformers with practical special designs also allow cost-effective retrofitting in existing systems without having to switch off electrical consumers.

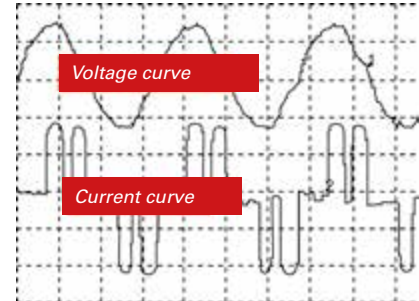

Fig. 10: Grid distortions through frequency converters

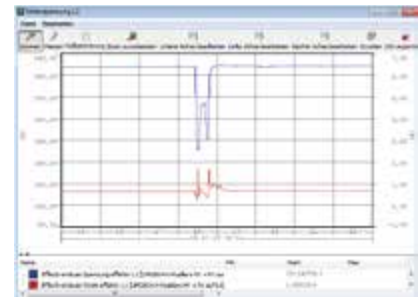

Fig. 11: Critical voltage dip with production standstill

ALARMS IN THE RIGHT PLACE

Alarms must not go unheard. An acoustic signal from the switchboard cabinet in the low-voltage HRC distribution is of little use to those in the control room. Integration of the RCM measurement devices in the GridVis® software with its extensive alarm management reporting options ensures that messages quickly reach the right recipient. With any desired escalation level and a logbook function, the monitoring control center has all the tools it needs for efficient monitoring. This enables the responsible electrically qualified person to detect and evaluate any increases in residual current as quickly as possible and initiate maintenance measures as needed.

VAGRANT CURRENTS DISTURB THE EMC

Connections between N and PE conductors lead to "vagrant" operating currents being distributed via the PE system, data lines and all metal parts of the building. Because these currents are not balanced, they generate electromagnetic fields. The consequences are many types of disturbances in the electrical systems, EDP networks and piping systems of the building installation. Figure 12 illustrates how the operating current is divided at the PEN bridge and can flow back over several paths, meaning that the sum of the supply and return current is no longer 0. This can cause the following disturbances:

- Changes in the operating behavior of frequency-dependent components (e.g. capacitors consume more current)
- Disturbances of data transmissions due to magnetic and inductive influences
- Transmission of lightning influences into the electrical system
- Corrosion on metallic pipes
- Influence on persons

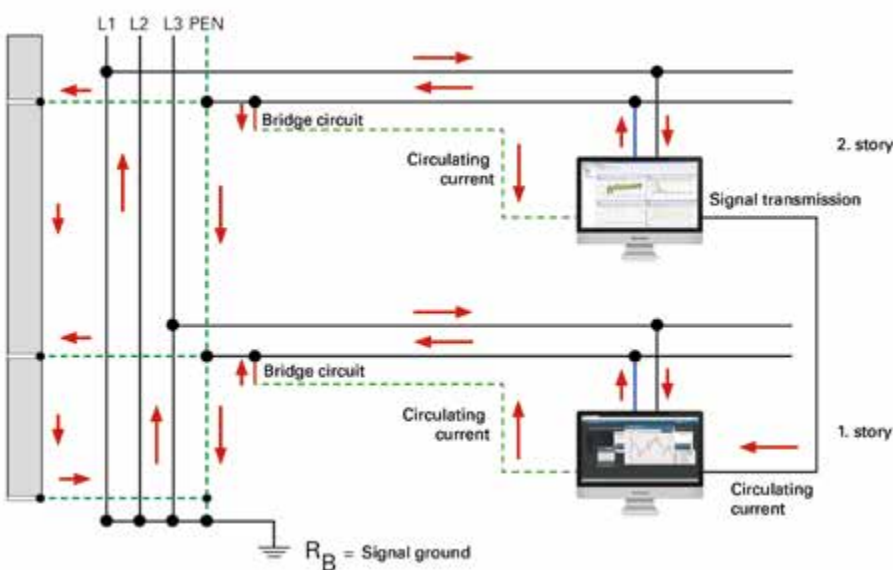

Fig. 12: Operating currents on grounding systems

Supply and return conductors, including in distributions, should be arranged close together to minimize magnetic fields. At each node of a circuit, the sum of the currents must be zero to avoid residual currents. In addition, the sub distribution or the circuit should be monitored with an RCM. The UMG 96RM-E is very well suited for monitoring subdistribution panels or larger consumers.

Individual circuits, in which no residual current devices can be used due to operational reasons, can be monitored with the UMG 20CM. A reporting RCM in combination with on-site specialist personnel creates maximum, alternative safety.

NEUTRAL CONDUCTOR AND CGP

The neutral conductor (operating current return conductor) today has become the most important conductor. It must be treated like a phase conductor. To keep the grounding system "clean", the current-carrying N conductor must be placed far from the PE conductor. There must be no galvanic operating currents flowing via the grounding system, as these would cause inductive coupling. These measures must be taken all the way to the feeding source.

In the TN-S system, the N conductor must be connected to the grounding system only once, at the so-called CGP (central grounding point from N to PE), at a suitable point and this must be monitored. Undesirable insulation faults or galvanic connections between N and PE are immediately detected by monitoring the CGP. Deviations are reported in a timely manner and time dependencies are analyzed.

Whether the TN-S system is functioning without errors can be checked with the UMG 512-PRO, for example. It allows a broad overview of power quality and EMC. This means even the initiation phase of a ground fault can be recorded and analyzed. The phase current then increases in parallel with the CGP current. The current at the CGP must always be considered in relation to the total power of the TN-S system. This means that, on the one hand, operational leakage currents are tolerated, but abnormal deviations at the CGP are reported by the RCM.

SUMMARY AND OUTLOOK

Increasingly high demands are being placed on future power supplies because power failures cause high costs and immense aggravation! Continuous RCM monitoring to safeguard highly available power supplies with high EMC requirements, but also for preventive fire protection, is gaining increasing acceptance. The goal here is RCM monitoring of the power supply at all four levels (feeder [PCC], main distributions [transformer feeders], subdistribution panels, individual loads [e.g. server cabinets]).

ENERGY (DATA) MANAGEMENT

WHY ISO 50001 IS NOT EVERYTHING

Again and again we are confronted with the question: "You do sell energy management systems, don't you?!" The answer, which is always the same, is: "Yes and no." Our product portfolio includes components, software and solutions for the collection and analysis of energy-related data and thus provides the basis for a number of possible tasks and objectives, and thus also for an energy management system.

ISO 50001

ISO 50001 is the normative basis for the introduction of an energy management system. The focus here is on the term management system. Following other management systems such as ISO 9001 or ISO 14001, this is a methodology for setting goals, implementing them systematically, and eliminating the factor of chance as far as possible. Here, the term "goal" is to be understood more in terms of "the means is the goal".

The PDCA or Plan-Do-Check-Act system pursues a CIP (continuous improvement process) that gradually examines processes and procedures for their optimization potential and defines measures and responsibilities as well as the resources and time periods required for this. ISO 50001 is similar in structure to ISO 9001 or even ISO 14001 and can therefore be easily integrated into existing management systems, which significantly simplifies the effort required for implementation.

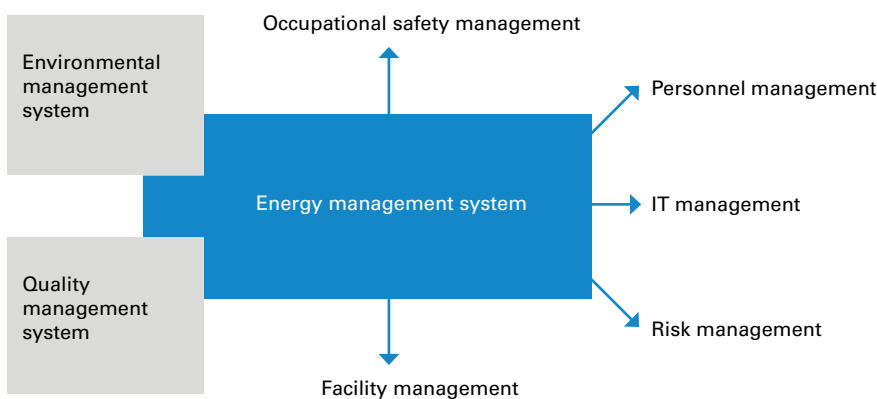

The word "check" contained in the PDCA procedure also immediately indicates its relevance for the topic of measurement data acquisition and evaluation, or put differently: energy data management. Without measurement, no target/actual comparison, no benchmark is possible. Although ISO 50001 does not contain any clear specifications regarding the scope and frequency of energy measurements, practical experience shows that without a minimum of measurement technology for continuous recording – at least for all major consumers – potentials can only be ascertained to a limited extent and savings targets can therefore not be achieved comprehensively enough. Customers who have achieved their certification with a minimum of measurement effort recognize the benefit of more extensive measurement across as many consumers as possible during the ongoing PDCA process.

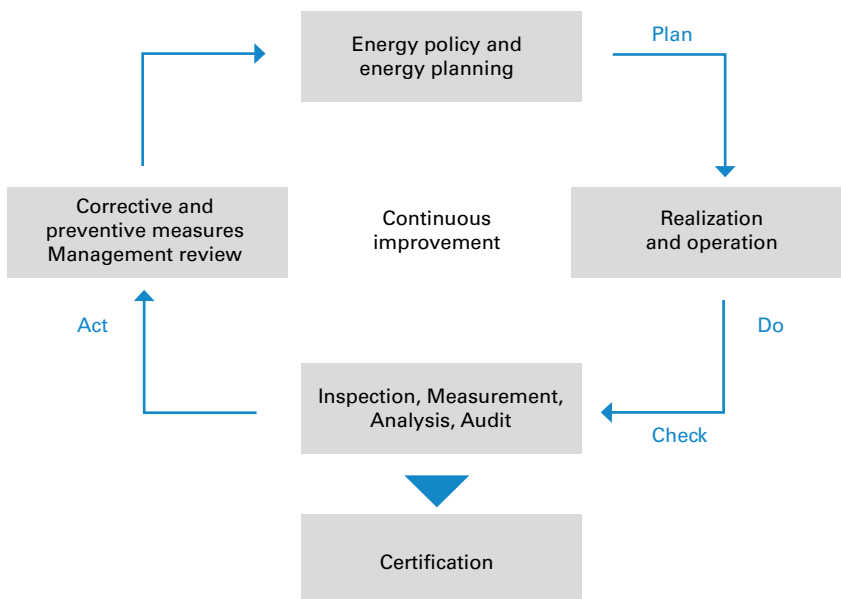

Our measuring systems are scalable and grow with the customer's requirements. Existing structures can be adopted just as, conversely, our measurement devices can be integrated into existing systems.

Frequently, in connection with the introduction of ISO 50001, questions are asked about the validation and subsequent calibration of the measurement devices. The standard prescribes neither. Measurement devices in the form of calibrated meters are not prescribed, nor is recalibration of the measurement devices at regular intervals. This would, in fact, involve an unreasonable amount of work, since digital measurement devices cannot typically be calibrated when in the installed state.

The company to be certified must only ensure the comparability of the measurements in the different periods and document the verification, by whatever means. For our universal measurement devices, this means that when used as intended (ambient temperature!), the measuring accuracy after years is still greater than that of conventional meters in their as delivered condition. For practical purposes, we

recommend a random comparison or parallel measurement of the power and work values with a high-quality measurement device such as our MRG 605 or MRG 511 measuring case via the current transformer measuring terminal strips we offer.

For information on this topic in Germany and how to apply, please contact the Federal Office for Economic Affairs and Export Control: www.bafa.de/bafa/en/indexhtml

Who actually needs ISO 50001?

(German legal situation in 2013)

EEG apportionment Sec. 40 ff – EEG apportionment reduction

Under certain conditions, companies are entitled to apply for a reduction of the EEG apportionment:

- The company must be part of the manufacturing industry
- The share of electricity costs must be at least 14% of gross value added
- The annual consumption must be at least 1 GWh per site
- **As of an annual consumption of 10 GWh, certification according to ISO 50001 is required to obtain the reduction**

The regulation is intended to ensure the international competitiveness of energy-intensive companies. Due to the increase in the share of renewable energy producers, the EEG apportionment will probably continue to rise sharply, which would indeed put energy-intensive companies at a significant competitive disadvantage. Despite all the half-truths spread in the media on this subject, practice shows that the lion's share of all companies that have applied for and received approval for the EEG reduction do actually belong to the sector of energy-intensive companies and are in international competition. A much larger proportion of companies with high electricity consumption of > 1 GWh per year are already disqualified due to the 14% value-added hurdle during the approval process.

ELECTRICITY TAX ACT SEC. 10 – SURPLUS SETTLEMENT

Under certain conditions, companies in the manufacturing sector can benefit from what is known as the surplus settlement under Section 10 of the Electricity Tax Act (StromStG). In this context, the tax burden remaining after application of Sec. 9b StromStG can be waived or refunded to the company. This "relief in special cases" (i.e. surplus settlement) is only granted to the extent that the tax burden exceeds € 1,000 in a calendar year (excess/base amount). The amount of relief depends on the difference between the electricity tax which exceeds the base amount, and the (fictional) relief resulting from the fact that pension insurance contributions have fallen since the introduction of the electricity tax (in the case of general pension insurance, from 20.3% before the introduction of the electricity tax to currently 18.9%; with an employer contribution of 50%, this meant a reduction of 0.7% for employers in 2013; the "difference"). A maximum

of 90% of this difference is waived as relief, refunded or credited. This calculation formula results in companies with high electricity consumption and few employees (subject to pension insurance) benefiting in particular from the surplus settlement.

Since 2013, proof of an ISO 50001-certified energy management system has been required for large companies to obtain the surplus settlement. For small and medium-sized enterprises (SMEs), an energy audit in accordance with DIN EN 16247-1 is sufficient.

Applications and information can be obtained from the responsible main customs offices: www.zoll.de/EN/Home/home_node.html

FROM PRACTICAL EXPERIENCE:

Managing Director F. to Operations Manager A.: "How much electricity do we actually use?" Operations Manager A.: "Not entirely sure, but definitely a lot!" Managing Director F.: "Make sure that changes!" Operations Manager A. to plant electrician M.: "We need to reduce our electricity costs. Take care of it." One year later. Managing Director F. to Operations Manager A.: "The electricity costs are as just as high as ever. How can that be?" Operations Manager A.: "I'll have to ask M." Operations Manager A. to plant electrician M.: "We're still paying insane electricity bills. How can that be? I told you you needed to take care of that!" Plant electrician M.: "Yeah, boss, but the controller canceled the money for new drives, then my colleague was sick for four weeks and, as you know, day-to-day business is really hectic, the phone rings all the time and everyone wants something from you!"

... with ISO 50001 this would not have happened!

WHO ELSE NEEDS AN ENERGY MANAGEMENT SYSTEM (ENMS)?

Basically, every company with a certain energy consumption and a large number of different consumers and processes can benefit from the introduction of an

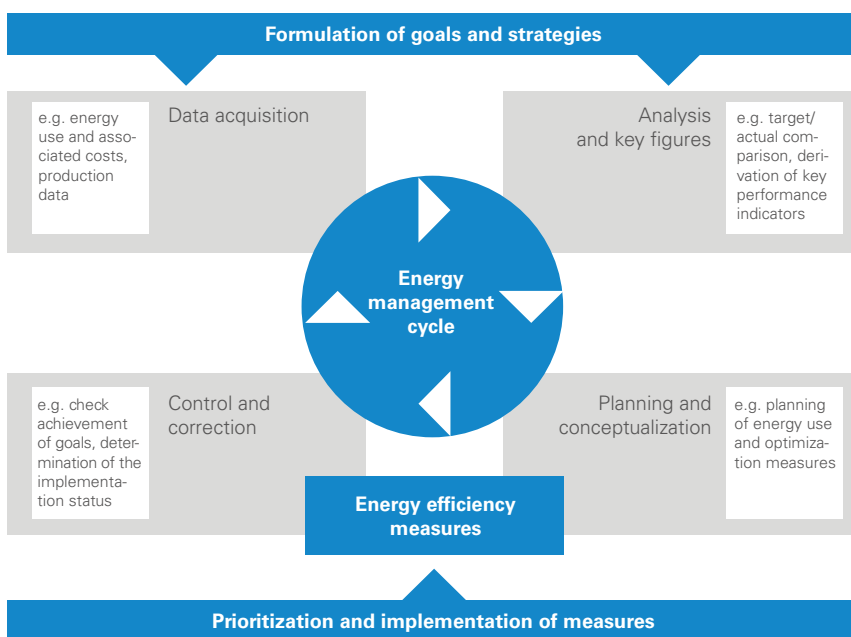

Energy management represents a closed control loop with the objective of continuous improvement.

energy management system according to ISO 50001. The underlying system ensures sustainable, targeted measures to reduce energy costs. In addition, an EnMS in accordance with ISO 50001 will also gain in importance in the future as a marketing tool for presenting a green and environmentally conscious corporate philosophy.

Now, it must be conceded to companies which operate professionally that a certified management system does not necessarily have to be established in the company in order to sustainably reduce energy costs. In addition, there are countless companies that lack the legal prerequisites for EEG apportionment reduction or the surplus settlement and for whom ISO 50001 is therefor not a mandatory issue. Nevertheless, energy costs are high.

Those who create the necessary transparency with an energy data management system from Janitza are laying the foundation for sustainable, energy-conscious economic management.

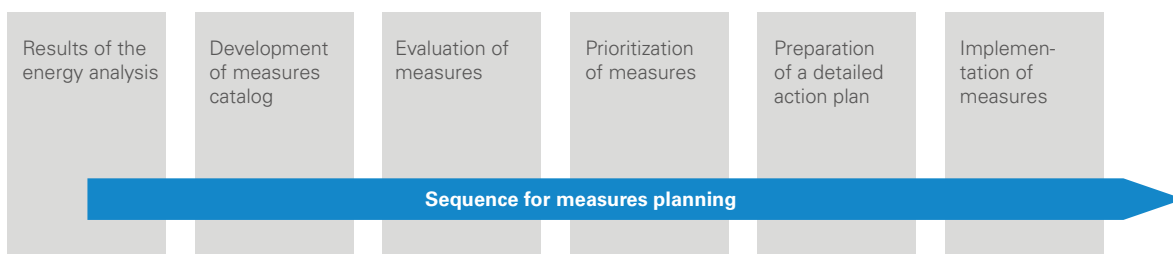

PEAK LOAD MANAGEMENT AND NETWORK CHARGES

Another important aspect of cost reduction, which can also be pursued with an energy data management system, is the control and reduction of peak loads. Electric utilities calculate network charges based on a highest load measured within a quarter of an hour. This value may then remain valid for the entire billing year. However, it could be that this value simply arose arbitrarily or by chance. Frequently, the actual "troublemakers" causing peak loads cannot be identified at first glance.

Only those who create transparency in the load profiles of their main consumers have the opportunity to actively counteract this. This can be done by selectively switching off consumers, by connecting the company's own generators or, where this is not possible from a process engineering point of view, by means of time-delayed switch-on processes or down-regulation of non-essential process operations.

Another, but often unknown, aspect is that, according to Section 19 (1) StromNEV – Special Forms of Network Usage, utilities must offer their customers a discounted monthly demand rate if, due to special circumstances, the peak load that was measured once is significantly higher than what is normal for the company.

A good overview of all subjects pertaining to ISO 50001, energy efficiency and subsidy opportunities for the German market can be found on the following Internet pages:

Federal Office for Economic Affairs and Export Control: http://www.bafa.de/EN/Home/home_node.html

At the main customs offices: www.zoll.de/EN/Home/home_node.html

DENA – German Energy Agency: www.dena.de/en.html

The DENA list of certified energy consultants: www.energie-effizienz-experten.de

Credit institute for reconstruction: www.kfw.de

LOAD MANAGEMENT AND OPTIMIZATION OF MANUFACTURING PROCESSES

It is not only the peak load that increases electricity costs. Studies in large manufacturing plants have shown that, depending on the process, electricity consumption amounting to several gigawatt hours per site is sometimes generated annually during shift-free periods and idle phases alone! A fine-meshed network of measurement points within the production structures in conjunction with modern PLC controllers and production control systems enables automated optimization in realtime and in high quality. Janitza encoders are ideally suited for this task due to their open communication interfaces, high sampling rate and measuring accuracy.

LOAD MANAGEMENT AND PURCHASING ELECTRICITY

Any one who knows their load profiles and buys electricity on the spot market can of course do so with pinpoint accuracy and a precise knowledge of their volatile demand based on the load profiles.

SUBSIDIES AND PUBLIC FUNDS

The government provides extensive assistance for the implementation of measures and for investment in equipment and operating resources to increase energy efficiency. From low-interest loans to actual investment subsidies and covering the costs for (sometimes mandatory) certified energy consultants. The list is long, and the offers are constantly changing.

A comprehensive overview of all subsidy measures:

www.foerderdatenbank.de

Federal Ministry for the Environment, Nature Conservation and Nuclear Safety:

www.bmu.de/energieeffizienz

NRW energy agency:

www.energie-im-unternehmen.de

IHK, TÜV and DEKRA on their country-specific websites

OVERVIEW OF POWER QUALITY PARAMETERS

In modern power supplies, ranging from industrial networks to office buildings, a wide range of single- and three-phase, non-linear loads are used. This includes lighting technology, such as light controllers for spotlights or energy-saving lamps, numerous frequency converters for heating, air-conditioning and ventilation systems, frequency converters for automation technology or elevators, as well as the entire IT infrastructure with the regulated switching power supplies typically employed. In many places today, you can also find inverters for photovoltaic (PV) systems and uninterruptible power supplies (UPS). All these non-linear electrical loads cause greater or smaller grid distortions which impact the originally "clean" sinusoidal shape. This also distorts the current and voltage waveforms accordingly.

Reliable operation of modern plants and systems always requires high supply reliability and good power quality.

The burden placed on the grid infrastructure caused by electrical and electronic loads with grid distortions has increased significantly in recent years. Depending on the type of generation plant and operating equipment (grid feeder with converter, generator), grid stiffness at the connection point and the relative size of the non-linear loads, different grid distortions and influences occur.

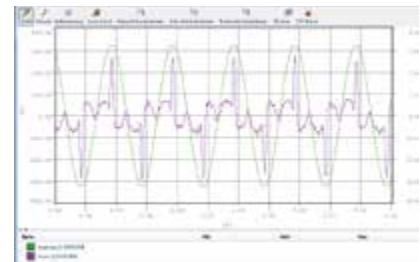

Fig.: Distorted current shape due to consumer electronics

The following power quality parameters must be given special attention:

- Harmonics current
- Current and voltage unbalance
- Rapid voltage changes – transients
- Voltage dips and momentary overvoltages
- Voltage interruptions (MIs – momentary interruptions)
- Flicker
- Phase shift and reactive power

HARMONICS CURRENT

The ever-increasing number of non-linear loads in our power grids is causing increasing "grid pollution". This is also referred to as grid distortion, and is similar to the pollution that is familiar in terms of the environment with respect to water and air. Ideally, generators produce a purely sinusoidal current at the output terminals. This sinusoidal voltage waveform is considered the ideal AC voltage waveform, and any deviation from it is called a grid disturbance.

More and more consumers are drawing non-sinusoidal current from the grid. The FFT Fast Fourier Transform of these "polluted" current waveforms yields a wide range of harmonic frequencies – commonly referred to as harmonics current.

Harmonics current is harmful, sometimes even dangerous, for electrical networks, and connected consumers suffer from it, similar to the way in which polluted water is unhealthy for our human body. This results in overload, reduced service life and possibly even early failures of electrical and electronic consumers.

Harmonic loads are the main cause of invisible power quality problems involving enormous costs for servicing and investments for the replacement of defective equipment. Unacceptably high grid distortions and the resulting poor power quality can thus lead to problems in manufacturing processes and even to production downtimes.

Harmonics are currents or voltages whose frequency is above the 50/60 Hz fundamental frequency and which are a whole-number multiple of the fundamental frequency. The harmonics currents have no share in the active power, they only pose a thermal burden for the network. Since harmonic currents flow in addition to the "active" sinusoidal oscillation, they cause electrical losses within the electrical installation, which can lead to thermal overload. Additional losses in the consumer also lead to heating up or overheating and thus to a reduction in service life.

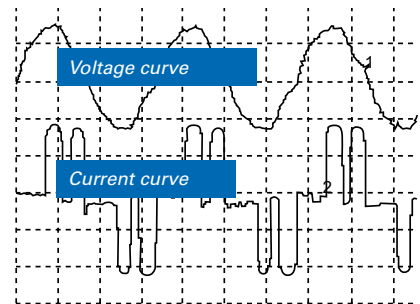

Fig.: Grid distortions due to frequency converters

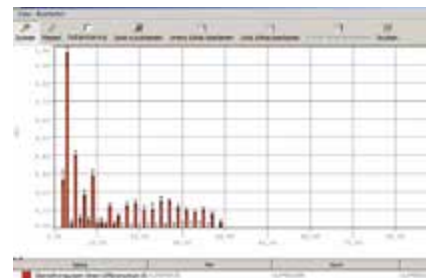

Fig.: Harmonics analysis (FFT)

LIMIT VALUES OF INDIVIDUAL HARMONIC VOLTAGES AT THE TRANSFER POINT UP TO THE 25TH ORDER AS A PERCENTAGE OF THE FUNDAMENTAL U_1

ODD HARMONICS				EVEN HARMONICS	
NO MULTIPLES OF 3		MULTIPLES OF 3			
ORDER h	RELATIVE VOLTAGE AMPLITUDE U_h	ORDER h	RELATIVE VOLTAGE AMPLITUDE U_h	ORDER h	RELATIVE VOLTAGE AMPLITUDE U_h
5	6.0%	3	5.0%	2	2.0%
7	5.0%	9	1.5%	4	1.0%
11	3.5%	15	0.5%	6 to 24	0.5%
13	3.0%	21	0.5%		
17	2.0%				
19	1.5%				
23	1.5%				
25	1.5%				

The assessment of the harmonic load usually takes place at the connection or transfer point from the public power grid of the respective energy supplier (electric utility). In English-speaking countries, but also increasingly in German-speaking countries, this is referred to as the Point of Common Coupling (PCC). However, under certain circumstances, it may also be important to determine and analyze the harmonic load caused by individual items of equipment or groups of equipment in order to identify internal power quality problems and possibly their originators.

The following parameters are used to assess the harmonic load:

TOTAL HARMONIC DISTORTION (THD)

Total Harmonic Distortion (THD) is a specification to quantify the magnitude of the signal components that result from nonlinear distortion of an electrical signal. This means it indicates the ratio of the RMS value of all harmonics currents to the RMS value of the fundamental oscillation. The THD value is used in low, medium and high voltage systems. Usually THD_i is used for the current distortion and THD_u for distortion of the voltage.



Fig.: Capacitors destroyed by harmonics current

THE VOLTAGE DISTORTION FACTOR

- M = Ordinal number of the harmonic
- M = 50 (UMG 605-PRO, UMG 512-PRO)
- Fundamental oscillation fund is n = 1

$$THD_U = \frac{1}{|U_{fund}|} \sqrt{\sum_{n=2}^M |U_{n.Harm}|^2}$$

THE CURRENT DISTORTION FACTOR

- M = Ordinal number of the harmonic
- M = 50 (UMG 605-PRO, UMG 512-PRO)
- Fundamental oscillation fund is n = 1

$$THD_I = \frac{1}{|I_{fund}|} \sqrt{\sum_{n=2}^M |I_{n.Harm}|^2}$$

TOTAL DEMAND DISTORTION (TDD)

Especially in North America, the term TDD is also almost always found in connection with the problem of harmonics. This is a specification that refers to the THD_i , but here the harmonics content is referenced against the fundamental oscillation component of the current rating. The TDD thus gives the ratio between the current harmonics (analogous to the THD_i) and the effective current value occurring at a given interval under **full load conditions**. Typical intervals are 15 or 30 minutes.

TDD (I)

- TDD indicates the ratio between the current harmonics (THD_i) and the effective current value at full load.
- I_L = Full load current
- M = 50 (UMG 605-PRO, UMG 512-PRO)

$$TDD = \frac{1}{I_L} \sqrt{\sum_{n=2}^M I_n^2} \times 100\%$$

CURRENT / VOLTAGE UNBALANCE

Symmetry in a three-phase system is said to exist when the three phase-to-phase voltages and currents are equal and 120° out of phase with each other.

Unbalance occurs when one or both conditions are not met. In most cases, the cause for unbalance lies in the loads.

In high and medium voltage systems, loads are usually three-phase and balanced, although large single or two-phase loads may also be present (e.g., mains frequency induction furnaces, resistance furnaces, etc.). In the low-voltage network, the electrical loads are often also single-phase (e.g. PCs, consumer electronics, lighting systems, etc.), and the associated load circuits should be distributed as evenly as possible over the three phase conductors within the electrical cabling system. Depending on the balancing of the single-phase loads, the network is operated more or less balanced or unbalanced.

The compatibility level for the degree of unbalance in steady-state operation of the voltage caused by all network loads is specified at $\leq 2\%$. For some individual consumer installations, the resulting degree of unbalance is restricted to $= 0.7\%$, averaged over 10 minutes.

VOLTAGE UNBALANCE RESULTS IN THE FOLLOWING EFFECTS:

- Increased current load and losses in the network.
- For the same load power, phase currents can reach 2 to 3 times the value, and losses can reach 2 to 6 times the value. Lines and transformers can then only be loaded to half or one third of their rated power.
- Increased losses and vibration torques in electrical machines.
- The field set up by the negative sequence component of currents runs counter to the direction of rotation of the rotor and induces currents in it, which leads to increased thermal stress.
- Rectifiers and inverters react to an unbalanced supply voltage with uncharacteristic harmonic currents.
- In three-phase systems with a Y connection, a current flows through the neutral conductor.

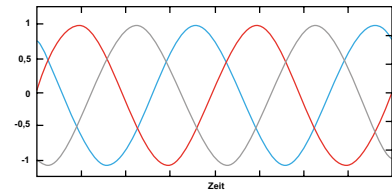

Fig.: Symmetry

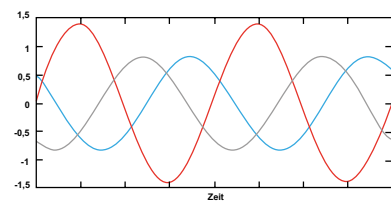

Fig.: Unbalance

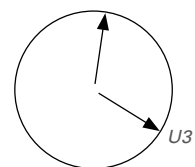

Fig.: Representation of unbalance in a phasor diagram

TRANSIENTS

Transients are pulsed electrical phenomena which exist for just a very brief period of time. Usually these are high frequency, steep signals in the form of transient oscillations.

Reliable detection of transient processes in the electrical power supply network is very important to prevent damage. Constant changes in the electrical supply network due to switching operations and faults result in continually changing, new network conditions to which the entire system must adapt. Normally, transient equalizing currents and equalizing voltages occur here. Reliable decision criteria are required to allow assessment of whether the transient processes are the result of an intentional or unintentional network change and whether these are still within the tolerance range.

Depending on the energy influx (e.g. lightning strike), high transient overvoltages can lead to insulation damage and destruction of equipment and machinery.

High-quality, digital power quality analyzers with a high sampling frequency are required to detect and record transients.

PRACTICAL EXAMPLE:

The connection of unchoked capacitors often causes high transient currents, even with unproblematic network configurations. Choking has a strong damping effect in this case and can thus protect against avoidable problems that are difficult to predict. Alternatively, special capacitor contactors with precharging resistors should be used.

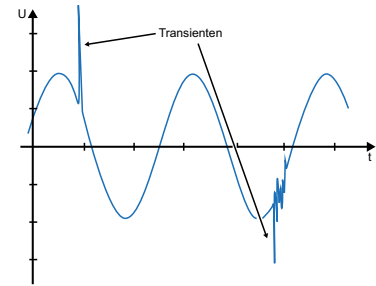

Fig.: Transients

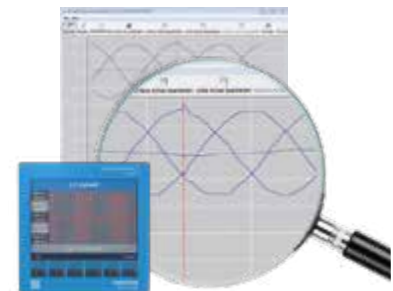

Fig.: With the UMG 512-PRO, transients can be displayed directly on the measurement device.



VOLTAGE DIPS AND INTERRUPTIONS

Voltage dips can lead to major complications, such as the failure of production processes and quality problems. Such dips occur far more often than interruptions. The economic impact of voltage dips is severely underestimated time and again.

WHAT IS A VOLTAGE DIP?

According to the European Standard EN 50160, a voltage dip is understood to be a sudden drop in the RMS voltage value to a value between 90% and 5% of the specified value, followed by a direct recovery of the correct voltage. The duration of the voltage dip is between half a period (10 ms) and one minute.

If the RMS value of the voltage does not fall below 90% of the set value, this is considered a normal operating condition. If the voltage drops below 5% of the set value, this is an interruption.

A voltage dip is therefore not to be confused with an interruption. An interruption occurs, for example, after a fuse has tripped (typ. 300 ms). The mains power failure propagates through the rest of the distribution network in the form of a voltage dip.

The figure illustrates the difference between a dip, a momentary interruption and an undervoltage.



Fig.: Example: Voltage dips due to bird droppings

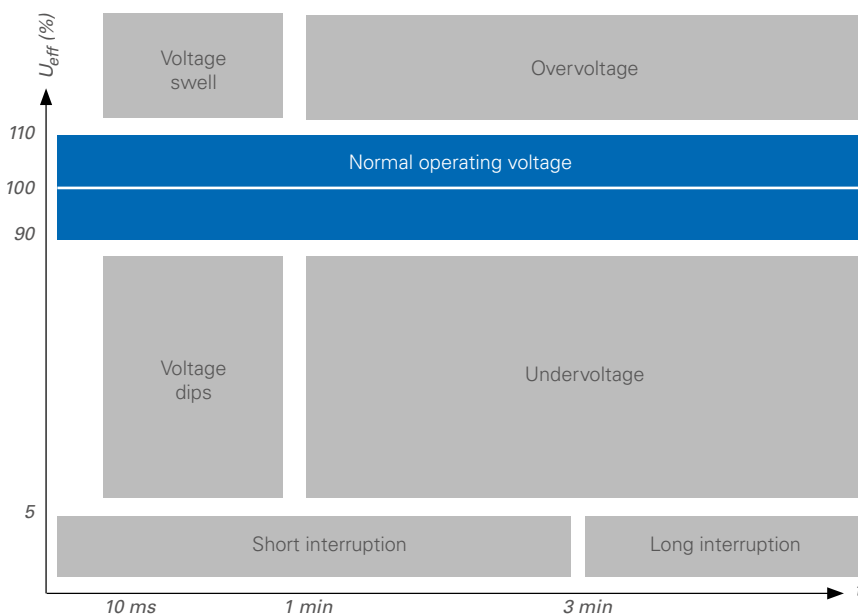

VOLTAGE FLUCTUATIONS ARE CAUSED BY:

- Short circuits
- Large loads switching on and off
- Drives starting (larger loads)
- Load changes for drives
- Pulsed power (vibratory package controls, thermostatic controls)
- Arc furnaces
- Welding machines
- Capacitors switching on

Voltage dips can cause computer systems, PLC systems, relays and frequency converters to fail. In critical processes, even a single voltage dip can cause high costs, and continuous processes are particularly affected. Examples include injection molding, extrusion, printing processes or the processing of foods such as milk, beer or soft drinks.

THE COSTS CAUSED BY A VOLTAGE DIP CONSIST OF:

- Lost profits due to production downtime
- Costs for making up for lost production time
- Costs for late delivery of products
- Costs for lost raw materials
- Costs for damage to machines, equipment and dies
- Maintenance and personnel costs

Sometimes processes run in unmanned areas where voltage dips are not immediately noticed. In this case, for example, an injection molding machine can come to a standstill unnoticed. If this is only discovered later on, great damage has already been done. Customers receive the products too late and the plastic in the machine has hardened.

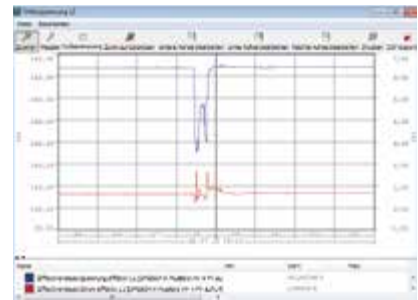

Fig.: Critical voltage dip with production standstill

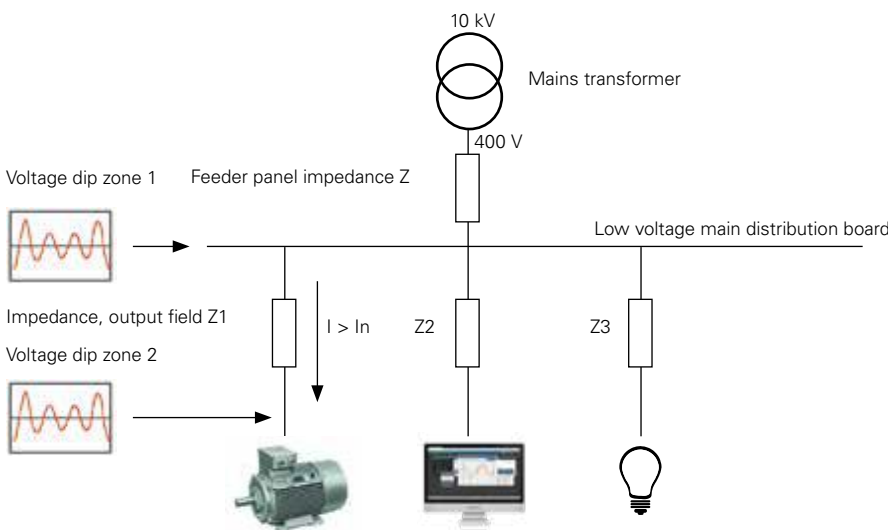

Fig.: The start-up of motors can lead to a voltage dip

FLICKER

Flicker refers to the subjective impression of luminance changes or the impression of discontinuity of visual perceptions caused by light stimuli with temporal fluctuations of the luminance or spectral distribution. From a technical perspective, voltage fluctuations cause luminance changes in lamps that can cause a visually perceptible phenomenon known as flicker. Above a certain threshold, the appearance of flicker can have a disturbing effect. The disturbing effect of voltage fluctuations depends on the repetition rate and the waveform of the voltage changes. The strength of short-term flicker and long-term flicker are defined as measures of the disturbing effect.

Voltage fluctuations caused by individual devices (on the low-voltage network) are permissible if the resulting flicker disturbance factor does not exceed 1. A long-term flicker disturbance factor averaged from twelve values must not exceed the value of 0.65. The simplest method for evaluating this is to use the = 1 p.u. curve. P.u. stands for "unit of perception" and is the maximum tolerance level for the sensitivity of the human eye to the perception of light fluctuations. The combined effect of all disturbance sources must not exceed the value = 1 p.u.

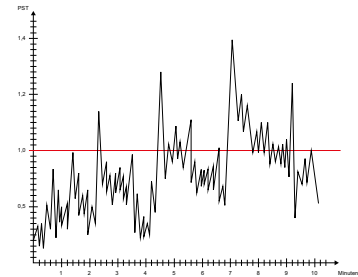

Fig.: Course over time of short-time flicker (PST)



Fig.: A practical example of flicker: A gravel plant

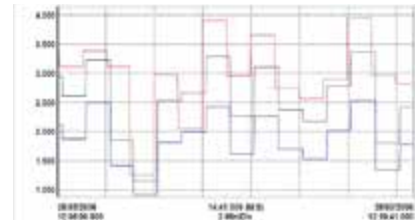

Fig.: Course of flicker over time

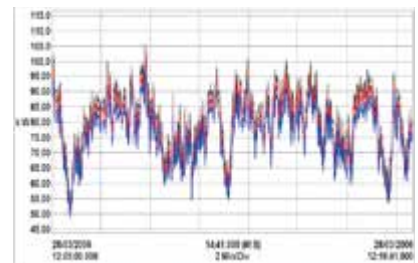

Fig.: Active power curve as a function of the quantity and consistency of the material

PHASE SHIFT AND REACTIVE POWER

Reactive power is required to generate the electromagnetic fields of machines such as three-phase motors, transformers, welding equipment, etc. Since these fields continuously build up and decay, the reactive power oscillates between the generator and the consumer equipment. In contrast to active power, it cannot be used, i.e. converted into another form of energy, and places a load on the power supply network and the generating equipment (generators and transformers). Further, all energy distribution systems must be dimensioned larger to accommodate the reactive current.

It is therefore expedient to reduce the inductive reactive power which arises close to the consumer by means of a counteracting capacitive reactive power of as nearly the same size as possible. This process is called compensating. With compensation, the proportion of inductive reactive power in the network is reduced by the reactive power of the power capacitor or the compensation system (PFC). The generator plants and power transmission equipment are thereby relieved of the reactive current. The phase shift between current and voltage is reduced or, ideally, eliminated altogether with a power factor of 1.

The power factor is a parameter that can be affected by network disturbances such as distortion or unbalance. It deteriorates with progressive phase shift between current and voltage and with increasing distortion of the current curve. It is defined as the quotient of the amount of active power and apparent power and is thus a measure of the efficiency with which a load uses electrical energy. Thus, a higher power factor represents improved utilization of electrical energy and ultimately higher efficiency.

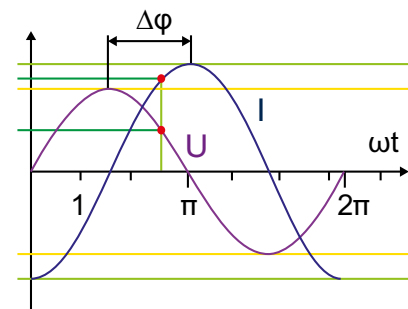

Fig.: Phase shift between current and voltage ($\Delta\varphi$)



Fig.: Principle of power factor correction

POWER FACTOR (ARITHMETIC)

- The power factor is unsigned

$\cos \varphi$ – Fundamental power factor

- Only the fundamental oscillation component is used for the calculation of $\cos \varphi$
- Sign of $\cos \varphi$ (φ):
 - = for delivery of active power
 - + = for consumption of active power

Since no uniform phase shift angle can be specified for harmonic loads, the power factor λ and the frequently used effective factor $\cos(\varphi_1)$ must not be equated. Based on the formula $\lambda = \frac{P}{S} = \frac{1}{I} \cos(\varphi_1) = g_1 \cos(\varphi_1)$ with I_1 = fundamental RMS value of the current, I = total RMS value of the current, g_1 = fundamental oscillation component of the current and $\cos(\varphi_1)$ = displacement factor, it can be seen that only for sinusoidal voltage and current ($g = 1$) is the power factor λ equal to the displacement factor $\cos(\varphi_1)$. Thus, only for sinusoidal currents and voltages is the power factor λ equal to the cosine of the phase shift angle φ and is defined as the $\cos(\varphi) = \frac{P}{S} =$ effective factor.

$$PF_A = \frac{|P|}{S_A}$$

Fig.: Power factor (arithmetic)

$$PF_1 = \cos(\varphi) = \frac{P_1}{S_1}$$

Fig.: $\cos \varphi$ – Fundamental power factor

RCM (RESIDUAL CURRENT MONITORING)

DIFFERENTIAL CURRENT OR RESIDUAL CURRENT MEASUREMENT

Residual currents caused by insulation faults can pose a considerable safety risk in electrotechnical systems. By means of an appropriate protection concept, it is possible to detect residual currents, eliminate insulation faults in good time and thus ensure the availability of the system.

RCM stands for Residual Current Monitoring and means the monitoring of the residual current in electrical installations. This current is calculated from the sum of the currents of all conductors that lead into the system except the protective conductor (PE). Residual currents are typically the result of insulation faults, leakage currents or EMC filter leakage currents, for example.

While RCD devices (residual current circuit breakers) switch off the power supply when a certain residual current is exceeded, RCM measurement devices display the current value, record the long-term history and report any exceedance of a critical value. This message can also be used to switch off the power supply via external switching devices (contactors, relays). Residual current monitoring (RCM) devices are used to detect and report residual currents at an early stage. Countermeasures can be initiated in time so that the system does not have to be shut down. This allows measures to be taken in the event of slowly deteriorating insulation values or gradually increasing residual currents, for example due to aging insulation, even before the system is shut down, e.g.:

- Insulation faults on cables and electrical equipment
- Electrical consumer leakage currents
- Defective PP power capacitors for the PFC
- Defective components in switching power supplies, e.g. in computers
- Correctness of TN-S systems (Terra Neutral Separate)
- Detection of improper PEN connections
- Avoidance of neutral return currents on grounded equipment

Residual current measurement in connection with energy measurement in combined energy / RCM measurement devices in electrical installations is a preventive measure of fire protection and maintenance. Downtime and the associated costs are reduced. Maintenance that is both timely and preventive also significantly improves the economic efficiency and availability of an installation due to the additional information gained from an RCM measurement device.

Continuous RCM monitoring in particular is essential in order to avoid any unwanted surprises during operation and to ensure that information on the current status of the system is always at hand.

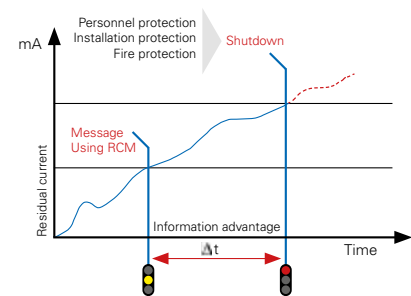

Fig.: Alert before switching off – an objective of residual current monitoring

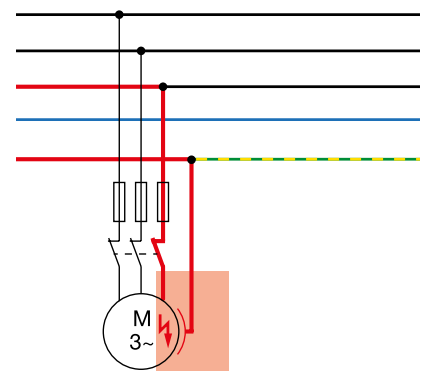
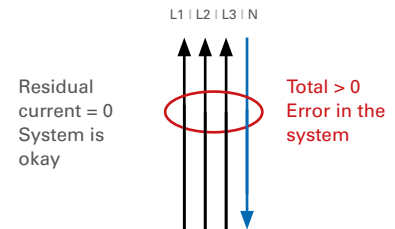

Fig.: Residual current to ground through a high impedance ground fault

BASIC MEASUREMENT PROCEDURE FOR RCM

The operation of RCM devices is based on the residual current principle. All conductors at the measurement point (feeder to be protected), with the exception of the protective conductor, are routed through a residual current transformer. In fault-free operation, the sum of all currents is zero. If, on the other hand, a residual current flows to ground, the current difference in the residual current transformer causes a current which is evaluated by the electronics of the RCM measurement device.

The measurement method is described in IEC/TR 60755. A distinction is made between type A and type B.



THE DIN EN 62020 / VDE 0663 / IEC 62020 STANDARD:

The standard applies to residual current monitoring devices for domestic installations and similar applications with a rated voltage < 440 V AC and a rated current < 125 A.

The UMG96RM-E can measure residual currents according to IEC/TR 60755 (2008-01)

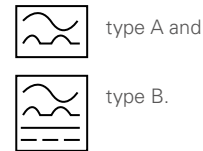

OPTIMAL MONITORING DUE TO 6 CURRENT MEASUREMENT CHANNELS

Modern, highly integrated measurement devices allow the combined measurement of

- electrical parameters (V, A, Hz, kW ...)
- Power quality parameters (harmonics, THD, KUs ...)
- Energy consumption (kWh, kvarh ...)
- RCM residual current in only one measurement device. The following example shows a meter with 6 current inputs for this purpose:

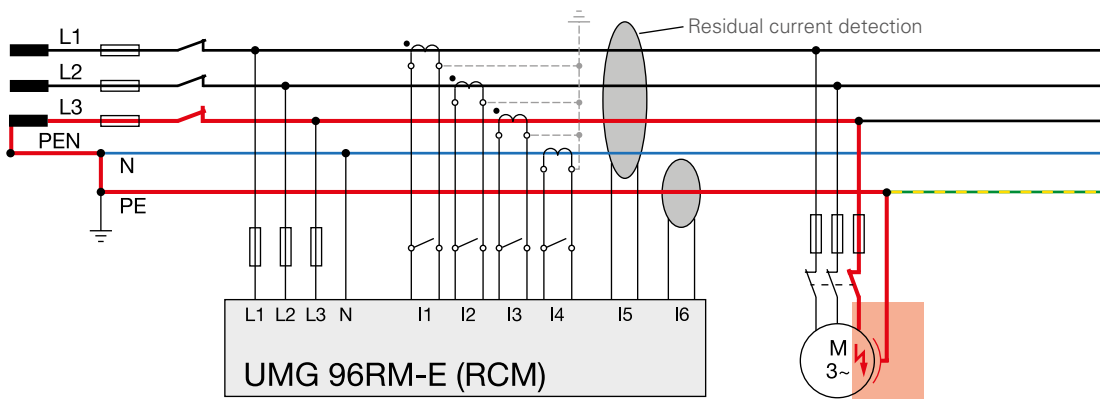

FUNDAMENTALS OF POWER FACTOR CORRECTION

ACTIVE POWER

If an active resistance, e.g. a heater, is connected to an AC circuit, the current and voltage are in phase. Multiplying related instantaneous values of current (I) and voltage (U) yields the instantaneous values of power (P) for alternating current. The curve of the active power is always positive with double mains frequency.

The AC power has the peak value $P = U \times I$. It can be converted into an equivalent DC power, the so-called active power P, by area transformation. In the case of active resistance, the active power is half the peak power.

To determine the AC power, the effective values are always used for the calculation.

$$P = U \cdot I$$

[W] [V] [A]

Fig.: Formula for active power

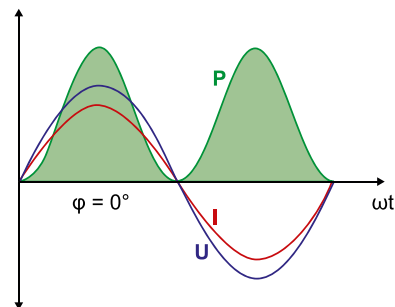

P: ■ U: ■ I: ■

Fig.: AC power for a purely resistive load

ACTIVE AND REACTIVE POWER

A purely resistive load rarely occurs in practice. Often, there is an inductive component as well. This applies to all consumers that require a magnetic field to function (e.g. motors, transformers, etc.). The current used to build up and reverse the polarity of the magnetic field is not consumed, but oscillates as reactive current between the generator and the consumer.

A phase shift occurs, i.e. the zero crossings of voltage and current are no longer congruent. With an inductive load, the current follows the voltage; with a capacitive load, the relationship is exactly the opposite. If we now calculate the instantaneous values of the power ($P = U \times I$), negative values always occur when one of the two factors becomes negative.

$$P = U \cdot I \cdot \cos \varphi$$

[W] [V] [A]

Fig.: Calculation of active power for resistive and inductive loads

Example:

Phase shift $\varphi = 45^\circ$ (corresponds to an inductive $\cos \varphi = 0.707$).
The power curve overlaps into the negative range.

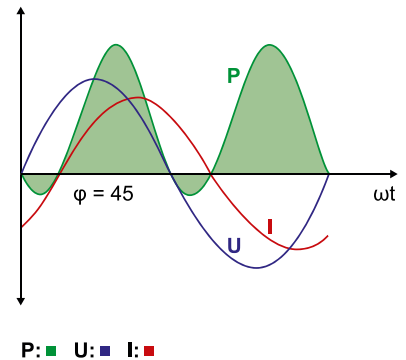

Fig.: Voltage, current and power for mixed resistive, inductive loads

REACTIVE POWER

Inductive reactive power occurs, for instance, in motors and transformers – without taking into account line, iron and friction and windage losses.

If the phase shift between current and voltage is 90° , e.g. for an "ideal" inductance or for a capacitance, the positive and the negative surface components will be equal. The active power then corresponds to the factor 0 and only reactive power occurs. All the energy oscillates back and forth between the consumer and the producer.

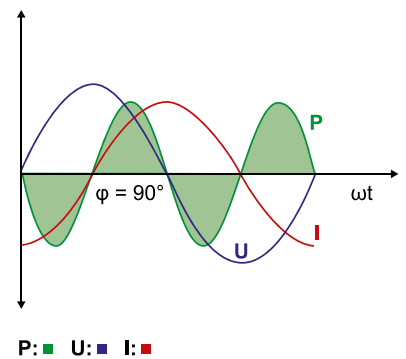

Fig.: Voltage, current and power for a purely reactive load

$$Q = U \cdot I \cdot \sin \varphi$$
$$[\text{var}] [\text{V}] [\text{A}]$$

Fig.: Determination of the inductive reactive power

APPARENT POWER

The apparent power characterizes the electrical power supplied or to be supplied to an electrical consumer. The apparent power S results from the RMS values of current I and voltage U .

When the reactive power approaches zero, e.g. with DC voltage, the apparent power is equal to the amount of the active power. Otherwise it is greater. Electrical equipment (transformers, switchgear, fuses, electric lines, etc.) that transmit power must be designed according to the apparent power to be transmitted.

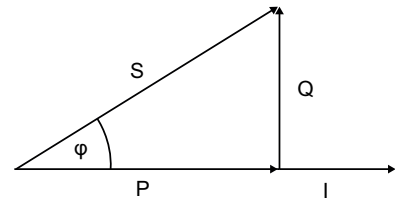

Fig.: Performance diagram

$$S = U \cdot I$$

[VA] [V] [A]

Fig.: Apparent power with no phase shift

APPARENT POWER FOR SINUSOIDAL QUANTITIES

For sinusoidal quantities, the displacement reactive power Q occurs when the phases of current and voltage are shifted by an angle φ .

$$S = \sqrt{P^2 + Q^2}$$

[VA] [W] [var]

Fig.: The apparent power results from the geometric addition of active and reactive power.

POWER FACTOR (COS φ AND TAN φ)

The ratio of active power P to apparent power S is called the active power factor or effective factor. The power factor can be between 0 and 1.

For sinusoidal currents, the active power factor coincides with the cosine ($\cos \varphi$). It is defined by the ratio P/S . The active power factor is a measure of which part of the apparent power is converted into active power. At constant active power and voltage, the apparent power and current are smaller the greater the active power factor $\cos \varphi$.

The tangent (\tan) of the phase shift angle (φ) allows a simple conversion of the reactive and active units.

$$\cos \varphi = \frac{P}{S} \quad [\text{W}] / [\text{VA}]$$

Fig.: Determination of the power factor via active and apparent power

$$\tan \varphi = \frac{Q}{P} \quad [\text{var}] / [\text{W}]$$

Fig.: Calculation of phase shift via reactive and active power

The cosine and the tangent are related as follows:

$$\cos \varphi = \sqrt{\frac{1}{1 + \tan^2 \varphi}}$$

Fig.: Relationship to $\cos \varphi$ and $\tan \varphi$

In power supply installations, the aim is to achieve the highest possible power factor in order to avoid transmission losses. Ideally, it is exactly 1, but practically it is only about 0.95 (inductive). Energy supply companies often prescribe a power factor of at least 0.9 for their customers. If this value is not reached, the applied reactive energy is billed separately. However, this is irrelevant for private households. To increase the power factor, systems are used to compensate for reactive power. If capacitors of a suitable size are connected in parallel with the loads, the reactive current oscillates between the capacitor and the inductive load. The higher-order network is no longer subject to an additional load. If a power factor of 1 can be reached through the use of compensation, only active current is transmitted.

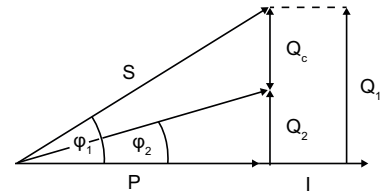

Fig.: Power diagram using power factor correction

The reactive power Q_c , which is absorbed by or dimensioned according to the capacitor, is the difference between the inductive reactive power Q_1 before compensation and Q_2 after compensation.

It follows that: $Q_c = Q_1 - Q_2$

$$Q_c = P \cdot (\tan \varphi_1 - \tan \varphi_2)$$

[var] [W]

Fig.: Calculation of reactive power for improvement of the power factor

CALCULATION FORMULAS FOR THE CAPACITOR

CAPACITOR POWER, SINGLE PHASE

Example: 66.5 μF at 400 V / 50 Hz
 $0.0000665 \times 400^2 \times 2 \times 3.14 \times 50 = 3.340 \text{ var} = 3.34 \text{ kvar}$

$$Q_c = C \cdot U^2 \cdot 2 \cdot \pi \cdot f_n$$

CAPACITOR POWER WITH DELTA CONNECTION

Example: 3 x 57 μF at 480 V / 50 Hz
 $3 \times 0.000057 \times 480^2 \times 2 \times 3.14 \times 50 = 12.371 \text{ var} = 12.37 \text{ kvar}$

$$Q_c = 3 \cdot C \cdot U^2 \cdot 2 \cdot \pi \cdot f_n$$

CAPACITOR POWER WITH STAR CONNECTION

Example: 3 x 33.2 μF at 400 V / 50 Hz
 $3 \times 0.0000332 \times (400 / 1.73)^2 \times 2 \times 3.14 \times 50 = 1670 \text{ var} = 1.67 \text{ kvar}$

$$Q_c = 3 \cdot C \cdot (U / \sqrt{3})^2 \cdot 2 \cdot \pi \cdot f_n$$

CAPACITOR CURRENT IN THE PHASE CONDUCTOR

Example: 25 kvar at 400 V
 $25,000 / (400 \times 1.73) = 36 \text{ A}$

$$I = \frac{Q}{U \cdot \sqrt{3}}$$

$$Q_c = I \cdot U \cdot \sqrt{3}$$

SERIES RESONANT FREQUENCY (FR) AND CHOKING FACTOR (P) OF CHOKED CAPACITORS

Example: $p = 0.07$ (7% choking) in the 50 Hz network

$$f_r = 50 \cdot \sqrt{\frac{1}{0.07}} = 189 \text{ Hz}$$

$$f_r = f_n \cdot \sqrt{\frac{1}{p}} \quad p = \left(\frac{f_n}{f_r} \right)^2$$

REQUIRED CAPACITOR NOMINAL RATING, THREE-PHASE IN CHOKED VERSION

Example: 3 x 308 µF at 400 V / 50 Hz with p = 7% choked

$$0.000308 \times 3 \times 4002 \times 2 \times 3.14 \times 50 / (1 - 0.07) = 50 \text{ kvar}$$

$$Q_c = \left(1 - \frac{7}{100}\right) \cdot \frac{440^2}{400^2} \cdot 50 = 56,3 \text{ kvar}$$

Which capacitor should be used for this?

This means that for a 50-kvar stage, a 440-V 56-kvar capacitor is needed.

$$Q_c = \frac{C \cdot 3 \cdot U^2 \cdot 2 \cdot \pi \cdot f_n}{1 - p}$$

$$Q_c = \left(1 - \frac{P}{100}\right) \cdot \frac{U_c^2}{U_N^2} \cdot N_c$$

POWER FACTOR AND CONVERSION OF COS AND TAN

$$\cos \varphi = \frac{P}{S}$$

$$\cos \varphi = \sqrt{\frac{1}{1 + \tan^2 \varphi}}$$

Conversion of the capacitor power in dependence on the mains voltage
Determination of the reactive power Q_{neu} C is constant here.

Example:

Grid: 400 V, 50 Hz, 3-phase

Capacitor nominal rating: 480 V, 70 kvar, 60 Hz, 3-phase, delta, unchoked

Question: resulting capacitor nominal power?

$$Q_{\text{new}} = \left(\frac{400}{480}\right)^2 \cdot \frac{50}{60} \cdot 70 = 40,5 \text{ kvar}$$

The resulting compensation power of this 480 V capacitor connected to a 400 V 50 Hz mains is only 40.5 kvar.

$$Q_{\text{neu}} = \left(\frac{U_{\text{neu}}}{U_c}\right)^2 \cdot \frac{f_{\text{neu}}}{f_R} \cdot Q_c$$

Definition

Q_c	Rated power of capacitor
P	Degree of choking
U_c	Capacitor voltage
U_N	Mains voltage
N_c	Effective filter performance
Q_{neu}	New reactive power
U_{neu}	New voltage
f_{neu}	New frequency
f_R	Rated frequency of the capacitor

CABLE CROSS SECTIONS AND FUSES

This table provides a general, non-binding indication of common practice. In addition to being dependent on the nominal power of the PFC system, the connection cross sections and the level of fuse protection required also depend on national regulations, the cable material used and the ambient conditions. The recommendation for fuse current rating is for short-circuit protection – NH fuses are unsuitable for overload protection with power capacitors. The system installer or the planner is responsible for the dimensioning and selection of the cable cross sections and fuses in each individual case.

PFC CABLE CROSS SECTIONS, FUSES (FOR MAINS WITH 400 V / 50 HZ)			
POWER KVAR	NOMINAL CURRENT A	CABLE CROSS SECTION NYY-J MM ²	NH FUSE IN THE OUTGOING FEEDER
5	7	4 x 2.5	16
7.5	10	4 x 4	20
10	14	4 x 4	25
12.5	18	4 x 6	35
15	22	4 x 6	35
17.5	25	4 x 10	50
20	29	4 x 10	50
25	36	4 x 16	63
30	43	4 x 16	80
37.5	54	4 x 25	100
50	72	3 x 35/16	125
55 – 65	79 – 94	3 x 35/16	160
70 – 85	101 – 123	3 x 70/35	200
86 – 100	124 – 145	3 x 95/50	250
101 – 125	146 – 181	3 x 120/70	250
126 – 160	182 – 231	2"3 x 70/35	315
161 – 180	233 – 260	2"3 x 95/50	400
181 – 200	261 – 289	2"3 x 120/70	400
201 – 250	290 – 361	2"3 x 150/70	500
251 – 300	362 – 434	2"3 x 185/95	630

Connection cross sections apply only for the specified capacitor ratings

Important note:

When expanding existing installations, the busbar separation must be carried out beforehand!

Power factor correction systems with a capacity above 300 kvar have two separate busbar systems and require two separate incoming power feeders. The table applies for unchoked and choked compensation systems. In any case, the currently valid regulations (e.g. DIN VDE 0298) must be observed.

COS PHI

CALCULATION OF THE REQUIRED KVAR COMPENSATION SYSTEM POWER

This selection table was created to facilitate the calculation of the required reactive power. You can use the current power factor and the target power factor to determine a multiplier from the table and multiply it by the active power to be compensated. The result is the required reactive power for your power factor correction system. This table can also be found as an MS Excel file for calculation on our homepage at <http://www.janitza.com/downloads/tools/kvar-table/>.

cos phi selection table

Active power $P = 100 \text{ kW}$
 ACTUAL $\cos \phi = 0.65$
 TARGET $\cos \phi = 0.95$
 Factor F from table $= 0.84$
 Compensation power $Q_C = P \times (\tan \phi_1 - \tan \phi_2)$
 $P \times F = 100 \times 0.84 = 84 \text{ kvar}$

ACTUAL tan ϕ	cos ϕ	Target power factor cos ϕ										
		0.80	0.82	0.85	0.88	0.90	0.92	0.94	0.95	0.96	0.98	1.00
1.33	0.60	0.58	0.64	0.71	0.79	0.85	0.91	0.97	1.00	1.04	1.13	1.33
1.30	0.61	0.55	0.60	0.68	0.76	0.81	0.87	0.94	0.97	1.01	1.10	1.30
1.27	0.62	0.52	0.57	0.65	0.73	0.78	0.84	0.90	0.94	0.97	1.06	1.27
1.23	0.63	0.48	0.53	0.61	0.69	0.75	0.81	0.87	0.90	0.94	1.03	1.23
1.20	0.64	0.45	0.50	0.58	0.66	0.72	0.77	0.84	0.87	0.91	1.00	1.20
1.17	0.65	0.42	0.47	0.55	0.63	0.68	0.74	0.81	0.84	0.88	0.97	1.17
1.14	0.66	0.39	0.44	0.52	0.60	0.65	0.71	0.78	0.81	0.85	0.94	1.14
1.11	0.67	0.36	0.41	0.49	0.57	0.62	0.68	0.75	0.78	0.82	0.90	1.11
1.08	0.68	0.33	0.38	0.46	0.54	0.59	0.65	0.72	0.75	0.79	0.88	1.08
1.05	0.69	0.30	0.35	0.43	0.51	0.56	0.62	0.69	0.72	0.76	0.85	1.05
1.02	0.70	0.27	0.32	0.40	0.48	0.54	0.59	0.66	0.69	0.73	0.82	1.02
0.99	0.71	0.24	0.29	0.37	0.45	0.51	0.57	0.63	0.66	0.70	0.79	0.99
0.96	0.72	0.21	0.27	0.34	0.42	0.48	0.54	0.60	0.64	0.67	0.76	0.96
0.94	0.73	0.19	0.24	0.32	0.40	0.45	0.51	0.57	0.61	0.64	0.73	0.94
0.91	0.74	0.16	0.21	0.29	0.37	0.42	0.48	0.55	0.58	0.62	0.71	0.91
0.88	0.75	0.13	0.18	0.26	0.34	0.40	0.46	0.52	0.55	0.59	0.68	0.88
0.86	0.76	0.11	0.16	0.24	0.32	0.37	0.43	0.49	0.53	0.56	0.65	0.86
0.83	0.77	0.08	0.13	0.21	0.29	0.34	0.40	0.47	0.50	0.54	0.63	0.83
0.80	0.78	0.05	0.10	0.18	0.26	0.32	0.38	0.44	0.47	0.51	0.60	0.80
0.78	0.79	0.03	0.08	0.16	0.24	0.29	0.35	0.41	0.45	0.48	0.57	0.78
0.75	0.80		0.05	0.13	0.21	0.27	0.32	0.39	0.42	0.46	0.55	0.75
0.72	0.81		0.03	0.10	0.18	0.24	0.30	0.36	0.40	0.43	0.52	0.72
0.70	0.82			0.08	0.16	0.21	0.27	0.34	0.37	0.41	0.49	0.70
0.67	0.83			0.05	0.13	0.19	0.25	0.31	0.34	0.38	0.47	0.67
0.65	0.84				0.03	0.11	0.16	0.22	0.28	0.32	0.44	0.65
0.62	0.85					0.08	0.14	0.19	0.26	0.29	0.42	0.62
0.59	0.86					0.05	0.11	0.17	0.23	0.26	0.39	0.59
0.57	0.87						0.03	0.08	0.14	0.20	0.36	0.57
0.54	0.88							0.06	0.11	0.18	0.34	0.54
0.51	0.89								0.03	0.09	0.18	0.51
0.48	0.90									0.06	0.16	0.48
0.46	0.91										0.13	0.46
0.43	0.92											0.43
0.40	0.93											0.40
0.36	0.94											0.36
0.33	0.95											0.33
0.29	0.96											0.29
0.25	0.97											0.25

FIXED COMPENSATION

SELECTION TABLE FOR FIXED COMPENSATION OF MOTORS

MOTOR POWER IN KW	CAPACITOR POWER AT NO LOAD IN KVAR (DEPENDING ON REVOLUTIONS/MINUTE)			
	3000	1500	1000	750
1.5	0.8	1	1.1	1.2
3	1.5	1.6	1.8	2.3
5.5	2.2	2.4	2.7	3.2
7.5	3.4	3.6	4.1	4.6
11	5	5.5	6	7
15	6.5	7	8	9
18.5	8	9	10	11
22	10	11	12	13
30	14	15	17	20
45	19	21	24	28
75	28	32	37	41
90	34	39	44	49
110	40	46	52	58

Guide values for individual compensation of motors according to VDEW



Comment:

- The values serve only as a guideline
- Overcompensation must be avoided to prevent overexcitation

SELECTION TABLE FOR FIXED COMPENSATION OF TRANSFORMERS

TRANSFORMER RATED POWER IN KVA	CAPACITOR NOMINAL POWER IN KVAR
100	4.8
160	6.25
200	7.2
250	7.5
315	9.3
400	10
500	12.5
630	15
800	20
1000	25
1250	30
1600	40
2000	50



Comment:

- values are only indicative (for three-phase transformers with normal losses, the compensation power is between 1 and 5% of their nominal power, depending on their size).
- The observance of regional electric utility regulations is mandatory.
- Make sure that appropriate back-up fuses and short-circuit-proof cables are used.

CONTINUOUS MEASUREMENT

HISTORY

In the past, the processors available on the market were not powerful enough to measure and simultaneously calculate the various parameters.

Consequently, only random measurements were carried out with older measurement devices. That meant that measurements were made for a few periods, then the measurement was stopped and the values were calculated. No further measurement was performed while processing was being carried out. Thus, out of 50 periods, only some periods were actually measured.

TODAY

The new product families, such as the UMG 96RM, UMG 604-PRO, UMG 605-PRO, UMG 509-PRO, UMG 512-PRO, use cutting edge microprocessors with completely new architecture, an integrated range of capabilities and considerably higher performance.

Processors like this were not available in the past! These processors are more expensive than the conventional processors which are still widely used in many simple measurement devices. The above-mentioned product families employ continuous measurement. Here, all periods are recorded, i.e. out of 50 periods, 50 periods are measured. At the same time, the data are processed and the various electrical, PQ and energy parameters are calculated.

It is self-evident that this results in a significant improvement in measuring accuracy. Another point to be considered is that in the case of rapid load changes (e.g. spot welding), random measurement can lead to a considerable deviation in the measurement result and in the working measurement.

"EVERY MEASUREMENT DEVICE MEASURES CONTINUOUSLY, DOESN'T IT ...?"

Customer quote

MARKET SITUATION

Simple measurement devices and measurement devices with an inexpensive or older design for the measuring electronics are still offered and use random measurement. When the world market is considered, it appears that random measurement will in fact still prevail and be considered state of the art!

It is also common for the work to be measured continuously, while all other values are not determined continuously, but only by sampling.

SUMMARY

Continuous measurement requires higher quality components. The continuous measurement of all values results in the achievement of significantly higher measuring accuracies.

MEASURE, CALCULATE, STORE – RING BUFFERS ARE A THING OF THE PAST!

As described already in detail in the previous article, the current generation of our measurement devices has very powerful digital signal processors (DSP) which allow continuous and uninterrupted acquisition of current and voltage, as well as the calculation of all conceivable parameters. What are the details about how this is done, how does the measuring process work, in what form are measured values available and where are they stored?

Modern measurement devices like our UMGs can basically be thought of as PCs. The main players are the CPU (DSP), RAM, hard disk (flash memory) and communication ports (RS-485, RJ45).

The following groups of measured values must be distinguished:

ONLINE VALUES

Online values are determined over a measurement interval of 200 ms or as the average of the full-wave RMS values of 10 periods. Online values are all values that the measurement device continuously determines and calculates. Depending on the measurement device, this means up to 2,000 values are available per 200 ms for all measuring channels. The most important of these can be read directly from the displays of the UMGs. The entire range of measured values can be displayed via the GridVis® software and in the topology views.

All measured values are available continuously in defined Modbus memory registers for external access by suitable third-party software.

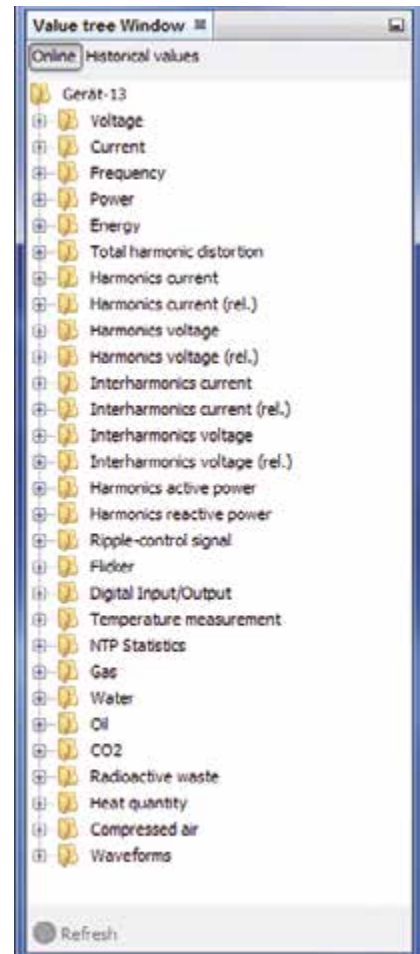

Fig.: Online values, UMG 605-PRO value tree

HISTORICAL VALUES

RECORDINGS

Historical values are formed from the online values. To do this, one or more recording configurations are created in the device configuration. A time period for the formation of an average value is defined for the respective recording, e.g. 15-minute averages for the recording of load curves, 1-hour averages for energy, etc. The time periods can range from 200 ms to several days, depending on the device type. For power quality measurements according to EN 50160, EN 61000-2-4 or EN 50160, IEEE519, predefined recording configurations are available and can be activated by mouse click.

Historical values are usually first stored in the measurement device on internal flash memory. Formerly this was also called a ring buffer. Each stored value receives a timestamp. The values can be read out manually or automatically (Service) via the GridVis® software. The measured value and timestamp are stored in a database. These values can then be evaluated in tabular or graphical form via GridVis® or external database tools.



Fig.: Customer-specific historical recordings, UMG 604-PRO value tree

EVENTS

Events are overvoltages, undervoltages and overcurrents. The basis here are the 20-ms full-wave RMS values for the UMG 604-PRO and UMG 509-PRO or the 10-ms half-wave RMS values for the UMG 605-PRO and UMG 512-PRO. When the defined tolerance limits are exceeded or undershot, the event is stored in the flash memory. In addition, a pre- and post-event period is defined so that network events can be analyzed immediately before and after the occurrence of the event. Thus, a maximum of all voltage and current channels can be displayed graphically and coherently over the specified evaluation period.



Fig.: Event recording, voltage dip/undervoltage

TRANSIENTS

Recording transients requires the full performance capacity of the UMGs. At a sampling rate of 20 kHz, transients as of 50 µs can be recorded. Similar to the recording of events, threshold values as well as lead and lag times can be defined here as well. In the same way, it is possible to specify which channels are to be recorded in a graph as a waveform simultaneously with the occurrence of transients.

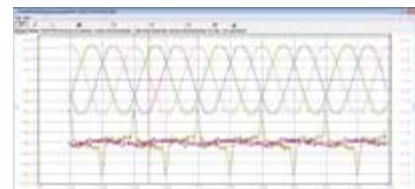

Fig.: Transients recording

FLAGS

Flags are used to mark and store irregularities during measurement and recording according to the IEC 61000-4-30 standard. For example, causes of recording gaps can be identified.

Flag	Note
LostWindow	200 ms measuring window has been lost
LostPLL	The device has lost the network synchronization
Overcurrent	Overrange A
Overvoltage	Overrange V
Firmware upgrade	Firmware upgrade
Initialization	Initialization buffer



Fig.: Flag recording

All recordings of historical data, events, transients and flags run in the measurement device continuously, independently of each other, and in parallel.

All stored data are stored in a historically sorted form. If the flash memory is full, the historically oldest data are overwritten. By regularly reading the data into a database, values that are to be overwritten on the measurement device can already be stored on the server, so that no measured values are lost.

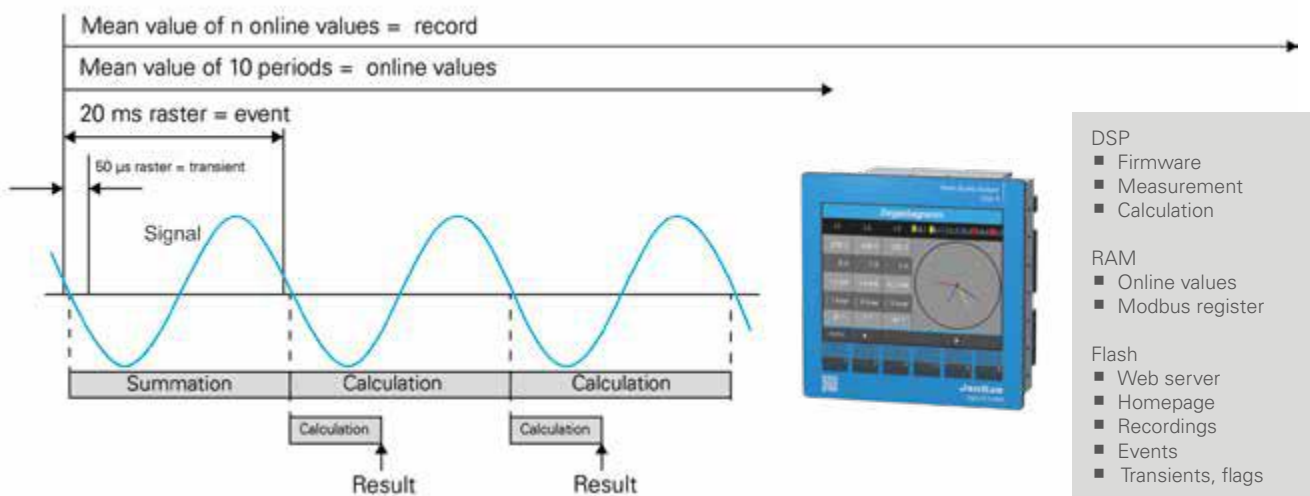

FORMULARY

RMS value of current for phase conductor p

$$I_p = \sqrt{\frac{1}{N} \cdot \sum_{k=0}^{N-1} i_{pk}^2}$$

RMS value of the neutral conductor current

$$I_N = \sqrt{\frac{1}{N} \cdot \sum_{k=0}^{N-1} (i_{1k} + i_{2k} + i_{3k})^2}$$

RMS voltage L-N

$$U_{pN} = \sqrt{\frac{1}{N} \cdot \sum_{k=0}^{N-1} u_{pNk}^2}$$

RMS voltage L-L

$$U_{pg} = \sqrt{\frac{1}{N} \cdot \sum_{k=0}^{N-1} (u_{gNk} - u_{pNk})^2}$$

Star point voltage (vectorial)

$$U_{\text{Star point voltage}} = U_{1ms} + U_{2ms} + U_{3ms}$$

Active power for phase conductor

$$P_p = \frac{1}{N} \cdot \sum_{k=0}^{N-1} (u_{pNk} \times i_{pk})$$

Apparent power for phase conductor p

- The apparent power is unsigned.

$$S_p = U_{pN} \cdot I_p$$

Total apparent power (arithmetic)

- The apparent power is unsigned.

$$S_A = S_1 + S_2 + S_3$$

Ordinal numbers of the harmonics

xxx[0] = fundamental oscillation (50Hz/60Hz)
xxx[1] = 2nd harmonic (100Hz/120Hz)
xxx[2] = 3rd harmonic (150Hz/180Hz)
etc.

THD

- THD (Total Harmonic Distortion) is the distortion factor and indicates the ratio of the harmonic components of an oscillation to the fundamental oscillation.

The voltage distortion factor

- M = Ordinal number of the harmonic
- M = 50 (UMG 605-PRO, UMG 512-PRO)
- Fundamental oscillation fund is n = 1

$$THD_U = \frac{1}{|U_{fund}|} \sqrt{\sum_{n=2}^M |U_{n.Harm}|^2}$$

The current distortion factor

- M = Ordinal number of the harmonic
- M = 50 (UMG 605-PRO, UMG 512-PRO)
- Fundamental oscillation fund is n = 1

$$THD_I = \frac{1}{|I_{fund}|} \sqrt{\sum_{n=2}^M |I_{n.Harm}|^2}$$

ZHD

- ZHD is the THD for the interharmonics
- It is calculated in the UMG 605-PRO

Interharmonics

- Sinusoidal oscillations whose frequencies are not an integer multiple of the mains frequency (fundamental oscillation)
- It is calculated in the UMG 605-PRO
- Calculation and measurement methods comply with DIN EN 61000-4-30
- The ordinal number of an intermediate harmonic corresponds to the ordinal number of the next smallest harmonic. For example, the 3rd intermediate harmonic lies between the 3rd and 4th harmonic.

TDD (I)

- TDD (Total Demand Distortion) indicates the ratio between the current harmonics (THD_I) and the current RMS value at full load.
- I_L = Full load current
- M = 50 (UMG 605-PRO, UMG 512-PRO)

$$TDD = \frac{1}{I_L} \sqrt{\sum_{n=2}^M I_n^2} \times 100\%$$

RIPPLE CONTROL SIGNAL U (EN 61000-4-30)

The ripple control signal U is a voltage (200 ms measured value) measured at a carrier frequency specified by the user. Only frequencies below 3 kHz are considered.

RIPPLE CONTROL SIGNAL I

The ripple control signal I is a current (200 ms measured value) measured at a carrier frequency specified by the user. Only frequencies below 3 kHz are considered.

POSITIVE, NEGATIVE, AND ZERO SEQUENCE COMPONENT

- The magnitude of a voltage or current unbalance in a three-phase system is characterized by means of the positive sequence, negative sequence, and zero sequence components.
- The symmetry of three-phase systems that is desirable during normal operation is disturbed by unbalanced loads, faults and equipment.
- A three-phase system is called symmetrical if the three phase-to-phase voltages and currents are of equal magnitude and 120° out of phase with each other. If one or both conditions are not met, the system is said to be unbalanced. A simplified analysis of an unbalanced fault in a three-phase system is possible by calculating the symmetrical components consisting of the positive sequence, negative sequence and zero sequence.
- Unbalance is a power quality characteristic for which limits have been defined in international standards (e.g. EN 50160).

Positive sequence component

$$U_{Mit} = \frac{1}{3} \left| U_{L1,fund} + U_{L2,fund} \cdot e^{j\frac{2\pi}{3}} + U_{L3,fund} \cdot e^{j\frac{4\pi}{3}} \right|$$

Negative sequence component

$$U_{Geg} = \frac{1}{3} \left| U_{L1,fund} + U_{L2,fund} \cdot e^{-j\frac{2\pi}{3}} + U_{L3,fund} \cdot e^{-j\frac{4\pi}{3}} \right|$$

Zero sequence component

A zero component can only occur if a summation current can flow back via the neutral conductor.

$$U_{\text{Zero sequence component}} = \frac{1}{3} |U_{L1,fund} + U_{L2,fund} + U_{L3,fund}|$$

Voltage unbalance

$$Unbalance = \frac{U_{\text{pos}}}{U_{\text{neg}}}$$

Downward deviation U (EN 61000-4-30)

$$U_{\text{unter}} = \frac{U_{\text{din}} - \sqrt{\frac{\sum_{i=1}^n U_{\text{rms-}i}^2}{n}}}{U_{\text{din}}} [\%]$$

Downward deviation I

$$I_{\text{under}} = \frac{I_{\text{Nominal current}} - \sqrt{\frac{\sum_{i=1}^n I_{\text{rms-}i}^2}{n}}}{I_{\text{Nominal current}}} [\%]$$

K factor

- The K factor describes the increase in eddy current losses with a harmonics load. With a sinusoidal load on the transformer, the K factor = 1. The larger the K-factor, the greater a transformer's capacity for being loaded with harmonics without overheating.

Power factor (arithmetic)

- The power factor is unsigned.

$$PF_A = \frac{|P|}{S_A}$$

cos phi – Fundamental Power Factor

- Only the fundamental oscillation component is used to calculate cos phi
- cos phi sign:
 - = for delivery of active power
 - + = for consumption of active power

$$PF_1 = \cos(\varphi) = \frac{P_1}{S_1}$$

cos phi sum

- cos phi sign:
 - = for delivery of active power
 - + = for consumption of active power

$$\cos(\varphi)_{Sum_3} = \frac{P_{1fund} + P_{2fund} + P_{3fund}}{\sqrt{(P_{1fund} + P_{2fund} + P_{3fund})^2 + (Q_{1fund} + Q_{2fund} + Q_{3fund})^2}}$$

$$\cos(\varphi)_{Sum_4} = \frac{P_{1fund} + P_{2fund} + P_{3fund} + P_{4fund}}{\sqrt{(P_{1fund} + P_{2fund} + P_{3fund} + P_{4fund})^2 + (Q_{1fund} + Q_{2fund} + Q_{3fund} + Q_{4fund})^2}}$$

Phase angle Phi

- The phase angle between the current and voltage of phase conductor p is calculated and displayed according to DIN EN 61557-12.
- The sign of the phase angle corresponds to the sign of the reactive power.

Fundamental oscillation reactive power

The fundamental oscillation reactive power is the reactive power of the fundamental and is calculated using Fourier analysis (FFT). The voltage and current do not have to be sinusoidal. All reactive powers calculated in the device are fundamental oscillation reactive powers.

Sign of the reactive power

- Sign Q = +1 for phi in the range 0 ... 180° (inductive)
- Sign Q = -1 for phi in the range 180 ... 360° (capacitive)

$$\text{Sign } Q(\varphi) = +1 \quad \text{if } \varphi \in [0^\circ - 180^\circ]$$

$$\text{Sign } Q(\varphi_p) = -1 \quad \text{if } \varphi_p \in [180^\circ - 360^\circ]$$

Reactive power for phase conductor p

- Reactive power of the fundamental oscillation

$$Q_{fundp} = \text{Sign } Q(\varphi_p) \cdot \sqrt{S_{fundp}^2 - P_{fundp}^2}$$

TOTAL REACTIVE POWER

Reactive powers of the fundamental oscillation

$$Q_V = Q_1 + Q_2 + Q_3$$

REACTIVE DISTORTION POWER

■ The reactive distortion power is the reactive power of all harmonics and is calculated using Fourier analysis (FFT).

$$D = \sqrt{S^2 - P^2 - Q_{fund}^2}$$

- The apparent power S contains the fundamental oscillation and all harmonic components up to the M-th harmonic.
- The active power P contains the fundamental oscillation and all harmonic components up to the M-th harmonic.
- M = 50 (UMG 605-PRO, UMG 512-PRO)

Reactive energy per phase

$$E_{r_{L1}} = \int Q_{L1}(t) \cdot \Delta t$$

Reactive energy per phase, inductive

$$E_{r(ind)_{L1}} = \int Q_{L1}(t) \cdot \Delta t \quad \text{For } Q_{L1}(t) > 0$$

Reactive energy per phase, capacitive

$$E_{r(cap)_{L1}} = \int Q_{L1}(t) \cdot \Delta t \quad \text{For } Q_{L1}(t) < 0$$

Reactive energy, sum L1-L3

$$E_{r_{L1,L2,L3}} = \int (Q_{L1}(t) + Q_{L2}(t) + Q_{L3}(t)) \cdot \Delta t$$

Reactive energy, sum L1-L3, inductive

$$E_{r(ind)_{L1,L2,L3}} = \int (Q_{L1}(t) + Q_{L2}(t) + Q_{L3}(t)) \cdot \Delta t$$

Reactive energy, sum L1-L3, capacitive

$$E_{r(cap)_{L1,L2,L3}} = \int (Q_{L1}(t) + Q_{L2}(t) + Q_{L3}(t)) \cdot \Delta t$$

GENERAL INFORMATION ABOUT CURRENT TRANSFORMERS

GENERAL

Current transformers are primarily used where currents cannot be measured directly. They are special forms of transformers that translate the primary current into a (typically) smaller, standardized secondary current of a certain accuracy (class) and also galvanically separate the primary and secondary circuits. Using saturation properties of the core material, it is possible to protect the secondary circuit, including connected measuring equipment, from overcurrents (short circuit) at nominal conditions.

A basic distinction can be made between single-conductor current transformers and wound current transformers. The most common representative of single-conductor current transformers is the plug-in current transformer, which is plugged onto the current-carrying conductor and thus forms a (short-circuited) transformer with one primary winding (and secondary windings corresponding to the transformer ratio).



Fig.: Plug-in current transformers

SELECTING CURRENT TRANSFORMERS

RATIO

The rated ratio is the ratio of the primary rated current to the secondary rated current and is indicated as an unabbreviated fraction on the rating plate.

For technical, but above all for economic reasons, $x / 1$ A transformers are recommended for long measuring cable lengths. Line losses are calculated as a function of cross section \times length \times current².

PRIMARY CURRENT

The rated or primary current (former designation) is the value of the primary and secondary current (primary rated current, secondary rated current) for which the current transformer is rated, as indicated on the rating plate. The standard values of the primary rated current are: 10 – 12.5 – 15 – 20 – 25 – 30 – 40 – 50 – 60 – 75 A and their decimal multiples and parts. Standardized secondary currents are 1 and 5 A, preferably 5 A.

The correct selection of the primary current is important for the measuring accuracy. A ratio slightly beyond the measured / defined current (I_n) is recommended.

Example: $I_n = 1,154$ A, selected transformer ratio = 1,250/5.

The primary current can also be defined on the basis of the following considerations:

- Dependent on transformer primary current times approx. 1.1 (next transformer size)
- Fuse protection (fuse primary current = transformer primary current) of the measured part of the system (LV MDB, SDP)
- Actual primary current times 1.2 (if the actual current is significantly below the transformer or fuse primary current, this approach should be selected)
- Overdimensioning the current transformer must be avoided, since otherwise the measuring accuracy at relatively low currents (in relation to the primary rated current) drops, in some cases considerably.

RATED POWER

The rated power must be greater than the sum of the power of the cable, the measurement device and any loads and is specified in VA. Standardized values are between 1 and 30 VA according to PTB. Values above 30 VA may also be selected according to the use case. The rated power describes the capacity of a current transformer to "drive" the secondary current through a load and lines while within the fault limits.

When selecting the appropriate power, the following parameters must be taken into account: Measurement device power consumption (for series connection ...), cable length, cable cross section. The longer the cable length and the smaller the cable cross section, the higher the losses through the supply cable, i.e. the nominal power of the transformer must be selected accordingly.

The sum of the consumer power should be close to the transformer rated power, otherwise the measured value may be too positive. A very low load power (under loading) increases the overcurrent factor, and measurement devices may not be adequately protected in the event of a short circuit. Excessive consumer power (overloading) has a negative effect on accuracy.

Often current transformers are already present in an installation and can be used when retrofitting with a measurement device. The nominal power of the transformer must be taken into account here: Is it sufficient to drive the additional measurement devices? For low impedance measurement devices, underloading can be prevented by using an additional load.

ACCURACY CLASSES

Current transformers are divided into classes according to their accuracy. Standard accuracy classes are 0.1; 0.2; 0.5; 1; 3; 5; 0.1S; 0.2S; 0.5S. The class symbol corresponds to an error curve with respect to current and angular errors.

The accuracy classes of current transformers are related to the measured value. If current transformers are operated with a low current in relation to the primary current, the measuring accuracy drops significantly. The following table shows the error limits taking into account the primary current values:

ACCURACY CLASS	CURRENT ERROR f_j IN % AT % OF THE RATED CURRENT					
	1%	5%	20%	50%	100%	120%
5				5		5
3				3		3
1		3	1.5		1	1
0.5		1.5	0.75		0.5	0.5
0.5 S	1.5	0.75	0.5		0.5	0.5
0.2		0.75	0.35		0.2	0.2
0.2 S	0.75	0.35	0.2		0.2	0.2

Calculation of the rated power S_n : Copper wire = 10 m

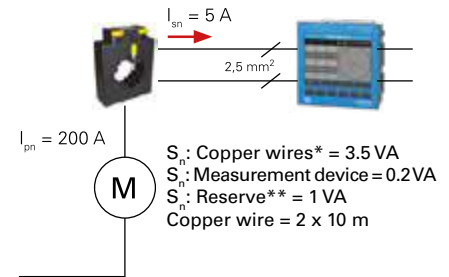

$$S_{n, \text{total}} = S_n \text{ Copper wire}^* + S_n \text{ Measurement device} + S_n \text{ Reserve}^{**}$$

Example: $S_n \text{ total} = 3.50 \text{ VA} + 0.2 \text{ VA} + 1 \text{ VA}$
 $S_n \text{ total} = 4.70 \text{ VA}$ (corresponds to the standardized value of 5 VA)

* Determination of the burden
 ** $S_n \text{ reserve} < 0.5 \times (S_n \text{ copper line} + S_n \text{ measuring instruments})$

Fig.: Calculation of the rated power S_n (copper wire, 10 m)

We always recommend using current transformers with the same accuracy class for the UMG measurement devices. Current transformers with a lower accuracy class result in a higher measuring accuracy in the overall system – current transformer + measurement device – which in this case is defined by the accuracy class of the current transformer. However, the use of current transformers with a lower measuring accuracy than the measurement device is technically possible. As a recommendation, transformers of class 0.5S should be used for billing-relevant measurements.

CURRENT TRANSFORMER ERROR CURVE

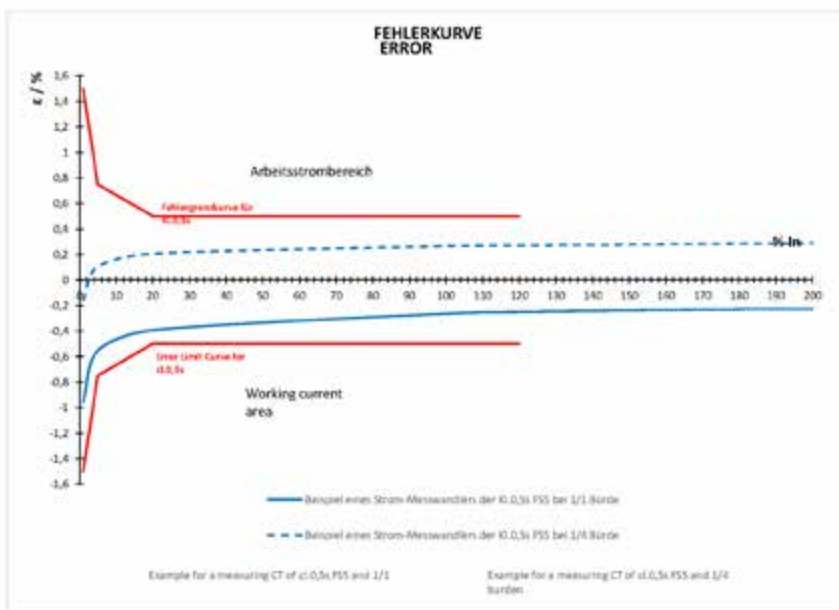

MEASUREMENT TRANSFORMER VS. PROTECTION TRANSFORMER

Whereas measurement transformers should saturate as quickly as possible above their operating current range (expressed by the overcurrent factor FS) in order to prevent the secondary current from increasing in the event of a fault (e.g. short-circuit) and thus protect the connected devices, protection transformers should go into saturation as far outside this range as possible.

Protection transformers are used for system protection purposes in conjunction with the appropriate switchgear. Standard accuracy classes for protection transformers are 5P and 10P. "P" here stands for "protection". The nominal overcurrent factor is placed (in %) after the protection class designation. For example, 10P5 means that at 5 times the primary current, the negative secondary side deviation from the value that would be expected on the basis of the ratio (linear) is at most 10%.

The use of measurement transformers is strongly recommended for the operation of UMG measurement devices.

TRANSFORMER STANDARD RAIL SIZES

TYPE	PRIMARY CURRENTS IN A	RAIL SIZE IN mm	ROUND HOLE
PLUG-IN CURRENT TRANSFORMERS			
IPA30	60 – 600	30 x 10 20 x 20	23
IPA30.5	40 – 300	30 x 10 20 x 20	23
IPA40	75 – 1000	40 x 10 30 x 15	30
IPA40.5	60 – 1000	40 x 10 30 x 15	30
4R21.3	40 – 500	-	21
6A315.3	50 – 750	30 x 10 20 x 20	28
6A412.3	150 – 800	40 x 10 2 x 30 x 10	33
7A412.3	60 – 1000	40 x 10 2 x 30 x 10	33
7A412.6	60 – 400	40 x 10 2 x 30 x 10	33
7A512.3	150 – 1000	50 x 10 2 x 40 x 10 2 x 30 x 10	42
8A512.3	150 – 1500	50 x 10 2 x 40 x 10 2 x 30 x 10	42
8A615.3	200 – 1600	60 x 10 2 x 50 x 10 2 x 40 x 10 3 x 30 x 10	52
9A615.3	200 – 2500	60 x 10 2 x 50 x 10 2 x 40 x 10 3 x 30 x 10	53
9A640.3	200 – 2000	2 x 60 x 10 3 x 50 x 10	61

SPECIAL VERSION	
Deviating primary rated current	On request
Deviating secondary rated current	On request
Deviating construction design	On request
Deviating rated frequency	On request
Enhanced class accuracy and continuous load capacity	On request
Type-approved / calibrated transformers	On request
1.2 kV temperature range	On request

CONSTRUCTION TYPE OF CURRENT TRANSFORMERS

FEEDTHROUGH CURRENT TRANSFORMERS

The conductor to be measured (busbar or cable) is passed through the opening and forms the primary circuit of the feedthrough current transformer. Feedthrough current transformers are mainly used for mounting on busbars. Through additional potting is it possible to achieve droplet resistance as well as higher shock and vibration resistance under mechanical stress (IEC 68). This is the most common current transformer design, but has the disadvantage that the primary conductor must be interrupted during installation. In other words, this transformer design is primarily used when setting up new systems.

SEPARABLE CURRENT TRANSFORMERS

Separable transformers are often used in retrofit applications. With these transformers, the transformer cores can be opened for installation and can thus be mounted around the busbars. This allows mounting without interrupting the primary conductor. It should be noted that separable current transformers are in principle not suitable for billing purposes.

SPLIT CORE TRANSFORMERS

Split core transformers are only suitable for mounting on insulated primary circuit conductors (feeder cables) in a weather-protected and dry location. Mounting is possible without interrupting the primary conductor.



Fig.: Split core transformers

DIN RAIL TRANSFORMERS WITH INTEGRATED BACK-UP FUSE

The DIN rail current transformer is a very compact special design with integrated voltage tap. DIN rail current transformers consists of a terminal block, current transformer and the voltage tap-off terminal with a fuse. The fuse is mounted directly on the primary conductor, meaning the unprotected part of the measuring lead is very short. This ensures a high level of intrinsic safety. The DIN rail current transformer provides simple wiring, low installation costs and higher reliability due to fewer connections, reduced space requirements and fewer connection errors.



Fig.: DIN rail transformer

CURRENT TRANSFORMER INSTALLATION

INSTALLATION ORIENTATION

Determine the direction of energy flow in the cable that you want to measure. P1 denotes the side where the power source is located, while P2 denotes the consumer side.

TERMINALS S1/S2 (K/L)

The terminals of the primary winding are marked with "P1" and "P2" ("K" and "L") and the terminals of the secondary winding are marked with "S1" and "S2" ("k" and "l"). The polarity must be such that the "energy flow direction" runs from "P1" to "P2".

Inadvertently swapping the terminals S1/S2 leads to erroneous measurement results and can also cause incorrect control behaviour with PFC systems.

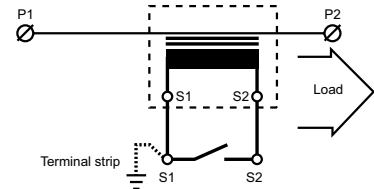

Fig.: Installation orientation

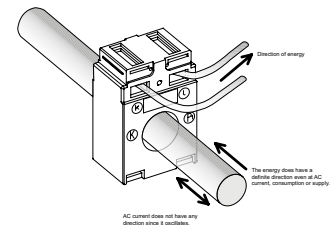

Fig.: Installation orientation of current transformers

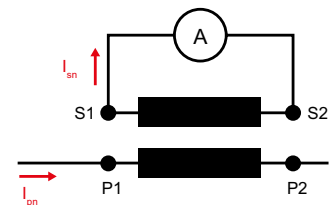

Fig.: Energy flow direction

LINE LENGTH AND CROSS SECTION

The power consumption (P in W) caused by the line losses is calculated as follows:

$$P = \frac{\rho \times l \times I^2}{A}$$

- Resistivity

for CU: 0.0175 Ω * mm² / m

for Al: 0.0278 Ω * mm² / m

l = line length in m (outward and return line)

I = current in amperes

A = cable cross section in mm²

QUICK REFERENCE (POWER CONSUMPTION, CU WIRE) FOR 5 A AND 1 A:

For every 10°C change in temperature, the power absorbed by the cables increases by 4%.

POWER CONSUMPTION IN VA AT 5 A										
NOMINAL CROSS SECTION	1 M	2 M	3 M	4 M	5 M	6 M	7 M	8 M	9 M	10 M
2.5 mm ²	0.36	0.71	1.07	1.43	1.78	2.14	2.50	2.86	3.21	3.57
4.0 mm ²	0.22	0.45	0.67	0.89	1.12	1.34	1.56	1.79	2.01	2.24
6.0 mm ²	0.15	0.30	0.45	0.60	0.74	0.89	1.04	1.19	1.34	1.49
10.0 mm ²	0.09	0.18	0.27	0.36	0.44	0.54	0.63	0.71	0.80	0.89

POWER CONSUMPTION IN VA AT 1 A										
NOMINAL CROSS SECTION	10 M	20 M	30 M	40 M	50 M	60 M	70 M	80 M	90 M	100 M
1.0 mm ²	0.36	0.71	1.07	1.43	1.78	2.14	2.50	2.86	3.21	3.57
2.5 mm ²	0.14	0.29	0.43	0.57	0.72	0.86	1.00	1.14	1.29	1.43
4.0 mm ²	0.09	0.18	0.27	0.36	0.45	0.54	0.63	0.71	0.80	0.89
6.0 mm ²	0.06	0.12	0.18	0.24	0.30	0.36	0.42	0.48	0.54	0.60
10.0 mm ²	0.04	0.07	0.11	0.14	0.18	0.21	0.25	0.29	0.32	0.36

EXAMPLE OF TRANSFORMER POWER AND LINE LENGTH			
SECONDARY CURRENT = 1 A WIRE = 0.75 MM ² CONVERTER POWER / CABLE LENGTH		SECONDARY CURRENT = 5 A CABLE = 2.5 MM ² CONVERTER POWER / CABLE LENGTH	
CLASS 0.5	CLASS 1	CLASS 0.5	CLASS 1
0.5 VA / 5 m	0.5 VA / 5 m	0.5 VA / 0.7 m	0.5 VA / 0.7 m
1 VA / 15 m	1 VA / 15 m	1 VA / 2.1 m	1 VA / 2.1 m
2.5 VA / 47 m	1.5 VA / 26 m	2.5 VA / 6 m	2.5 VA / 6 m
5 VA / 100 m	2.5 VA / 47 m	5 VA / 13 m	5 VA / 13 m
10 VA / 205 m	5 VA / 100 m		10 VA / 27 m
	10 VA / 200 m		20 VA / 55 m
	20 VA / 400 m		

SERIES CONNECTION OF MEASUREMENT DEVICES TO A CURRENT TRANSFORMER

$P_v = U_{MG\ 1} + U_{MG\ 2} + \dots + P_{Line} + P_{Terminals} \dots?$

PARALLEL OPERATION / SUMMATION CURRENT TRANSFORMER

If the current measurement is made using two current transformers (e.g. 2 transformers), the total ratio of the current transformers must be programmed in the device. When measuring via summation current transformers, the same phase must be used.

Example: Both current transformers have a ratio of 1,000 / 5A. The summation measurement is performed with a summation current transformer 5+5/5 A.

The UMG must then be set as follows:

Primary current: 1000 A + 1000 A = 2000 A
 Secondary current: 5 A (with a measured 2,000 A, 5 A are output on the secondary side)

CURRENT TRANSFORMER GROUNDING

In connection with the increased use of electronic measuring systems – in accordance with the transformer standard DIN EN 61869 – grounding for transformers of nominal voltages of 0.72 kV and 1.2 kV is no longer required, nor is it prohibited. Grounding usually results from the functional design of the measuring systems. However, grounding can be done at the S1(k) terminal or S2(k) terminals. Important: always ground on the same side and only on one side!

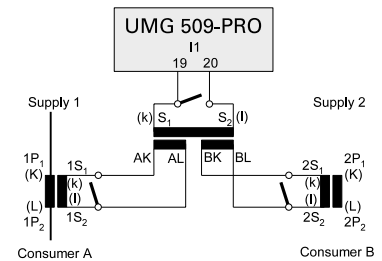

Fig.: UMG 509-PRO current measurement summation transformer

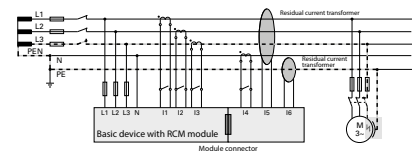

Fig.: Connection example for residual current monitoring with a UMG 96-PA basic device with module

OPERATION OF CURRENT TRANSFORMERS

OPERATION OF CURRENT TRANSFORMERS

Replacing a measurement device (short-circuiting of current transformers)

The current transformer secondary circuit should not be opened under any circumstances when current is flowing in the primary circuit.

The output of the current transformer represents a current source. Therefore, as the load increases, the output voltage increases (according to the relationship $U = R \times I$) until saturation is reached. Above saturation, the peak voltage continues to rise with increasing distortion and reaches its maximum value at infinite load, i.e. open secondary terminals. This means that on an open transformer, high voltage peaks can occur which pose a danger to people and can destroy the transformer as well as the measurement device when reconnecting. It follows that open operation must be avoided and the transformer must be short-circuited on the secondary side for safety reasons.

CURRENT TRANSFORMER TERMINAL BLOCK WITH SHORT-CIRCUIT DEVICES

Special terminal strips for DIN rails are recommended for short-circuiting current transformers and for purposes of recurring comparative measurement. These consist of a cross disconnect terminal with measuring and test equipment, insulated bridges for grounding and short circuiting the transformer terminal.



Fig.: Current transformer terminal strip

OVERLOAD

Primary current overload:

Primary current too high → Saturation of the core material → Accuracy drops dramatically → Thermal transformer damage possible

Rated power overload:

Too many measurement devices or lines that are too long are connected to a transformer with its defined nominal power → Saturation of the core material → Secondary current becomes too small → Accuracy drops dramatically

INSTANCE OF A SHORT CIRCUIT

In the event of a short circuit, there is no longer a signal and the measurement device can no longer measure. Current transformers can (or must) be short circuited if no load (measurement device) is connected.

OPERATION WITH HARMONICS

Our transformers generally measure harmonics up to 2.5 kHz (50th harmonic), and many types also measure up to 3 kHz and even beyond. However, at higher frequencies, eddy current losses increase and thus so does heating. If the harmonics content becomes too great, current transformers with thinner sheets must be used.

However, it is not possible to make any general statement about a limit value for the harmonics content, since the heating depends on the core size, transformer surface (cooling), ambient temperature, ratio, etc.

OWN POWER REQUIREMENT OF UMGS, ENERGY METERS, MEASUREMENT DEVICES

MEASUREMENT DEVICE TYPE	POWER CONSUMPTION CURRENT MEASUREMENT INPUT IN VA
Analog ammeter	1.1
UMG 103-CBM / 604-PRO / 605-PRO	0.2
UMG 96RM	0.2
UMG 96RM-E	0.2
UMG 509-PRO	0.2
UMG 512-PRO	0.2
ECSEM Series Energy Meters	0.36

POWER CONSUMPTION OF UMG 96RM-E PER CURRENT INPUT	
UMG 96RM-E	0.2 VA
	+
4 meters of 2-wire cable, 2.5 mm ²	1.64 VA
	=
Gives the power consumption of the measurement device	1.84 VA

THE SPECIAL CASE: LARGE TRANSFORMER – LOW CURRENT

Tip:

Select a current transformer suitable for measuring a rated current of 50 A.

To divide the normal current of a current transformer by two, it is in fact sufficient to pass this current through the transformer twice.



Stromwandler 50 / 5 A, I_{max} = 50 A



Äquivalent zu einem Wandler 100 / 5 A, I_{max} = 50 A

COMMUNICATION VIA THE RS-485 INTERFACE

When it comes to cost-effective networking of measurement devices, the RS-485 interface with the Modbus RTU protocol is still the measure of all things. The simple topology structure, the insensitivity to EMC interference and the open protocol have characterized the combination of RS-485 with the Modbus RTU protocol for years. The complete name of the RS-485 standard is TIA / EIA-485-A. The last revision was in March 1998 and the standard was confirmed in 2003 with no changes whatsoever. The standard only defines the electrical interface conditions of the transmitters and receivers, but says nothing about the topology or the lines to be used. This information can be found either in the TSB89 "Application Guidelines for TIA / EIA-485-A" or in the application descriptions of the RS-485 driver module manufacturers such as Texas Instruments or Maxim. According to the OSI model (Open Systems Interconnection Reference Model)*, only the "physical layer" is described, but not the protocol. The protocol used may be freely selected, such as Modbus RTU, Profibus, BACnet, etc. The communication between the transmitter and receiver is wired via a shielded twisted pair cable. Only one pair of wires should be used for A and B (Fig.: image 1a). If the interface is not galvanically isolated, the common connector must also be used (Fig.: image 1b). More on this later.

The data is transmitted by a differential, serial voltage level between lines [A] and [B]. Since data is transmitted on the lines between the transmitter and receiver, this is also referred to as half-duplex or alternating operation. Each receiver or transmitter has an inverting and non-inverting port. The transmission of the data is symmetrical. That is, if one line has a "high" signal, the other line has a "low" signal. Line A is thus the complement of B and vice versa. The advantage of measuring the voltage difference between A and B is that common-mode interference has almost no influence. Any common-mode interference is coupled in approximately equally on both signal lines, and due to the differential measurement, they therefore have no influence on the data to be transmitted. The transmitter (driver) generates a differential output voltage of at least 1.5 V into a 54 Ω load. The receiver has a sensitivity of +/-200 mV (Fig. image 2).

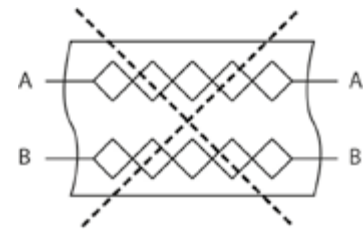

Fig.: Figure 1a

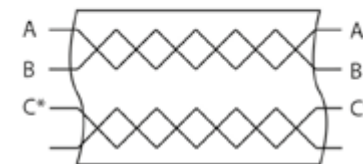

Fig.: Figure 1b

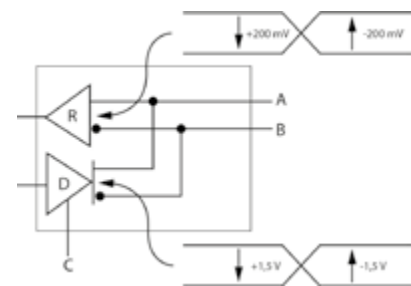

Fig.: Figure 2

THE LOGIC HERE IS AS FOLLOWS (FIG. IMAGE 3):

A-B < 0.25 V = logical 1
A-B > 0.25 V = logical 0

The labeling of the ports A/B is often not uniform. What is A for one manufacturer may be B for the next. Why is that?

THE DEFINITION SAYS:

A = "-" = T x D - / R x D - = inverted signal
B = "+" = T x D + / R x D + = non-inverted signal

A third line "C" = "Common" is also specified.
This line is for the reference ground.

** Open Systems Interconnection Reference Model (OSI): Driver = Transmitter; Receiver = Receiver; Transceiver = Transmitter / Receiver*

However, some RS-485 chip manufacturers such as Texas Instruments, Maxim, Analog Devices, etc. have used a different designation since the beginning, which is now also common:

A = "+" = T x D + / R x D + = non-inverted signal
B = "-" = T x D - / R x D - = inverted signal

Due to this confusion, some device manufacturers have introduced their own designation:

D+ = "+" = T x D + / R x D + = non-inverted signal
D- = "-" = T x D - / R x D - = inverted signal

The designation [+] and [-] after the letter [D] clearly shows which line represents the inverted and the non-inverted signal.

Janitza electronics GmbH mainly uses transceiver ICs from Texas Instruments, Analog Devices or Maxim. For this reason, all our measurement devices have the following designation:

A = "+" = T x D + / R x D + = non-inverted signal
B = "-" = T x D - / R x D - = inverted signal

THE VOLTAGES ARE DEFINED IN THE DATA SHEETS AS FOLLOWS:

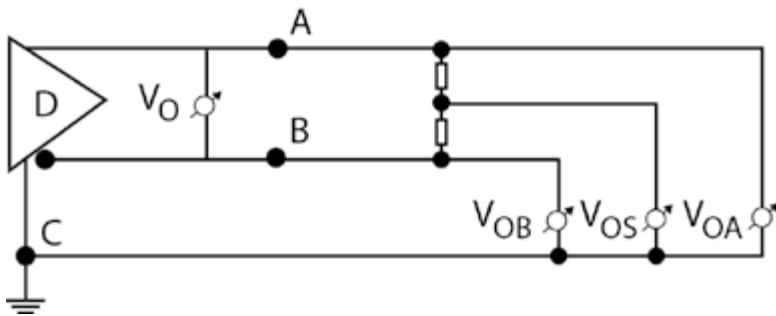

*V_O = Differential voltage A - B
V_{OB} = Voltage between B and C
V_{OA} = Voltage between A and C
V_{OS} = Driver offset voltage*

Fig.: Figure 4

THE VOLTAGE VCM

The voltage VCM (Common Mode Voltage) is the sum of the GND potential differences between the RS-485 nodes (Fig.: image 5), the driver offset voltage and the common mode noise voltage (V_{noise}) acting on the bus line. The RS-485 driver manufacturers specify a voltage range of -7 to 12 V for VCM. In case of communication problems, this voltage range is often violated due to potential differences between transmitter and receiver if the interface is not galvanically isolated or no common line exists. Figure 6 shows the calculation of the "Common mode" voltage.

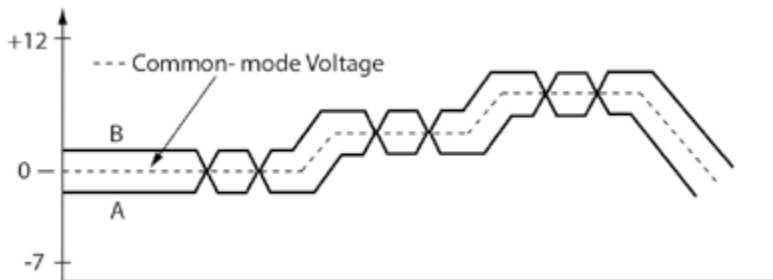

$$V_{OS} = \frac{V_{OA} + V_{OB}}{2}$$

Fig.: Figure 5

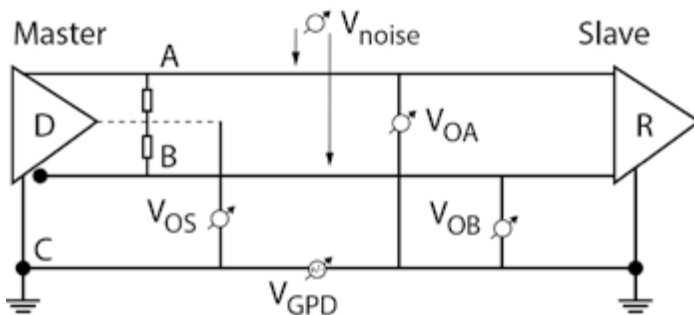

$$V_{CM} = V_{OS} + V_{noise} + V_{GPD}$$

Fig.: Figure 6

V_{GPD} (Ground potential differences)

V_{GPD} is the potential difference between transmitter and receiver GND (PE). Potential differences between the connections (grounds) often occur when the RS-485 bus is very extensive spatially. These potential differences occur especially in older electrical installations, because often there is no meshed potential equalization. Furthermore, especially in the event of lightning influences, the potential difference between the PE connections in the distributions can become hundreds or thousands of volts. Even under normal conditions, potential differences of a few volts may exist due to compensating currents of the consumers. Vnoise (common mode noise) is an interference voltage that can have the following causes:

- Interference voltage induced by a magnetic field on the bus line

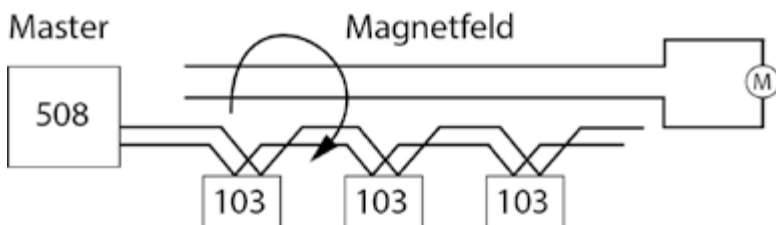

Fig.: Figure 7

- Capacitive coupling for system parts that are not galvanically isolated ("parasitic capacitances")

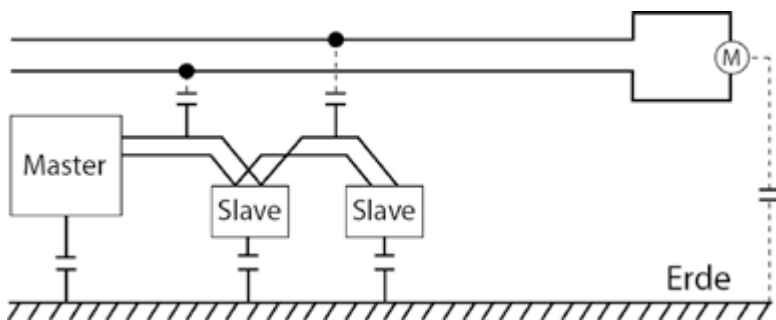

Fig.: Figure 8

- Galvanic coupling
- Radiant coupling
- Electrostatic discharge

BUS TOPOLOGY

The bus is "multipoint-capable", and up to 32 stations can be connected without a repeater. The best network topology is "daisy chain". This means that the bus cable goes directly from slave to slave.

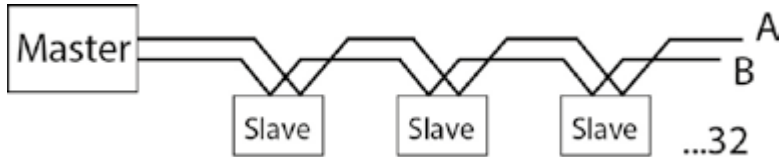

Fig.: Figure 9

It should be noted that stub lines should generally be avoided. Stub lines cause reflections on the bus. Theoretically, a possible stub line could be calculated in dependence on the transceiver used, but this is too complex in practice. The length of a possible stub depends strongly on the signal rise time of the transceiver used and should be smaller than 1/10 of the signal rise time of the driver. The higher the possible baud rates of the transceiver, the smaller the signal rise times of the driver. This means that you need to know which IC has been installed in the bus stations. In addition, the signal speed of the cable is also included in the calculation. For this reason, you should generally avoid stub lines.

TERMINATION

Another cause of communication interference is bus reflections. A reflection occurs when the transmitter signal is not completely absorbed by the load. The source impedance should be the same as the load impedance and the line characteristic impedance, as this will provide full signal power and minimize reflections. RS-485 serial communication works most efficiently when the source and load impedance are matched at 120 ohms. For this reason, the RS-485 standard recommends a bus line with a line characteristic impedance of $Z_0 = 120 \Omega$. To avoid reflections on the bus, the bus line must be provided with a termination resistor at the beginning and at the end which corresponds to the line characteristic impedance.

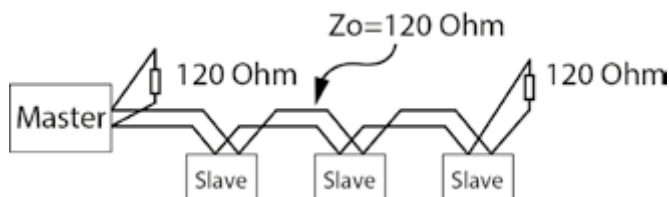

Fig.: Figure 10

"FAILSAFE BIAS" RESISTORS

If the receiver inputs are in the range of -200 mV to $+200\text{ mV}$, the output of the receiver module is undefined, i.e. no evaluation of the RS-485 signal can take place.

THIS IS THE CASE UNDER THE FOLLOWING CONDITIONS:

- No transmitter is active
- The bus line has been interrupted (e.g. line break)
- The bus line is short-circuited (e.g. line damaged etc.)

Under these conditions, the RS-485 bus must be brought into a defined signal state. Some communication buses do not have these problems, because here, for example, there is only one transmitter which controls the line. Either the transmitter is active or it is not. With the RS-485 bus, however, since it is multipoint capable, a number of transmitters can be connected.

To make the signal state unambiguous under the above conditions, one usually uses a "pull up" resistor between $+5\text{ V}$ and signal line A and a "pull down" resistor between GND and signal line B. The resistors can theoretically be placed anywhere on the bus, but are usually placed near the master in a voltage divider network with a termination resistor, since ready-made connectors are available for this purpose.

Some manufacturers only recommend installing a termination resistor at the beginning and at the end to avoid reflections (see the section Termination or Bus structure UMG 604-PRO with UMG 103-CBM). Why is that?

In this case, the manufacturers have used transceivers for the RS-485 interface that already have an internal failsafe bias built into the chip, i.e. at 0 V at the receiver input, the output automatically has a logical "high" state, for example. With Maxim (as used in the UMG 604-PRO and UMG 103-CBM) the function is called " ". An external failsafe bias is then only necessary if stations that do not have this function are connected to the same bus. Incidentally, the bus load is not affected by the "True fail-safe" function.

THE "COMMON CONNECTION" OR "GALVANICALLY ISOLATED"

The bus stations usually obtain their supply voltage from different areas of the electrical installation. Particularly in older electrical installations, this can result in considerable potential differences between the groundings. For error-free communication, however, the voltage V_{cm} must only be in the range of -7 to +12 V, i.e. the voltage V_{GPD} (ground potential differences) must be as small as possible (Fig. 11 a, Fig. 5). If the RS-485 interface is not galvanically isolated from the supply voltage, the common connection must be included (Fig. 11 b). However, the connection of the common terminals can result in a current loop, i.e. without an additional measure, a high equalizing current flows between the bus stations and the grounding. This is usually prevented by the developers by decoupling the GND of the RS-485 interface from the ground by a 100 ohm resistor (Fig. 11 c).

A better alternative is the galvanic isolation of the RS-485 interface from the supply voltage by an internal DC/DC converter and a signal isolator. Potential differences in the grounding then have no influence on the signal. The differential signal thus "floats". Better yet is the galvanic isolation of the RS-485 interface in combination with a common connection.

Figure 12 shows a mixed operation between stations with galvanically isolated and non-isolated interfaces. The stations with galvanically isolated RS-485 interfaces have no common connection in the example. In this case, make sure that the common ports of the subscribers are connected to each other. Nevertheless, communication interference may occur due to EMC coupling capacitors. This results in the non-galvanically isolated stations no longer being able to interpret the signal. In this case, the bus must be separated and an additional galvanic coupling must be integrated between the station circuits.

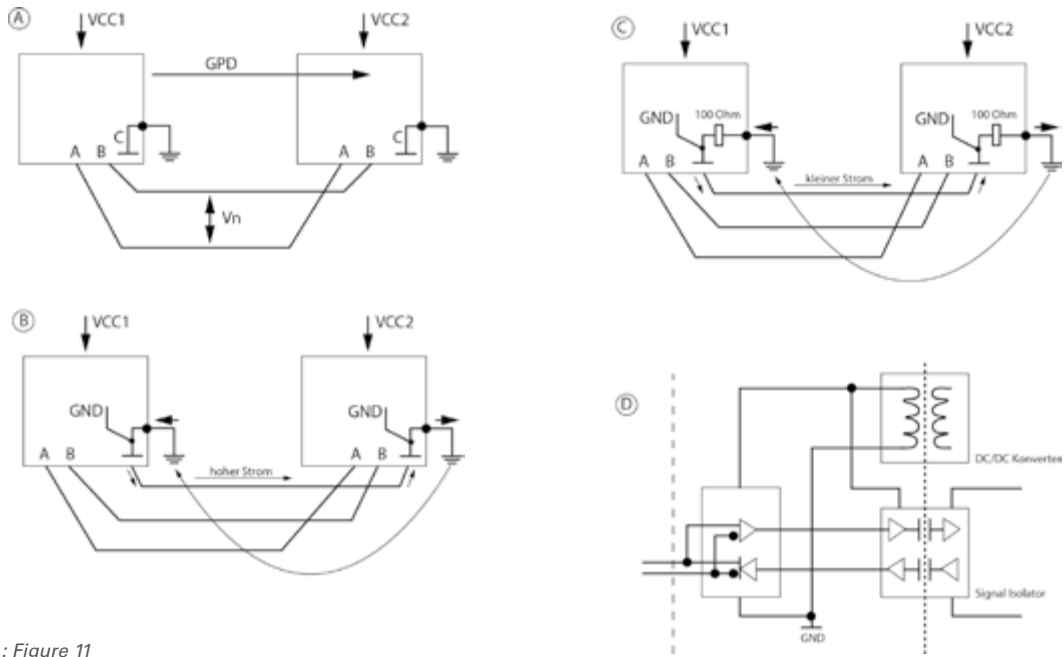

Fig.: Figure 11

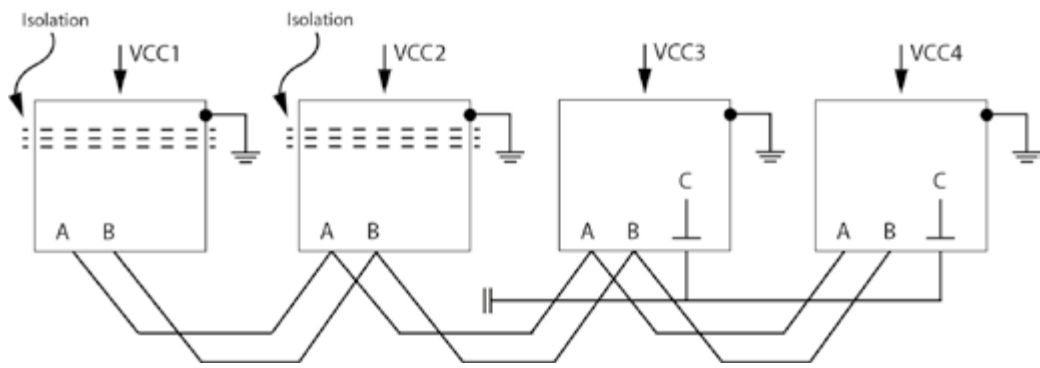

Fig.: Figure 12

Note: The shielding must never be connected to the common connector of the RS-485 interface. This would couple interference directly into the GND of the RS-485 transceivers.

ANALYSIS AND OPTIMIZATION OF RS-422 AND RS-485 BUS SYSTEMS

OUR RECOMMENDATION: MSB-RS-485 ANALYZER – THE PERFECT COMBINATION OF HARDWARE AND SOFTWARE ANALYSIS

- Independent analyzer device, controlled and powered via USB
- Fast realtime signal/data processing via hardware
- Provides data on any line change with microsecond accuracy
- Equipped with a variety of visualization tools, it allows a detailed view into any RS-422/485 communication system
- Detects bus-enable errors, timeouts, or incorrect/duplicate addressing
- Variable connection types allow the complete logging of all bus activities as well as the targeted recording of data sent by selected bus stations
- HV-side independent time recording of all events with 1 μ s resolution
- Simultaneous display of both the tri-state signal levels and the transmitted data
- Detection of inactive bus states and invalid line levels
- Measurement and use of ALL baud rates from 1..1 MBaud
- Automatic acquisition of baud rate, data bits and parity
- Supports 9-bit data word protocols



Available from www.iftools.com

PORTS, PROTOCOLS AND CONNECTIONS

UMG 604-PRO / UMG 605-PRO	
PROTOCOLS	PORTS
TFTP	1201
Modbus / TCP – Modbus / UDP	502, 4 ports
DHCP	68
NTP	123
BACnet	47808
Name service	1200
HTTP	80
FTP	21
FTP data port	1024, 1025
FTP data port	1026, 1027
Modbus via Ethernet	8000, 1 port
Service port (Telnet)	1239
SNMP	161 / 162 (TRAP)
Email port (current)	25
Email port (being prepared)	587

UMG 103-CBM	
PROTOCOLS	PORTS
Device does not have an Ethernet port	Device does not have an Ethernet port

GridVis®	
PROTOCOLS	PORTS
Modbus / TCP – Modbus / UDP	502
HTTP	80
FTP	21
FTP data port	1024, 1025
FTP data port	1026, 1027
Modbus / TCP	502
Modbus via Ethernet	8000
Read out Telnet data port	1239
Update Telnet data port	1236, 1237
Email port (preparation)	25
Email port (preparation)	587

NUMBER OF TCP/UTP CONNECTIONS (UMG 604-PRO / 605-PRO)

- A total of max. 24 connections are possible via the TCP group.
 - The following points apply:
 - Port 21 (FTP): max. 4 connections
 - Port 25/587 (e-mail): max. 8 connections
 - Port 1024-1027 (data port to any FTP port): Max. 4 connections
 - Port 80 (HTTP): max. 24 connections
 - Port 502 (Modbus TCP/IP): Max. 4 connections
 - Port 1239 (debug): max. 1 connection
 - Port 8000 (Modbus or TCP/IP): max. 1 connection
- Connectionless communication via the UTP group
 - Port 68 (DHCP)
 - Port 123 (NTP)
 - Port 161/162 (SNMP)
 - Port 1200 (name service)
 - Port 1201 (TFTP)
 - Port 47808 (BACnet)

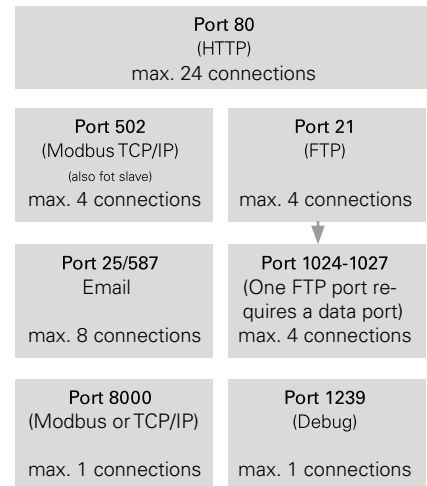

Fig.: TCP group: max. 24 connections (queue scheduling) (UMG 604-PRO / 605-PRO)

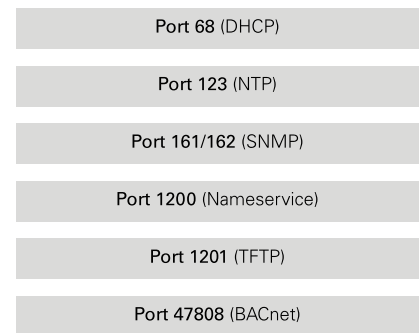

Fig.: UTP group: connectionless communication (UMG 604-PRO / 605-PRO)

The UMG 96RM-E supports the following protocols via Ethernet connection

CLIENT SERVICES	PORTS
DNS	53 (UDP / TCP)
DHCP client (BootP)	68 (UDP)
NTP (client)	123 (UDP)
Email (send)	Selectable (1-65535 TCP)
SERVER SERVICES	PORT
Ping	(ICMP / IP)
FTP	20 (TCP)*, 21 (TCP)
HTTP	80 (TCP)
NTP (listen only)	123 (UDP broadcast)
SNMP	161 (UDP)
Modbus TCP	502 (UDP / TCP)
Devices identification	1111 (UDP)
Telnet	1239 (TCP)
Modbus RTU (Ethernet encapsulated)	8000 (UDP)

* Random port (> 1023) for data transmission if working in PASSIVE mode.

The UMG 96RM-E can manage 20 TCP connections.

Client services are contacted by the device to a server via the specified ports; server services are provided by the device.

The following protocols are not supported.

BACnet (47808 / UDP)

PREREQUISITE AND CONFIRMATION FOR COMMISSIONING (VBI)

GENERAL

The Prerequisites and Confirmation for Commissioning (VBI) serves the purpose of preparation and preliminary information for commissioning by Janitza electronics GmbH. A confirmation of the correct electrical installation as well as the technical prerequisites for the installation of the software is required before commissioning.

ELECTRICAL INSTALLATION OF JANITZA MEASUREMENT DEVICES IN GENERAL

- **Access:** All devices must be fully functional (auxiliary voltage, connection etc.) with unhindered access to interface, connection and display.
- **Interfaces:** The bus connection of the devices to each other and to the PC must be properly and functionally wired. Information on the connection of the interfaces and wiring can be found in the associated operating manual.
- **Wiring:** No stub line has been created on the RS-485 interface (see graphic). That is, all devices have been connected to the power analyzer in series.
- **Bus cable:** A bus cable has been used for the RS-485 wiring. The cable must be shielded and the wires (A&B) must be twisted together. We recommend the following bus cable: Li2YCY(TP)2x2x0.22).
- **Master:** The following structure has been adhered to in the bus lines: The master (UMG 604-PRO / UMG 605-PRO / UMG 96RM-E) is the first station on the bus.
- **RS-485:** For the UMG 604-EP, UMG 605-PRO, UMG 96RM-P, UMG 509-PRO and UMG 512-PRO, the necessary Profibus connector for the RS-485 interface has been used. The Profibus connector is mandatory because the RS-485 interface is designed for the internal termination resistor.
- **Setup plan:** A setup plan of the bus connections for all stations must have been given to the responsible technician in advance by email or fax (support@janitza.de).

- **Transformer setting:** The CT settings must have been made by the customer. If setting the transformers is part of the commissioning (see specifications), a device list with name-related transformer data must be given to the responsible technician in advance.
- **IP addresses:** The device names and IP addresses must be defined and documented and must be given to the responsible technician before commissioning.
- **Settings:** For measurement devices with an Ethernet connection, the IP addresses must be assigned. If setting the IP address is part of the commissioning (see specifications), a device list with IP address, subnet mask and gateway must be given to the responsible technician in advance.
- **Termination resistor:** A 120 Ω termination resistor must be set at the beginning and end of a bus line between A and B. Devices with a Profibus connector must be switched ON.
- **Connection:** After connecting the measurement devices, the following measured values must be checked:
 - The active power of the individual phases should be positive. If this is not the case, there is a power feed or a faulty connection (k and l reversed)
 - The cos phi of the individual phases should be above a realistic value of 0.5 (guide value). If this is not the case, the phase assignments of the current and voltage measurement must be checked. The current and voltage connection must be assigned to the phases correctly.
- **Database:** The MySQL / MS SQL database must be installed and administered.

For commissioning, it is important that a local, responsible electrician / installer be on site during commissioning.

SOFTWARE INSTALLATION AND NETWORK ADMINISTRATION

The following points show the prerequisites as well as features of the GridVis® evaluation and configuration software (version 4) from Janitza electronics GmbH.

- **GridVis® license:** The activation of GridVis® requires an account on the Janitza ID server (<https://id.janitza.de>). The account should be created by the responsible person before commissioning. The Standard and Expert editions require an activation code. The activation code can be purchased from Janitza electronics GmbH. Internet access is required for activation.

■ **PC system requirements:**

- Current processor architecture: Intel Xeon recommended (server capable)
- RAM: Min. 8 GB (standard database), recommended: 16 GB (MySQL, MSSQL database)
- Installation memory: 2 GB
- 64-bit system
- Recommended and optimized screen resolution: 1280 x 960 pixels

■ **Supported web browsers:**

- Google Chrome (current version) - Recommended
- Microsoft Edge
- Firefox (current version)

■ **Supported operating systems:**

- Microsoft Windows Server 2008
- Microsoft Windows Server 2012
- Microsoft Windows Server 2016
- Microsoft Windows Server 2019
- Microsoft Windows 8
- Microsoft Windows 10
- Linux distributions on request and only for large-scale projects

- **Memory reserves:** The required storage capacity for data archiving depends on the number of measurement devices. About 500 MB of storage per year can be assumed for one measurement device. (Number of devices times 500 MB times archiving years).

- GridVis® Essentials is delivered with the Janitza database as standard.

- The installation / administration of the MySQL / MS SQL database is not included in commissioning. The following data must be given to the person who commissions the system:
- IP database
 - Port number
 - Name of the database
 - User and password

▪ GridVis® license model / software variants:

	GridVis® Essentials	GridVis® Standard	GridVis® Expert
SYSTEM FUNCTIONS			
Device configuration	•	•	•
Service	–	•	•
Logic	–	•	•
Automation	–	•	•
Database management	–	•	•
Device monitoring	–	•	•
Online recorder	–	•	•
User management	–	•	•
Active directory	–	–	•
Alarm management	–	–	•
VISUALIZATION			
Graph function	•	•	•
Device overview	•	•	•
Event browser	•	•	•
Dashboards & templates	–	•	•
Widget basic package	–	•	•
Widget enhancement	–	–	•
Sankey diagram	–	–	•
Key performance indicators (KPI)	–	–	•
DOCUMENTATION			
Basic data exports	•	•	•
RCM data exports	•	•	•
PQ data exports	–	•	•
EnMS & EEG data exports	–	•	•
Report editor	–	–	•
CONNECTIVITY			
CSV data import	–	•	•
MSCONS data import	–	•	•
REST API	–	•	•
Modbus devices from third party suppliers	–	–	•
OPC UA Client	–	–	•
Comtrade data exports	–	–	•
MSCONS data export	–	–	•

Further information about the GridVis® Editions can be found here:
<https://www.gridvis.com/gridvis-editions.html>



■ **Databases:**

- MSSQL – recommended:
MSSQL 2014, 2016, 2017 and 2019 are supported.
Express versions are not supported!
- MySQL (5.7.22 & 8.0.16)
- JanDB – included in the scope of delivery

■ **Database information:**

- The database users need read and write permissions
- The database structure is generated by GridVis® when the project is created
- To be able to create a project requires owner rights
- The user "root" or "SA" should not be used for GridVis® projects
- The database structure is open and documented

■ **Standard database:**

The Janitza DB as the standard database can only be used locally; multiple access is only possible locally (e.g. GridVis® service in the background and GridVis® Desktop on the same computer/server).

■ **Installation directories:**

The installation directory is freely selectable. If multiple users need access, the installation and the project must be located in a directory area where access rights are given to all users.

■ **Project directory:**

The project directory must be located only locally on the computer/server. It is not possible to place the project directory on a network drive.

■ **Port information:**

The following communication ports are required for data transfer between the measurement device and the software:

- HTTP 80
- FTP command port 21 (data port 1024, 1025, 1026, 1027)
- Modbus/TCP 502 (4 ports)
- NTP 123

The following communication ports could be used in addition:

- SNMP 161
- BACnet 47808

■ **Automatic memory readout:**

The GridVis® software versions have an automatic readout function as of GridVis® Standard which can be activated (installation of GridVis® Service).

▪ **GridVis® Service information:**

- Service instances can be installed as of the GridVis® Standard Edition.
- Automatic memory readout as of GridVis® Standard Edition and online readout as of GridVis® Expert Edition are taken over by the Service in the background.
- A Service instance supports the management of approx. 300 measurement devices
- The web server port of the Service instance can be changed during installation.
- The Service is managed by Windows and does not require a user to log in. During a restart, the Service is restarted as well.

▪ **Online readout:**

The GridVis® software offers a means for recording and archiving measured values online. This function can be used for measurement devices without a ring buffer (memory), for example. The polling time is configurable. Online readout is available as of the GridVis® Expert edition.

▪ **Server-client principle:**

Multiple access to a database depends on the database type. The Janitza database supports only local access. MySQL and MS SQL databases support multiple accesses. However, the read and write permission must be assigned to a GridVis® Desktop instance or a GridVis® Service instance.

▪ **NTP – Time synchronization:**

- Some Ethernet measurement devices have an NTP client for time synchronization. These meters support the following modes:
- Active (IP is addressed directly)
 - Listen (broadcast)

Time synchronization without an NTP server can be performed with the computer time as of the GridVis® Standard Edition.

▪ **Historical evaluation:**

A historical evaluation (time period evaluation) requires devices with a ring buffer (memory). An alternative is the GridVis® Expert Edition in which the online recording can be used for archiving.

Administrative rights are required for the installation during commissioning. Internet access should be available for the GridVis® activation. It is recommended that a responsible person from the IT department be present on site during commissioning to clarify any questions directly.

SPECIAL INFORMATION FOR THE ELECTRICAL INSTALLATION OF JANITZA MEASUREMENT DEVICES

If commissioning includes the ProData® 2 (consumption pulse recording), the following points must be noted:

■ **Special information on ProData® 2:**

For ProData® 2 (consumption data recording of water/heat quantities, etc.), the pulse valencies must be known before commissioning and must also be sent to the responsible technician in advance by e-mail.

Example: ProData® 2

Digital input 1 = outbuilding water meter = 1 m³ per pulse
Digital input 2 = main building heat meter = 1 kWh per pulse
etc.

INSTRUCTION

After commissioning, the operating personnel should be instructed concerning the GridVis® evaluation and configuration software. This briefing should take place on the computer that has been set up with access to all measurement points. The briefing includes the following topics:

- Software navigation
- Configuration of the measurement devices
- Evaluation of historical data (graph, reports)
- Creation of the topology
- Managing automatic readout / time setting

CONTENT OF THE COMMISSIONING (REQUIREMENT SPECIFICATION)

The commissioning tasks are clearly defined. Tasks that are not part of the standard commissioning must be included separately in the order. The number of measurement points to be included and the number of software instances to be installed must be defined before the commissioning.

- Number of measurement points
- Number of GridVis® Desktop instances
- Number of GridVis® Service instances

Standard commissioning tasks:

■ Installation:

Install current GridVis® software (create project, import project)

■ Configuration:

- Integration of all Janitza measurement points into the GridVis® software (connection configuration)
- Configure the device application specifically (pulse outputs, alarm outputs)
- Configure automatic readout / online readout
- Software / firmware update

■ Instruction on the GridVis® software:

- Device management
- Graph function
- Topology creation

Additional commissioning services:

■ Configuration:

- Make all CT settings
- Assign device addresses and IP addresses

■ Configuration:

- Create customer-specific topology
- Integrate customer-specific Jasic® programs
- Troubleshooting, support
- Creation of virtual measurement points

It is recommended that the responsible electrician / installer be present on site during commissioning in order to clarify any questions directly. In addition, it would be desirable for the operator of the system to be present for instruction. All points should be completed to ensure smooth commissioning.



INFORMATION





470 Logistics information

LOGISTICS INFORMATION

INDIVIDUAL PACKAGING						
TYPE	DIMENSIONS in mm (W x H x D)	NET EQUIPMENT WEIGHT in kg	GROSS EQUIPMENT WEIGHT in kg (ready for shipment: incl packaging and operating manual, etc.)	DEVICE TYPE	QUANTITY OF DEVICES IN THE PACKAGING	PART NO.
Individual packaging 1	180 x 85 x 145	0.3	0.4	UMG 96-S2	1	3101035
Individual packaging 1	180 x 85 x 145	0.5	0.6	UMG 96RM / -M, ProData®	1	3101035
Individual packaging 1	180 x 85 x 145	0.2	0.3	UMG 103-CBM	1	3101035
Individual packaging 2	180 x 140 x 170	0.4	0.8	UMG 96RM-P / -PN / -CBM / -E, UMG 96-PA / UMG 96-PQ-L	1	3101034
Individual packaging 2	180 x 140 x 170	0.3	0.8	UMG 604-PRO / UMG 605-PRO	1	3101034
Individual packaging 2	180 x 140 x 170	1.0	1.2	Prophi® / Prophi® 7	1	3101034
Individual packaging 2 ^{*1}	180 x 140 x 170	1.5	1.7	UMG 509-PRO / UMG 512-PRO / UMG 801	1	3101034

*1 This packaging is not suitable for individual shipment of the UMG 509-PRO, UMG 512-PRO and UMG 801; this is done with outer carton 1.

Packing carton sizes											
Type	Dimensions in mm (W x H x D)	Packaging weight in kg (outer carton / pallet)	Max. number of individual packaging 1 (see Tab. 1)	Total weight in kg with the respective device type* ³			Max. number of individual packaging 2 (see Tab. 1)	Total weight in kg with the respective device type* ³			
				UMG 96-S2	UMG 96RM / -M, ProData®	UMG 103-CBM		UMG 96RM-P / -PN / -CBM / -E, UMG 96-PA / UMG 96-PQ-L	UMG 604-PRO / UMG 605-PRO	Prophi® / Prophi® 7	UMG 509-PRO / UMG 512-PRO / UMG 801
				1	2	3		4	5	6	7
Outer carton 1	315 x 190 x 225	0.2	4	1.4	1.9	1.1	2	1.9	1.6	2.7	3.3
Outer carton 2	400 x 250 x 300	0.4	10	4.2	6.0	3.4	4	5.0	3.5	5.9	6.9
Outer carton 3	340 x 280 x 240	0.3	8	3.3	4.8	2.7	4	4.1	3.4	5.0	6.8
Outer carton 4	400 x 550 x 240	0.8	18	7.7	11.0	6.3	8	8.5	7.1	10.3	13.9
Outer carton 5	440 x 390 x 395	0.9	26	10.8	15.5	8.7	12	12.4	10.3	15.1	20.4
Outer carton 6	700 x 400 x 400	1.4	40	16.6	23.8	13.4	20	20.5	17.0	25.1	33.8
Outer carton 7	800 x 400 x 400	1.5	46	19.0	27.3	15.3	20	20.6	17.1	25.1	33.9
Outer carton 8 On one-way pallet* ²	800 x 400 x 600	7.3	72	34.6	47.6	28.9	34	39.6	33.8	47.4	62.6
Outer carton 9 On one-way pallet* ²	1180 x 905 x 780	14.8	280	123.1	175.4	102.6	128	140.2	118.4	169.7	226.0

*1 This packaging is not suitable for individual shipment of the UMG 509-PRO, UMG 512-PRO and UMG 801; this is done with outer carton 1.

Packaging sizes, cardboard box for 10-device project packaging (Part No.: 3101040)

Shipping package				Total weight in kg with the respective device type		
Type	Dimensions in mm (W x H x D)	Max. number of pieces	10% accessories (pcs.) Manual	UMG 96-S2	UMG 96RM / -M, ProData®, UMG 96-PA, UMG 96-PO-L	UMG 103-CBM
Outer carton 4	400 x 550 x 240	40 (4 x 10 pcs.)	4	12	14	8
Outer carton 5	440 x 390 x 395	60 (6 x 10 pcs.)	6	17	21	12
Outer carton 6	700 x 400 x 400	90 (9 x 10 pcs.)	9	26	31	17
Outer carton 8 On one-way pallet*1	800 x 400 x 600	150 (15 x 10 pcs.)	15	49	57	34
Outer carton 9 On one-way pallet*1	1180 x 905 x 780	840 (84 x 10 pcs.)	84	260	305	176

– Dimensions, 10-device project packaging (W x H x D in mm): 225 x 105 x 315.

– Only devices of the same type can be supplied in the project packaging.

– Project packages include 100% patch cables and 10% other accessories! Mounting kits are enclosed 100% device-specific.

*1 One-way pallets are IPPC certified.

Packaging sizes, cardboard box for 12-device project packaging (Part No.: 3101042)

Shipping package				Total weight in kg with the respective device type		
Type	Dimensions in mm (W x H x D)	Max. number of pieces	10% accessories (pcs.) Manual, crossover cable	UMG 96RM-CBM / -P	UMG 96RM-E / 96RM-PN UMG 96-PA / UMG 96-PO-L	UMG 604-PRO / UMG 605-PRO
Outer carton 4	400 x 550 x 240	24 (2 x 12 pcs.)	3	11	12	10
Outer carton 5	440 x 390 x 395	36 (3 x 12 pcs.)	4	17	17	15
Outer carton 8 On one-way pallet*1	800 x 400 x 600	96 (8 x 12 pcs.)	10	50	51	45
Outer carton 9 On one-way pallet*1	1180 x 905 x 780	468 (39 x 12 pcs.)	47	235	238	210

– Dimensions 12-unit project packaging with foam inserts (W x H x D in mm): 450 x 150 x 330.

– Only devices of the same type can be supplied in the project packaging.

– Project packages include 100% patch cables and 10% other accessories! Mounting kits are enclosed 100% device-specific.

*1 One-way pallets are IPPC certified.

INDEX

FRONT PANEL INSTALLATION MEASUREMENT DEVICES

UMG 509-PRO		Page 80
UMG 512-PRO		Page 88
UMG 96-PA series		Page 42
UMG 96-PQ-L		Page 70
UMG 96RM series		Page 34
UMG 96RM-E		Page 62
UMG 96-S2		Page 28

HUTSCHIENEN-MESSGERÄTE

MID Energy Meters		Page 166
RCM 201-ROGO		Page 162
RCM 202-AB		Page 156
UMG 103-CBM		Page 108
UMG 20CM		Page 146
UMG 604-PRO		Page 132
UMG 605-PRO		Page 140
UMG 801		Page 114
UMG 806		Page 98

INDEX

OPERATING CURRENT TRANSFORMER

Plug-in current transformer		Page 188
Plug-in current transformers for billing purposes		Page 194
Three-phase current transformers		Page 210
Flexible current transformers		Page 220
DIN rail current transformers with voltage tap-off & back-up fuse		Page 212
Split core current transformers		Page 204
Split-core current transformers		Page 216
Small-signal transformers		Page 198
Compact current transformers		Page 214
Summation current transformers		Page 200
Separable operating current transformers up to 600 A		Page 218
Separable residual current transformer		Page 208

INDEX

RESIDUAL CURRENT TRANSFORMER

6-fold DIN rail current transformer		Page 244
Plug-in residual current transformer		Page 234
Residual current transformer, Type A		Page 236
Residual current transformer, Type B+		Page 232
Compact current transformer for the UMG 20CM		Page 240
Split-core current transformer		Page 242
Separable residual current transformer	 	Page 230

RESIDUAL CURRENT TRANSFORMER ACCESSORIES

Humidity and temperature sensor JFTF-I		Page 251
Voltage tap-offs	  	Page 248
Current transformer terminal strip		Page 250

INDEX

ACCESSORIES





Adapter for DIN rail mounting		Page 268
D-SUB bus connector		Page 258
Fieldbus modules, FBM series		Page 266
GPS radio receivers		Page 264
Gateway M-BUS-GEM		Page 256
K-7510: RS-485 repeater, isolated		Page 259
K-7513: RS-485 to 3 x RS-485 hub		Page 260
EasyGateway V50 LTE modem		Page 254
PowerToStore		Page 257
Switching power supply for DIN rail mounting		Page 262
Switching power supply with stepped/circuit-breaker design		Page 263
USB/RS-485 converter cable		Page 261

INDEX

MEASUREMENT DATA ACQUISITION

JPC 100-WEB		Page 282
ProData		Page 276

SOFTWARE

APPs	APPs	Page 332
Database Server		Page 326
GridVis®	GridVis®	Page 290
GridVis® Cloud	GridVis® Cloud	Page 306
GridVis® Collector		Page 316
Jasic®	Jasic®	Page 346
Device Homepage		Page 344
Multiprotocol Server		Page 322

The contents, performance features and diagrams provided in this catalogue are not always reflective of the actual case in their described form and may also be subject to change due to ongoing product developments. The text and images contained herein have been generated with due care and diligence. However, it is not possible to fully exclude errors from arising. The desired performance features are only binding if these are expressly agreed upon conclusion of the contract. Subject to technical change and delivery amendments.

The trade names, brand names and trade descriptions etc. provided in this catalogue are subject to the guidelines of the respective manufacturer.

Janitza electronics GmbH does not guarantee to keep this catalogue up-to-date.

Further up-to-date information can be found at www.janitza.com

The General Terms and Conditions (GTCs) of Janitza electronics GmbH can be found at <https://www.janitza.com/standard-terms-and-conditions.html>

Janitza electronics GmbH
Vor dem Polstück 6 | 35633 Lahnau
Germany

Tel.: +49 6441 9642-0
info@janitza.com | www.janitza.com

Sales partner

Item no.: 3303753 • Doc. no.: 25000829j • 01/2023 • Subject to technical alterations.
The latest version of the brochure is available at www.janitza.com