

Power Analyser

**UMG 96-PA<sup>MID</sup>**

Data sheet

# DEVICE VIEWS

Front view

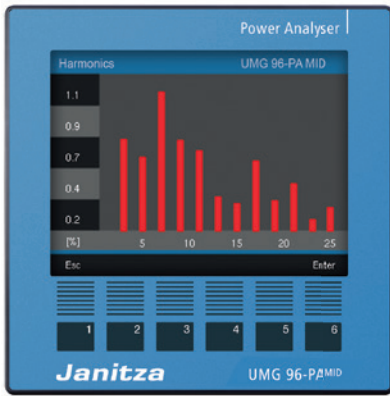

Rear view

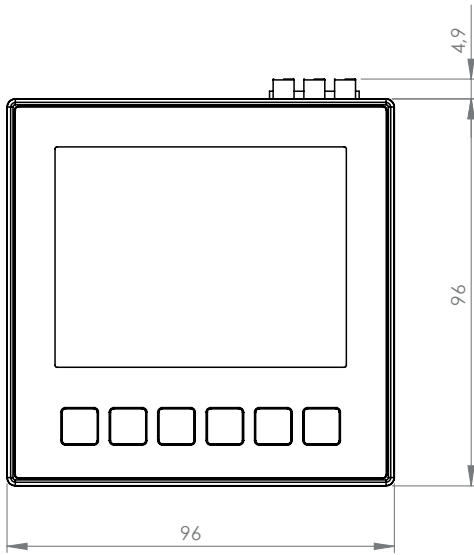
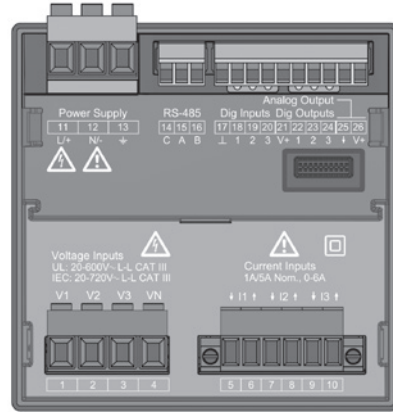

Side view

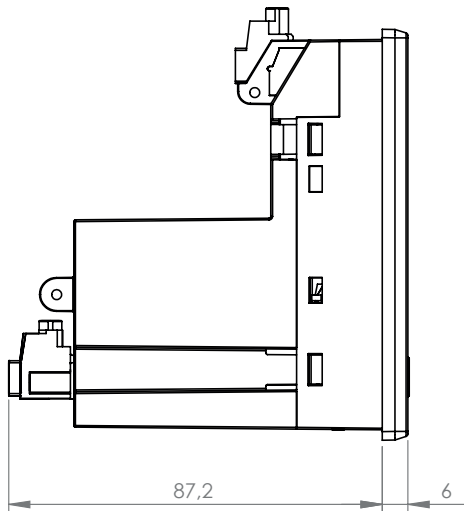

Bottom view

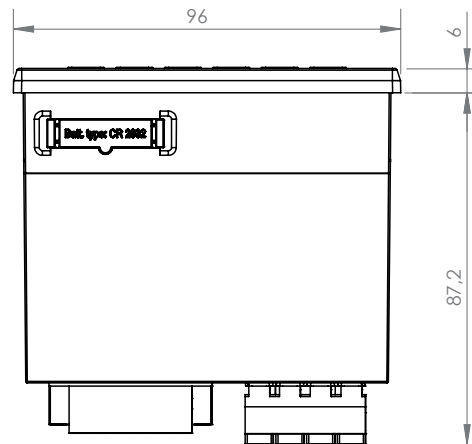

Cut-out size: 92<sup>+0,8</sup> mm x 92<sup>+0,8</sup> mm.

All dimensions in mm

# TECHNICAL DATA

General information	
Net weight (with attached connectors)	Approx. 250 g
Packaging weight (including accessories)	Approx. 500 g
Battery	Type Lithium CR2032, 3 V (approval according to UL 1642)
Service life of the background lighting	40000 h (background lighting is reduced to approx. 50% for this period)

Transport and storage	
The following information applies to devices that are transported or stored in the original packaging.	
Free fall	1 m
Temperature	-25 °C to +70 °C
Relative humidity (non-condensing)	0 to 90% RH

Ambient conditions during operation	
Use the device in a weather-protected, stationary application. Protection class II in accordance with IEC 60536 (VDE 0106, Part 1).	
Measurement temperature range	-10 °C .. +55 °C
Relative humidity (non-condensing)	0 to 75 % RH
Operating altitude	0 .. 2000 m over NN
Pollution degree	2
Installation position	discretionary
Ventilation	No external ventilation required.
Protection against foreign bodies and water	
- Front	IP40 according to EN60529
- Rear	IP20 according to EN60529
- Front side with sealing	IP54 according to EN60529 (required for the MID device!)
Electromagnetic ambient conditions	Class E2 (MID 2014/32/EU)
Mechanical ambient conditions	Class M1 (MID 2014/32/EU)

Supply voltage	
Nominal range	AC 90 V - 277 V (50/60 Hz) or DC 90 V - 250 V, 300 V CATIII
Power consumption	Max. 4.5 VA / 2 W
Operating range	+/-10% of nominal range
Internal fuse, not interchangeable	Type T1A / 250 V DC / 277 V AC according to IEC 60127
Recommended overcurrent protection device for the line protection (approval according to UL)	Option 230 V: 6 - 16 A (Char. B)

Recommendation for the maximum number of devices on one circuit breaker:  
Circuit breaker B6A: 4 devices max. / circuit breaker B16A: 11 devices max.

<b>Voltage measurement</b>	
Three-phase 4 conductor systems with rated voltages up to	230/400 V <sup>1)</sup> (MID)
Single-phase 2 conductor systems with rated voltages up to	230 V
Overvoltage category	600 V CAT III
Measurement voltage surge	6 kV
Fuse for the voltage measurement	1 - 10 A (with IEC/UL approval)
Measuring range L-N	0 <sup>2)</sup> .. 600 V <sub>rms</sub> (max. overvoltage 800 V <sub>rms</sub> )
Measuring range L-L	0 <sup>2)</sup> .. 1040 V <sub>rms</sub> (max. overvoltage 1350 V <sub>rms</sub> )
Resolution	0.01 V
Crest factor	2.45 (related to the measurement range)
Impedance	3 M $\Omega$ /Phase
Power consumption	Approx. 0.1 VA
Sampling frequency	8.33 KHz
Frequency of the basic oscillation - resolution	45 Hz .. 65 Hz 0.01 Hz
Reference frequency	50 Hz

- 1) Voltage measurement without measuring transformers only possible up to 300 V.  
 2) The device only determines the measured values if voltage L1-N is greater than 20 V<sub>eff</sub> (4-conductor measurement) or voltage L1-L2 is greater than 34 V<sub>eff</sub> (3-conductor measurement) on voltage measurement input V1

<b>Current measurement</b>	
Rated current	5 A
Metering range	0.002 .. 6 A <sub>rms</sub>
Crest factor (based on the rated current)	2 (based on 6 A <sub>rms</sub> )
Overvoltage category	300 V CAT II
Measurement voltage surge	2 kV
Power consumption	Approx. 0.2 VA (R <sub>i</sub> =5 m $\Omega$ )
Overload for 1 sec.	60 A (sinusoidal)
Resolution	0.1 mA (Display 0.01 A)
Sampling frequency	8.33 KHz

<b>Active Energy (MID)</b>	
Accuracy class	B according to DIN EN 50470-1

<b>Serial interface</b>	
RS485 - Modbus RTU/Slave	9.6 kbps, 19.2 kbps, 38.4 kbps, 57.6 kbps, 115.2 kbps

<b>Digital outputs</b>	
3 digital outputs, semiconductor relays, not short-circuit proof.	
Switching voltage	Max. 33 V AC, 40 V DC
Switching current	Max. 50 mA <sub>eff</sub> AC/DC
Response time	Approx. 200 ms
Pulse output	Max. 50Hz (energy pulse)
Pulse value S0 (pulse constant)	10,000 pulses/kWh <sup>1)</sup>

UMG 96-PA<sup>MID</sup>: The „Active energy“ measured value (obtained/supplied) occupies digital output 1 (terminal 21/22).

- 1) The pulse value S0 is automatically adjusted to the set voltage transformer ratio. The current pulse value S0 appears in the active energy measured value indication

<b>Digital inputs</b>	
3 digital inputs, semiconductor relays, not short-circuit proof.	
Maximum counter frequency	20 Hz
Input signal present	18 V .. 28 V DC (typical 4 mA)
Input signal not present	0 .. 5 V DC, current less than 0.5 mA

<b>Line length (digital inputs/outputs)</b>	
Up to 30 m	Unshielded
Greater than 30 m	Shielded

<b>Analog output</b>	
External power supply	Max. 33 V
Current	0 .. 20 mA
Update time	1 s
Load	Max. 300 Ω
Resolution	10 Bit

<b>Terminal connection capacity (supply voltage)</b>	
Connectable conductors. Only one conductor can be connected per terminal.	
Single core, multi-core, fine-stranded	0.08 - 4.0 mm <sup>2</sup> , AWG 28-12
Terminal pins, core end sheath	0.2 - 2.5 mm <sup>2</sup>
Tightening torque	0.4 - 0.5 Nm
Stripping length	7 mm

<b>Terminal connection capacity (voltage measurement)</b>	
Connectable conductors. Only one conductor can be connected per terminal.	
Single core, multi-core, fine-stranded	0.08 - 4.0 mm <sup>2</sup> , AWG 28-12
Terminal pins, core end sheath	0.2 - 2.5 mm <sup>2</sup>
Tightening torque	0.4 - 0.5 Nm
Stripping length	7 mm

<b>Terminal connection capacity (current measurement)</b>	
Connectable conductors. Only one conductor can be connected per terminal.	
Single core, multi-core, fine-stranded	0.2 - 2.5 mm <sup>2</sup> , AWG 26-12
Terminal pins, core end sheath	0.2 - 2.5 mm <sup>2</sup>
Tightening torque	0.4 - 0.5 Nm
Stripping length	7 mm

<b>Terminal connection capacity (serial interface)</b>	
Single core, multi-core, fine-stranded	0.2 - 1.5 mm <sup>2</sup> , AWG 28-16
Terminal pins, core end sheath	0.2 - 1.5 mm <sup>2</sup>
Tightening torque	0.2 - 0.25 Nm
Stripping length	7 mm

<b>Terminal connection capacity (digital inputs and outputs, analog output)</b>	
Single core, multi-core, fine-stranded	0.2 - 1.5 mm <sup>2</sup> , AWG 28-16
Terminal pins, core end sheath	0.2 - 1.5 mm <sup>2</sup>
Tightening torque	0.2 - 0.25 Nm
Stripping length	7 mm

## FUNCTION PERFORMANCE CHARACTERISTICS

Function	Symbol	Precision class	Measurement range	Display range
Total active power	P	0.5 <sup>5)</sup> (IEC61557-12)	0 W .. 12.6 kW	0 W .. 999 GW *
Total reactive power	QA, Qv	1 (IEC61557-12)	0 var .. 16.6 kvar	0 var .. 999 Gvar *
Total apparent power	SA, Sv	0.5 <sup>5)</sup> (IEC61557-12)	0 VA .. 12.6 kVA	0 VA .. 999 GVA *
Total active energy	Ea	0.5 <sup>5)</sup> (IEC61557-12) 0.5S <sup>5)</sup> (IEC62053-22)	0 Wh .. 999 GWh	0 Wh .. 999 GWh *
Total reactive energy	ErA, ErV	1 (IEC61557-12)	0 varh .. 999 Gvarh	0 varh .. 999 Gvarh *
Total apparent energy	EapA, EapV	0.5 <sup>5)</sup> (IEC61557-12)	0 VAh .. 999 GVAh	0 VAh .. 999 GVAh *
Frequency	f	0.05 (IEC61557-12)	45 Hz .. 65 Hz	45,00 Hz .. 65,00 Hz
Phase current	I	0.2 (IEC61557-12)	0 A <sub>rms</sub> .. 7 A <sub>rms</sub>	0 A .. 999 kA
Neutral conductor current, calculated	INc	1.0 (IEC61557-12)	0.03 A .. 25 A	0,03 A .. 999 kA
Voltage	U L-N	0.2 (IEC61557-12)	10 V <sub>rms</sub> .. 600 V <sub>rms</sub>	0 V .. 999 kV
Voltage	U L-L	0.2 (IEC61557-12)	18 V <sub>rms</sub> .. 1040 V <sub>rms</sub>	0 V .. 999 kV
Power factor	PFA, PFV	0.5 (IEC61557-12)	0.00 .. 1.00	0,00 .. 1,00
Short-term flicker, long-term flicker	Pst, PIt	-	-	-
Voltage dips (L-N)	Udip	-	-	-
Voltage swells (L-N)	Uswl	-	-	-
Transient overvoltages	Utr	-	-	-
Voltage interruptions	Uint	-	-	-
Voltage symmetry (L-N) <sup>1)</sup>	Unba	-	-	-
Voltage symmetry (L-N) <sup>2)</sup>	Unb	-	-	-
Voltage harmonics	Uh	Kl. 1 (IEC61000-4-7)	1 .. 25 (odd)	0 V .. 999 kV
Voltage THD <sup>3)</sup>	THDu	1.0 (IEC61557-12)	0 % .. 999 %	0 % .. 999 %
Voltage THD <sup>4)</sup>	THD-Ru	-	-	-
Current harmonics	Ih	Kl. 1 (IEC61000-4-7)	1 .. 25 (odd)	0 A .. 999 kA
Current THD <sup>3)</sup>	THDi	1.0 (IEC61557-12)	0 % .. 999 %	0 % .. 999 %
Current THD <sup>4)</sup>	THD-Ri	-	-	-
Network signal voltage	MSV	-	-	-

1) In relation to the amplitude.

2) In relation to the phase and amplitude.

3) In relation to the power frequency.

4) In relation to the effective value.

5) Accuracy class 0.5/0.5S with ../5A transformer.  
Accuracy class 1 with ../1A transformer.

\* When the max. total energy value is reached, the display reverts back to 0 W.

Janitza electronics GmbH  
Vor dem Polstück 6  
35633 Lahnau, Germany  
Support Tel. +49 6441 9642-22  
Fax +49 6441 9642-30  
e-mail: [info@janitza.com](mailto:info@janitza.com)  
[www.janitza.com](http://www.janitza.com)

**Janitza**<sup>®</sup>